

Lly-507 in the Landscape of Epigenetic Modifiers: A Comparative Analysis

Author: BenchChem Technical Support Team. **Date:** April 2026

Compound of Interest

Compound Name: Lly-507
Cat. No.: B15584660

[Get Quote](#)

For Researchers, Scientists, and Drug Development Professionals

The field of epigenetics offers a promising frontier for therapeutic intervention, with histone methyltransferases emerging as a critical class of drug targets. **Lly-507**, a potent and selective inhibitor of SET and MYND domain-containing protein 2 (SMYD2), represents a significant tool for dissecting the roles of lysine methylation in health and disease. This guide provides a comparative analysis of **Lly-507** against other classes of epigenetic modifiers, including inhibitors of EZH2, PRMT5, and LSD1, supported by experimental data and detailed methodologies to aid in research and development decisions.

At a Glance: Lly-507 and Its standing

Lly-507 distinguishes itself as a highly potent and selective small molecule inhibitor of SMYD2, a protein-lysine methyltransferase implicated in the regulation of various cellular processes through the methylation of both histone and non-histone proteins.^{[1][2][3]} Its primary mechanism of action involves the inhibition of SMYD2's ability to methylate its substrates, such as the tumor suppressor p53.^{[1][4]} This targeted approach offers a distinct advantage over less specific therapeutic strategies.

Quantitative Comparison of Epigenetic Modifiers

The following tables summarize the in vitro efficacy (IC50 values) of **Lly-507** and other selected epigenetic modifiers across various cancer cell lines. It is important to note that direct comparisons should be made with caution, as experimental conditions can vary between studies.

Table 1: SMYD2 Inhibitors

Inhibitor	Target	Cell Line	IC50	Reference
Lly-507	SMYD2	p53 peptide assay	<15 nM	[1][3]
KYSE-150 (Esophageal)	0.6 µM (cellular p53 methylation)	[4]		
A549 (Lung)	2.13 µg/mL (48h), 0.71 µg/mL (72h)	[5]		
AZ505	SMYD2	Biochemical Assay	0.12 µM	[3][6]
BAY-598	SMYD2	Biochemical Assay	27 nM	[3]
A549 (Lung)	57.19 nM (24h), 24.12 nM (48h)	[7]		
H460 (Lung)	69.01 nM (24h), 31.72 nM (48h)	[7]		
A-893	SMYD2	Biochemical Assay	2.8 nM	[3]

Table 2: EZH2 Inhibitors

Inhibitor	Target	Cell Line	IC50	Reference
GSK126	EZH2	HEC-50B (Endometrial)	1.0 μ M	[8]
Ishikawa (Endometrial)	0.9 μ M	[8]		
EPZ-6438 (Tazemetostat)	EZH2	Various Lymphoma Lines	-	[9]
ZLD-1039	EZH2	Biochemical Assay	0.29 μ M	[10]
EI1	EZH2	Biochemical Assay (WT & Y641F)	15 nM & 13 nM	[11]

Table 3: PRMT5 Inhibitors

Inhibitor	Target	Cell Line	IC50	Reference
CMP5	PRMT5	HTLV-1 infected/ATL cell lines	3.98 - 23.94 μ M (120h)	[12]
HLCL61	PRMT5	ATL-related cell lines	3.09 - 7.58 μ M (120h)	[12]
Compound 17 (PPI inhibitor)	PRMT5:MEP50	LNCaP (Prostate)	430 nM (72h)	[13]
A549 (Lung)	447 nM	[13]		
C220	PRMT5	Ovarian/Breast Cancer Lines	3 - 18 nmol/L	[14]

Table 4: LSD1 Inhibitors

Inhibitor	Target	Cell Line	IC50	Reference
GSK2879552	LSD1	SCLC cell lines	-	
ORY-1001 (Iadademstat)	LSD1	AML cell lines	-	
SP-2577 (Secclidemstat)	LSD1	Ewing Sarcoma cell lines	-	

Signaling Pathways and Mechanisms of Action

The following diagrams illustrate the key signaling pathways modulated by **Lly-507** and other epigenetic modifiers.

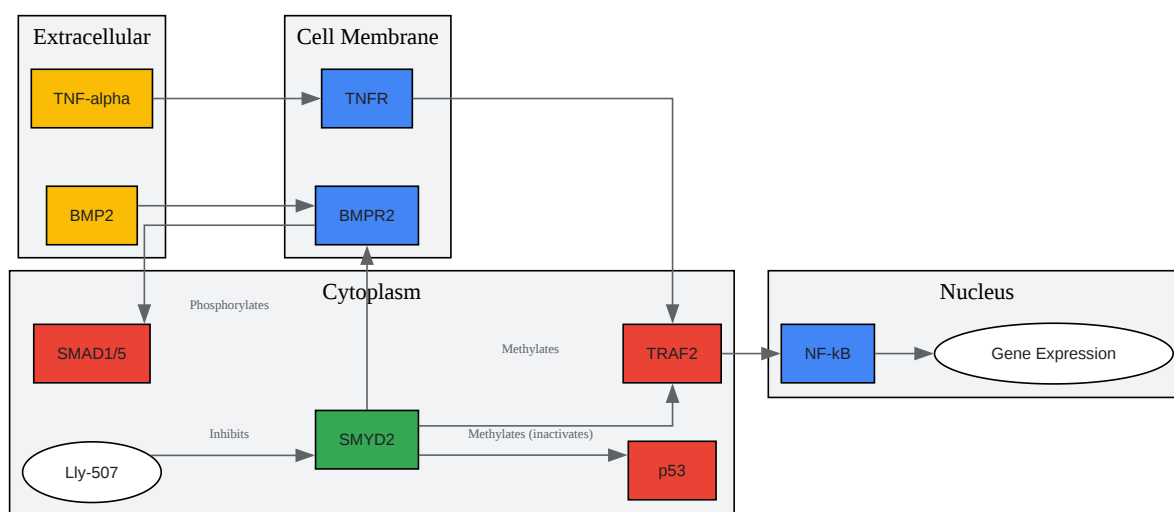

[Click to download full resolution via product page](#)

Caption: **Lly-507** inhibits SMYD2, impacting NF-κB and BMP signaling pathways.

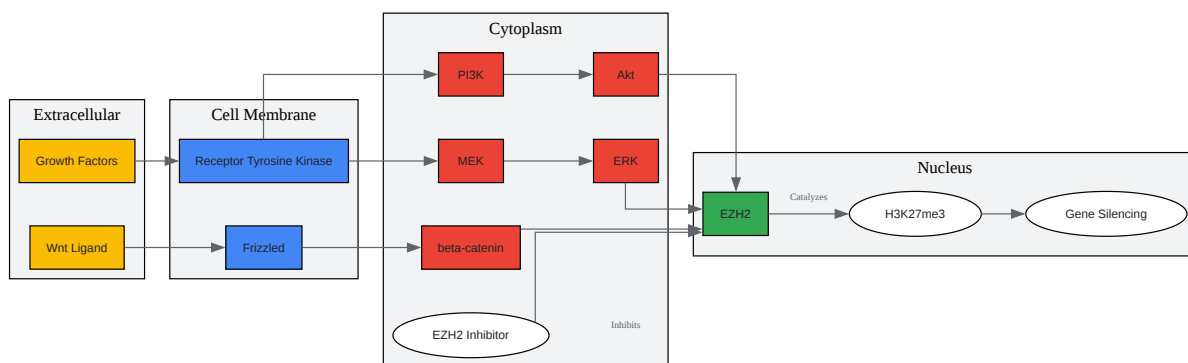

[Click to download full resolution via product page](#)

Caption: EZH2 inhibitors block H3K27 trimethylation, affecting key cancer pathways.

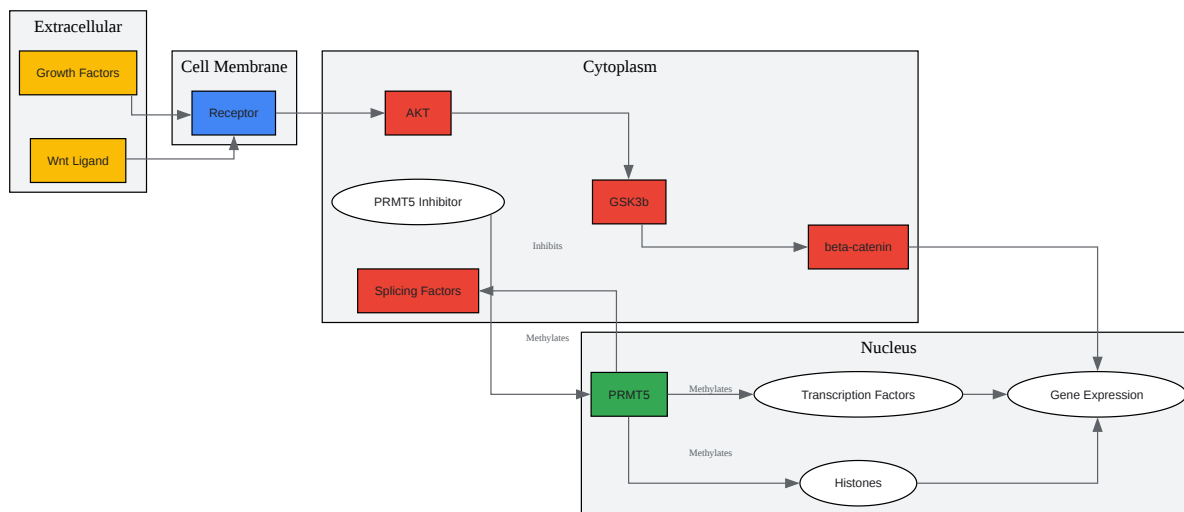

[Click to download full resolution via product page](#)

Caption: PRMT5 inhibitors disrupt methylation of histones and non-histone proteins.

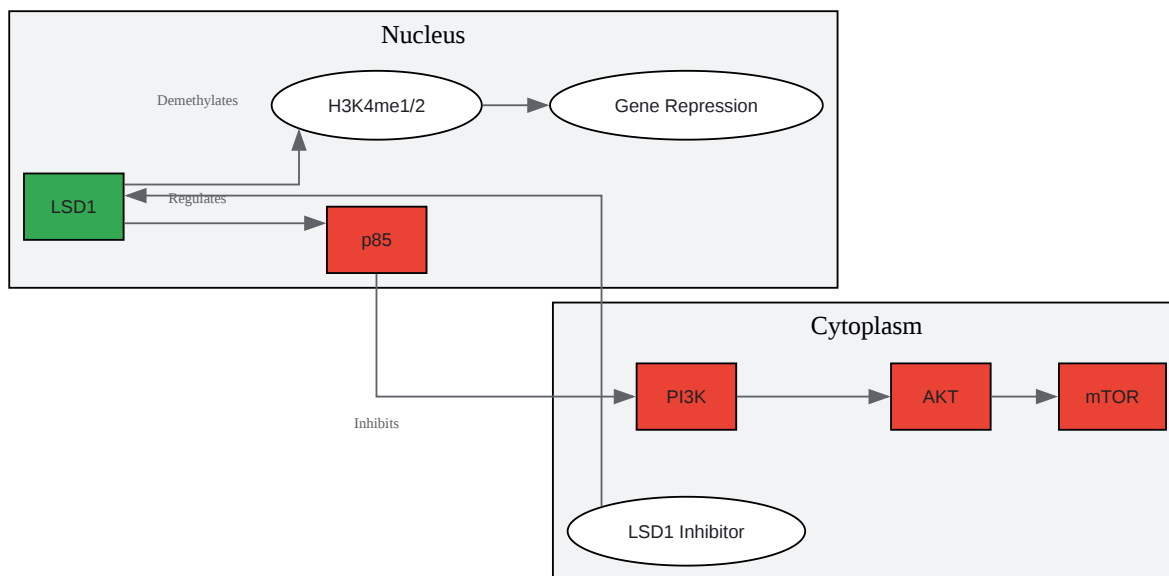

[Click to download full resolution via product page](#)

Caption: LSD1 inhibitors prevent demethylation of H3K4, impacting gene expression.

Experimental Protocols

Detailed methodologies for key experiments are provided below to ensure reproducibility and aid in the design of comparative studies.

In Vitro Histone Methyltransferase (HMT) Assay

This assay measures the enzymatic activity of a histone methyltransferase and the inhibitory potential of compounds like **Lly-507**.

Workflow:

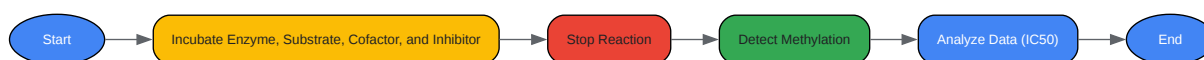

[Click to download full resolution via product page](#)

Caption: Workflow for a typical in vitro Histone Methyltransferase assay.

Materials:

- Recombinant histone methyltransferase (e.g., SMYD2, EZH2, PRMT5)
- Histone substrate (e.g., core histones, specific histone peptides)
- S-adenosyl-L-[methyl-3H]-methionine (radioactive cofactor) or S-adenosylmethionine (SAM) for non-radioactive assays
- Test inhibitor (e.g., **Lly-507**) at various concentrations
- Assay buffer (e.g., 50 mM Tris-HCl pH 8.5, 10 mM DTT, 10 mM MgCl₂)
- Scintillation fluid and counter (for radioactive assays) or specific detection reagents for non-radioactive assays (e.g., antibody-based detection)

Procedure:

- Prepare a reaction mixture containing the assay buffer, histone substrate, and the histone methyltransferase enzyme.
- Add the test inhibitor at a range of concentrations to the reaction mixture.
- Initiate the reaction by adding the cofactor (S-adenosyl-L-[methyl-3H]-methionine or SAM).
- Incubate the reaction at a specific temperature (e.g., 30°C) for a defined period (e.g., 60 minutes).
- Stop the reaction, typically by adding trichloroacetic acid or by spotting onto filter paper.
- For radioactive assays, wash the filter papers to remove unincorporated radiolabel, add scintillation fluid, and measure the incorporated radioactivity using a scintillation counter.

- For non-radioactive assays, detect the methylated product using methods such as ELISA with a methylation-specific antibody.
- Calculate the percentage of inhibition at each inhibitor concentration and determine the IC₅₀ value by fitting the data to a dose-response curve.

Cell Proliferation Assay (e.g., MTT or CellTiter-Glo®)

This assay determines the effect of an epigenetic modifier on the viability and proliferation of cancer cells.

Workflow:



[Click to download full resolution via product page](#)

Caption: General workflow for a cell proliferation assay.

Materials:

- Cancer cell line of interest
- Complete cell culture medium
- 96-well cell culture plates
- Test inhibitor (e.g., **Lly-507**) at various concentrations
- MTT reagent or CellTiter-Glo® Luminescent Cell Viability Assay kit
- Plate reader (spectrophotometer for MTT, luminometer for CellTiter-Glo®)

Procedure:

- Seed cells into a 96-well plate at a predetermined density and allow them to adhere overnight.

- Treat the cells with a serial dilution of the test inhibitor. Include a vehicle control (e.g., DMSO).
- Incubate the plates for a specified period (e.g., 48, 72, or 96 hours).
- For the MTT assay, add MTT reagent to each well and incubate for 2-4 hours to allow for formazan crystal formation. Solubilize the crystals with a solubilization buffer.
- For the CellTiter-Glo® assay, add the reagent directly to the wells to induce cell lysis and generate a luminescent signal proportional to the amount of ATP present.
- Measure the absorbance (MTT) or luminescence (CellTiter-Glo®) using a plate reader.
- Calculate the percentage of cell viability relative to the vehicle control and determine the IC50 value.

Western Blot Analysis of Histone Modifications

This technique is used to detect changes in specific histone methylation marks following treatment with an epigenetic modifier.

Workflow:



[Click to download full resolution via product page](#)

Caption: Step-by-step workflow for Western Blot analysis.

Materials:

- Cells treated with the test inhibitor
- Lysis buffer (e.g., RIPA buffer) with protease and phosphatase inhibitors
- Protein quantification assay kit (e.g., BCA assay)

- SDS-PAGE gels and electrophoresis apparatus
- Transfer membrane (e.g., PVDF or nitrocellulose) and transfer apparatus
- Blocking buffer (e.g., 5% non-fat milk or BSA in TBST)
- Primary antibody specific to the histone modification of interest (e.g., anti-H3K27me3) and a loading control (e.g., anti-Histone H3)
- HRP-conjugated secondary antibody
- Chemiluminescent substrate
- Imaging system

Procedure:

- Lyse the treated cells and extract total protein.
- Quantify the protein concentration of each sample.
- Separate the protein samples by size using SDS-PAGE.
- Transfer the separated proteins to a membrane.
- Block the membrane to prevent non-specific antibody binding.
- Incubate the membrane with the primary antibody overnight at 4°C.
- Wash the membrane and incubate with the HRP-conjugated secondary antibody.
- Add the chemiluminescent substrate and capture the signal using an imaging system.
- Analyze the band intensities to determine the relative change in the histone modification.

Conclusion

Lly-507 is a valuable research tool for investigating the biological functions of SMYD2. Its high potency and selectivity make it a strong candidate for further preclinical and clinical

development. This guide provides a framework for comparing **Lly-507** to other classes of epigenetic modifiers. The provided data and protocols are intended to assist researchers in designing and interpreting experiments aimed at elucidating the therapeutic potential of targeting histone methyltransferases in various diseases. As the field of epigenetics continues to evolve, comparative analyses such as this will be crucial for advancing novel therapeutic strategies.

Need Custom Synthesis?

BenchChem offers custom synthesis for rare earth carbides and specific isotopic labeling.

Email: info@benchchem.com or [Request Quote Online](#).

References

- [1. In Vitro Histone Methyltransferase Assay - PMC \[pmc.ncbi.nlm.nih.gov\]](#)
- [2. Histone Methyltransferase Assay in vitro \[en.bio-protocol.org\]](#)
- [3. medchemexpress.com \[medchemexpress.com\]](#)
- [4. LLY-507, a Cell-active, Potent, and Selective Inhibitor of Protein-lysine Methyltransferase SMYD2 - PMC \[pmc.ncbi.nlm.nih.gov\]](#)
- [5. Dissecting the Role of SMYD2 and Its Inhibitor \(LLY-507\) in the Treatment of Chemically Induced Non-Small Cell Lung Cancer \(NSCLC\) by Using Fe₃O₄ Nanoparticles Drug Delivery System - PMC \[pmc.ncbi.nlm.nih.gov\]](#)
- [6. selleckchem.com \[selleckchem.com\]](#)
- [7. Synergistic anticancer effects of SMYD2 inhibitor BAY-598 and doxorubicin in non-small cell lung cancer - PMC \[pmc.ncbi.nlm.nih.gov\]](#)
- [8. researchgate.net \[researchgate.net\]](#)
- [9. Inhibition of EZH2 transactivation function sensitizes solid tumors to genotoxic stress - PMC \[pmc.ncbi.nlm.nih.gov\]](#)
- [10. | BioWorld \[bioworld.com\]](#)
- [11. pnas.org \[pnas.org\]](#)
- [12. Inhibition of PRMT5/MEP50 Arginine Methyltransferase Activity Causes Cancer Vulnerability in NDRG2^{low} Adult T-Cell Leukemia/Lymphoma - PMC \[pmc.ncbi.nlm.nih.gov\]](#)

- [13. Discovery and biological characterization of PRMT5:MEP50 protein:protein interaction inhibitors - PMC \[pmc.ncbi.nlm.nih.gov\]](#)
- [14. aacrjournals.org \[aacrjournals.org\]](#)
- To cite this document: BenchChem. [Lly-507 in the Landscape of Epigenetic Modifiers: A Comparative Analysis]. BenchChem, [2026]. [Online PDF]. Available at: [\[https://www.benchchem.com/product/b15584660/docs#lly-507-in-the-landscape-of-epigenetic-modifiers-a-comparative-analysis\]](https://www.benchchem.com/product/b15584660/docs#lly-507-in-the-landscape-of-epigenetic-modifiers-a-comparative-analysis)

Disclaimer & Data Validity:

The information provided in this document is for Research Use Only (RUO) and is strictly not intended for diagnostic or therapeutic procedures. While BenchChem strives to provide accurate protocols, we make no warranties, express or implied, regarding the fitness of this product for every specific experimental setup.

Technical Support: The protocols provided are for reference purposes. Unsure if this reagent suits your experiment?

Need Industrial/Bulk Grade? [Request Custom Synthesis Quote](#)

BenchChem

Our mission is to be the trusted global source of essential and advanced chemicals, empowering scientists and researchers to drive progress in science and industry.

Contact

Address: 3281 E Guasti Rd
Ontario, CA 91761, United States
Phone: (601) 213-4426
Email: info@benchchem.com

[Contact our Ph.D. Support Team for a compatibility check](#)

