

JNJ-7706621: An In-Depth Technical Guide to its Target Selectivity Profile

Author: BenchChem Technical Support Team. **Date:** April 2026

Compound of Interest

Compound Name: JNJ-9350
Cat. No.: B15584637

[Get Quote](#)

For Researchers, Scientists, and Drug Development Professionals

Core Tenet: Dual Inhibition of Cyclin-Dependent Kinases and Aurora Kinases

JNJ-7706621 is a potent small molecule inhibitor that targets key regulators of the cell cycle, demonstrating significant therapeutic potential in oncology.^{[1][2]} Its primary mechanism of action is the dual inhibition of two critical families of serine/threonine kinases: the Cyclin-Dependent Kinases (CDKs) and the Aurora Kinases.^{[1][2][3]} This dual activity disrupts cell cycle progression at multiple checkpoints, leading to cell growth inhibition, apoptosis, and endoreduplication in cancer cells.^{[1][4]}

Quantitative Analysis of Kinase Inhibition

The inhibitory activity of JNJ-7706621 has been quantified against a range of kinases, revealing a potent and relatively selective profile. The half-maximal inhibitory concentrations (IC50) for its primary targets are in the low nanomolar range, indicating high potency.

Primary Target Inhibition

Target	IC50 (nM)
CDK1/Cyclin B	9
CDK2/Cyclin A	4
CDK2/Cyclin E	3
Aurora A	11
Aurora B	15

Data sourced from multiple studies.[3][5]

Selectivity Against Other Kinases

JNJ-7706621 has been profiled against a broad panel of kinases to determine its selectivity. While it is a pan-CDK inhibitor, it shows significantly higher potency for CDK1 and CDK2 over other family members.[5] Notably, it has been reported to have no significant activity against Plk1 and Wee1 kinases at the highest concentrations tested.[3][5] The compound also exhibits inhibitory activity against other kinases, albeit at higher concentrations.

Target	IC50 (nM)
CDK3	>58
CDK4	>58
CDK6	>58
VEGF-R2	154-254
FGF-R2	154-254
GSK3 β	154-254

Data reflects a compilation from available research.[5][6]

A comprehensive kinome-wide affinity profile for JNJ-7706621 is available through large-scale screening platforms such as DiscoverX KINOMEScan®, EMD Millipore KinaseProfiler™, and

Reaction Biology HotSpot™.[7][8] These screens provide a broader understanding of the compound's selectivity across the human kinome.

Cellular Activity

In cellular assays, JNJ-7706621 demonstrates potent anti-proliferative effects across a variety of human cancer cell lines, with IC50 values typically in the range of 112 to 514 nM.[3][5] This activity is largely independent of the p53 or retinoblastoma (Rb) status of the cancer cells.[1][4] In contrast, the compound is significantly less potent against normal human cell lines, with IC50 values in the micromolar range, suggesting a therapeutic window.[5]

Cell Line	Cancer Type	IC50 (nM)
HeLa	Cervical Cancer	284
HCT116	Colon Carcinoma	254
A375	Melanoma	447
PC3	Prostate Adenocarcinoma	120

IC50 values are representative
and may vary between studies.

[3][5]

Signaling Pathways and Experimental Workflows

The dual inhibition of CDKs and Aurora kinases by JNJ-7706621 impacts critical cell cycle and apoptotic pathways.

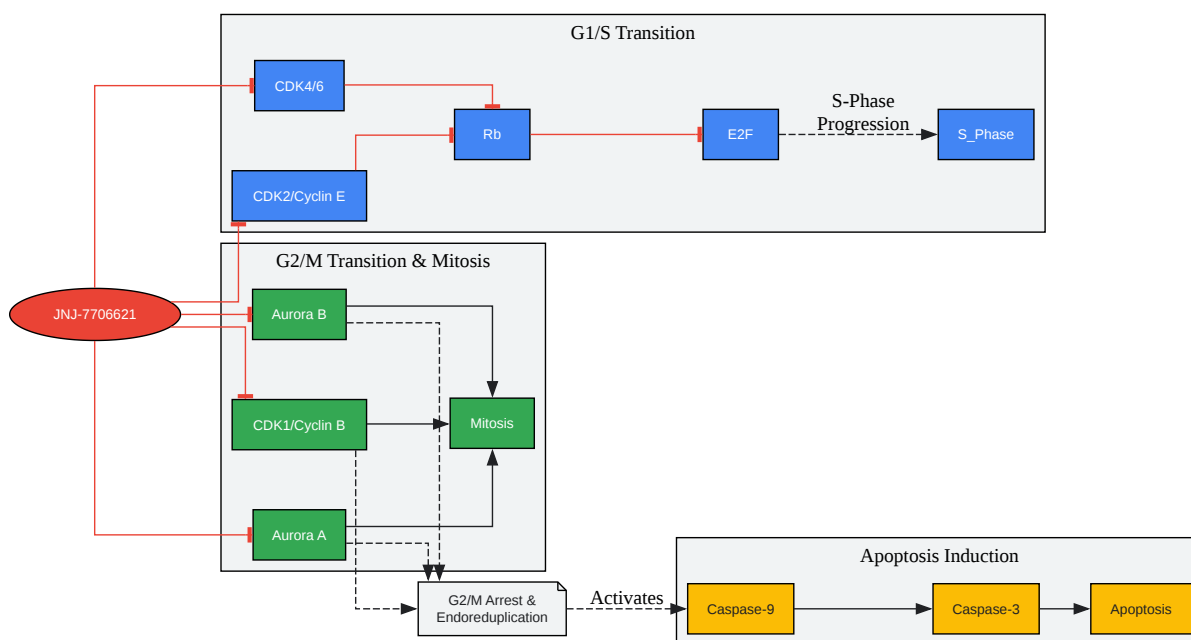

[Click to download full resolution via product page](#)

Caption: JNJ-7706621 inhibits CDKs and Aurora kinases, leading to cell cycle arrest and apoptosis.

Experimental Protocols

In Vitro Kinase Inhibition Assay (Radiometric)

This protocol outlines a radiometric method to determine the inhibitory activity of JNJ-7706621 against specific kinases.

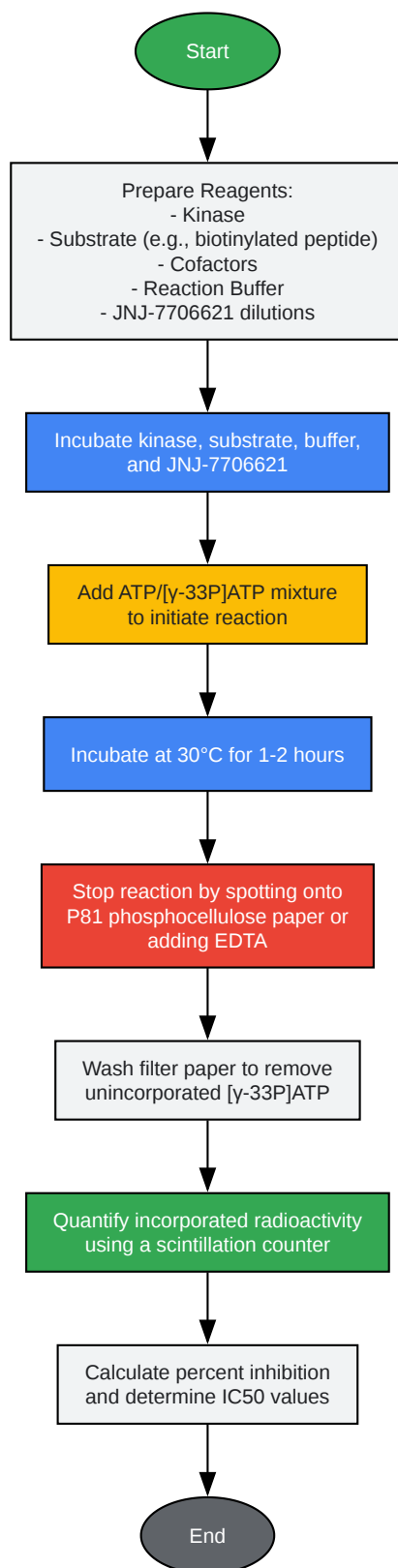

[Click to download full resolution via product page](#)

Caption: Workflow for a radiometric in vitro kinase inhibition assay.

Detailed Steps:

- Reagent Preparation:
 - Dilute the target kinase (e.g., CDK1/cyclin B) in a reaction buffer (e.g., 20 mM HEPES pH 7.5, 10 mM MgCl₂, 1 mM EGTA, 0.02% Brij35, 0.1 mM Na₃VO₄, 2 mM DTT).[9]
 - Prepare a solution of the specific substrate peptide.[9]
 - Prepare serial dilutions of JNJ-7706621 in DMSO.
- Reaction Setup:
 - In a 96-well plate, combine the kinase, substrate, and reaction buffer.
 - Add the diluted JNJ-7706621 or DMSO (vehicle control) to the wells.
 - Allow a brief pre-incubation period (e.g., 20 minutes at room temperature).[9]
- Initiation and Incubation:
 - Initiate the kinase reaction by adding a mixture of ATP and [γ -³³P]ATP (final concentration typically 10 μ M).[9]
 - Incubate the plate at 30°C for 1 to 2 hours.[5]
- Termination and Detection:
 - Stop the reaction by spotting the reaction mixture onto P81 phosphocellulose filter paper.[9]
 - Wash the filter paper extensively with 0.75% phosphoric acid to remove unincorporated [γ -³³P]ATP.[9]
 - Measure the amount of incorporated ³³P in the substrate using a scintillation counter.[5]
- Data Analysis:

- Calculate the percentage of kinase activity remaining in the presence of the inhibitor compared to the vehicle control.
- Determine the IC50 value by fitting the dose-response data to a suitable model.

Cell Proliferation Assay ([¹⁴C]-Thymidine Incorporation)

This assay measures the effect of JNJ-7706621 on the proliferation of cancer cells by quantifying the incorporation of radiolabeled thymidine into newly synthesized DNA.[5]

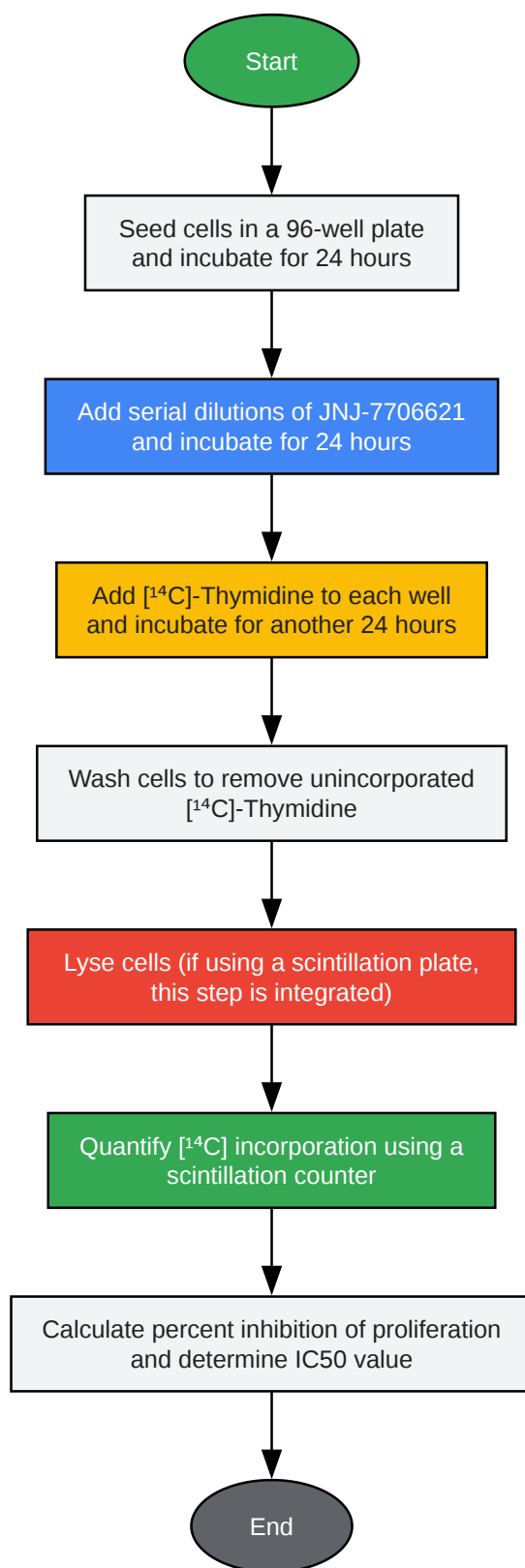

[Click to download full resolution via product page](#)

Caption: Workflow for a $[^{14}\text{C}]$ -Thymidine incorporation cell proliferation assay.

Detailed Steps:

- Cell Seeding:
 - Trypsinize and count the desired cancer cell line.
 - Seed the cells into a 96-well plate at a predetermined density (e.g., 3,000-8,000 cells/well) and incubate for 24 hours.[\[5\]](#)
- Compound Treatment:
 - Prepare serial dilutions of JNJ-7706621 in the appropriate cell culture medium.
 - Add the diluted compound to the wells and incubate for 24 hours.[\[5\]](#)
- Radiolabeling:
 - Add [¹⁴C]-methyl-thymidine to each well at a final concentration of approximately 0.2 μCi/well.[\[5\]](#)
 - Incubate the plate for an additional 24 hours.[\[5\]](#)
- Harvesting and Detection:
 - Aspirate the medium and wash the cells twice with PBS.[\[5\]](#)
 - If using a standard plate, lyse the cells and transfer the lysate to a scintillation vial.
 - If using a scintillating microplate (e.g., CytoStar), the incorporated radioactivity can be measured directly.[\[5\]](#)
- Data Analysis:
 - Quantify the amount of [¹⁴C]-thymidine incorporation using a scintillation counter.
 - Calculate the percentage of inhibition of cell proliferation relative to the vehicle-treated control cells.
 - Determine the IC50 value from the dose-response curve.

Conclusion

JNJ-7706621 is a potent dual inhibitor of CDKs and Aurora kinases with a well-defined target selectivity profile. Its ability to induce cell cycle arrest and apoptosis in a broad range of cancer cell lines at nanomolar concentrations, while showing reduced activity against normal cells, underscores its potential as a therapeutic agent. The provided experimental protocols offer a foundation for further investigation and characterization of this and similar compounds in drug discovery and development.

Need Custom Synthesis?

BenchChem offers custom synthesis for rare earth carbides and specific isotopic labeling.

Email: info@benchchem.com or [Request Quote Online](#).

References

- [1. The in vitro and in vivo effects of JNJ-7706621: a dual inhibitor of cyclin-dependent kinases and aurora kinases - PubMed \[pubmed.ncbi.nlm.nih.gov\]](#)
- [2. researchgate.net \[researchgate.net\]](#)
- [3. medchemexpress.com \[medchemexpress.com\]](#)
- [4. researchgate.net \[researchgate.net\]](#)
- [5. selleckchem.com \[selleckchem.com\]](#)
- [6. JNJ-7706621 | CDK | Apoptosis | Aurora Kinase | TargetMol \[targetmol.com\]](#)
- [7. JNJ-7706621 | Ligand page | IUPHAR/BPS Guide to PHARMACOLOGY \[guidetopharmacology.org\]](#)
- [8. guidetopharmacology.org \[guidetopharmacology.org\]](#)
- [9. Comprehensive assay of kinase catalytic activity reveals features of kinase inhibitor selectivity - PMC \[pmc.ncbi.nlm.nih.gov\]](#)
- To cite this document: BenchChem. [JNJ-7706621: An In-Depth Technical Guide to its Target Selectivity Profile]. BenchChem, [2026]. [Online PDF]. Available at: [\[https://www.benchchem.com/product/b15584637/docs#jnj-7706621-an-in-depth-technical-guide-to-its-target-selectivity-profile\]](https://www.benchchem.com/product/b15584637/docs#jnj-7706621-an-in-depth-technical-guide-to-its-target-selectivity-profile)

Disclaimer & Data Validity:

The information provided in this document is for Research Use Only (RUO) and is strictly not intended for diagnostic or therapeutic procedures. While BenchChem strives to provide accurate protocols, we make no warranties, express or implied, regarding the fitness of this product for every specific experimental setup.

Technical Support: The protocols provided are for reference purposes. Unsure if this reagent suits your experiment?

Need Industrial/Bulk Grade? [Request Custom Synthesis Quote](#)

BenchChem

Our mission is to be the trusted global source of essential and advanced chemicals, empowering scientists and researchers to drive progress in science and industry.

Contact

Address: 3281 E Guasti Rd
Ontario, CA 91761, United States
Phone: (601) 213-4426
Email: info@benchchem.com

[Contact our Ph.D. Support Team for a compatibility check](#)