

How to control for vehicle effects when using GSK3335103

Author: BenchChem Technical Support Team. **Date:** April 2026

Compound of Interest

Compound Name: GSK3335103

Cat. No.: B15584887

[Get Quote](#)

Technical Support Center: GSK3335103

This technical support center provides troubleshooting guides and frequently asked questions (FAQs) for researchers, scientists, and drug development professionals using **GSK3335103**. The information is designed to address specific issues that may be encountered during experiments and to provide guidance on best practices for vehicle control.

Frequently Asked Questions (FAQs)

Q1: What is **GSK3335103** and what is its mechanism of action?

GSK3335103 is an orally active, small-molecule, RGD-mimetic inhibitor of the $\alpha\beta6$ integrin.[1][2][3] The $\alpha\beta6$ integrin plays a crucial role in the activation of transforming growth factor- β (TGF- β), a key pro-fibrotic cytokine.[1][2][4] By inhibiting $\alpha\beta6$, **GSK3335103** attenuates TGF- β signaling, which has been shown to reduce collagen deposition in preclinical models of fibrosis.[1][2] The mechanism involves the induction of concentration- and time-dependent internalization of the $\alpha\beta6$ integrin, followed by its lysosomal degradation.[1][2]

Q2: What is a vehicle control and why is it essential when using **GSK3335103**?

A vehicle control is a formulation containing all the components of the drug treatment solution except for the active pharmaceutical ingredient, in this case, **GSK3335103**. It is administered to a control group of cells or animals in the same manner and volume as the drug treatment.

Using a vehicle control is critical to differentiate the biological effects of **GSK3335103** from any potential effects of the solvent or other excipients used to deliver the compound.

Q3: What is the recommended vehicle for in vitro studies with **GSK3335103**?

GSK3335103 has a reported solubility of 10 mM in dimethyl sulfoxide (DMSO). Therefore, DMSO is a suitable solvent for preparing a concentrated stock solution for in vitro experiments. For cell-based assays, this stock solution should be serially diluted in cell culture medium to the final desired concentration. It is crucial to ensure the final concentration of DMSO in the culture medium is low (typically $\leq 0.5\%$) to avoid solvent-induced cytotoxicity. A vehicle control group treated with the same final concentration of DMSO is essential.

Q4: What is a potential vehicle for in vivo oral administration of **GSK3335103**?

While a specific, publicly validated vehicle for oral administration of **GSK3335103** in rodents is not readily available, a formulation used for a similar oral, selective $\alpha v \beta 6$ integrin inhibitor (MORF-627) in non-human primates was 0.5% HPMC E4M (hydroxypropyl methylcellulose) in Nanopure water (w/v). This type of aqueous suspension is a common choice for oral gavage of small molecules with poor aqueous solubility. Researchers should consider this as a starting point and perform their own formulation development and tolerability studies for their specific animal model.

Troubleshooting Guides

In Vitro Experiments

Issue: Precipitation of **GSK3335103** in cell culture medium.

- Possible Cause: The final concentration of **GSK3335103** exceeds its solubility in the aqueous environment of the cell culture medium, even with a small percentage of DMSO.
- Troubleshooting Steps:

- **Reduce Final Concentration:** Determine the lowest effective concentration of **GSK3335103** in your assay to minimize the amount of compound needed.
- **Optimize Dilution Method:** Instead of a single large dilution, perform a stepwise serial dilution of the DMSO stock into pre-warmed (37°C) culture medium while gently vortexing. This can prevent localized high concentrations that are prone to precipitation.
- **Serum Content:** The presence of serum in the culture medium can sometimes help to solubilize hydrophobic compounds. If your experiment allows, ensure serum is present in the medium during dilution.
- **Solubility Test:** Perform a small-scale solubility test by preparing serial dilutions of **GSK3335103** in your complete cell culture medium and visually inspecting for precipitation after incubation at 37°C for a few hours.

In Vivo Experiments

Issue: Inconsistent results or signs of toxicity in vehicle-treated animals.

- **Possible Cause:** The chosen vehicle formulation may have unexpected biological effects or may not be well-tolerated by the animal model at the administered volume or frequency.
- **Troubleshooting Steps:**
 - **Vehicle Tolerability Study:** Before initiating a large-scale efficacy study, conduct a pilot study with a small group of animals to assess the tolerability of the vehicle alone. Monitor for any adverse effects such as weight loss, changes in behavior, or signs of gastrointestinal distress.
 - **Optimize Vehicle Components:** If the initial vehicle is not well-tolerated, consider alternative formulations. For aqueous suspensions, varying the concentration or type of suspending agent (e.g., carboxymethylcellulose) may improve tolerability.
 - **Dosing Volume and Frequency:** Ensure that the dosing volume is within the recommended limits for the species and route of administration (e.g., for oral gavage in mice, typically 5-10 mL/kg). If multiple doses are required, assess the cumulative effect of the vehicle.

- Fresh Preparation: Prepare the vehicle formulation fresh before each use, especially if it is a suspension, to ensure homogeneity and prevent degradation of components.

Data Presentation

Table 1: Solubility of **GSK3335103**

Solvent	Solubility	Source
DMSO (Dimethyl Sulfoxide)	10 mM	--INVALID-LINK--

Table 2: Potential In Vivo Vehicle Formulation for Oral Administration

Vehicle Component	Concentration	Notes
Hydroxypropyl Methylcellulose (HPMC E4M)	0.5% (w/v)	Based on a formulation for a similar $\alpha\beta6$ inhibitor. Requires validation.
Nanopure Water	To final volume	Ensure sterility for administration.

Experimental Protocols

Protocol 1: Preparation of **GSK3335103** for In Vitro Cell-Based Assays

- Prepare Stock Solution: Dissolve **GSK3335103** in 100% DMSO to a stock concentration of 10 mM. Ensure complete dissolution by vortexing. Store aliquots at -20°C or -80°C to avoid repeated freeze-thaw cycles.
- Prepare Intermediate Dilutions: On the day of the experiment, thaw a stock aliquot and prepare serial dilutions in 100% DMSO if a wide range of concentrations is to be tested.
- Prepare Final Working Solutions: Pre-warm complete cell culture medium to 37°C . Add a small volume of the DMSO stock or intermediate dilution to the medium to achieve the final desired concentration of **GSK3335103**. The final DMSO concentration should be kept constant across all treatments and the vehicle control (ideally $\leq 0.5\%$). For example, to

achieve a 10 μM final concentration from a 10 mM stock, you can add 1 μL of the stock to 1 mL of medium (resulting in a final DMSO concentration of 0.1%).

- Vehicle Control: Prepare a vehicle control by adding the same volume of 100% DMSO to the cell culture medium as used for the highest concentration of **GSK3335103**.
- Treatment: Replace the existing medium in the cell culture plates with the medium containing the final concentrations of **GSK3335103** or the vehicle control.

Protocol 2: Suggested Starting Protocol for In Vivo Oral Administration in Mice

- Vehicle Preparation (0.5% HPMC):
 - Weigh the required amount of HPMC E4M powder.
 - In a sterile container, slowly add the HPMC powder to sterile Nanopure water while stirring continuously to avoid clumping.
 - Continue stirring until a homogenous suspension is formed. This may take some time.
- **GSK3335103** Formulation:
 - Weigh the required amount of **GSK3335103** powder to achieve the desired final dosing concentration (e.g., mg/kg).
 - Triturate the **GSK3335103** powder with a small amount of the prepared vehicle to form a paste.
 - Gradually add the remaining vehicle while continuously mixing to ensure a uniform suspension.
- Vehicle Control: The 0.5% HPMC in water solution serves as the vehicle control.
- Administration (Oral Gavage):
 - Before each dosing session, ensure the **GSK3335103** formulation is thoroughly mixed to resuspend the compound.

- Administer the formulation or the vehicle control to the respective groups of mice using a proper-sized oral gavage needle. The volume should be based on the individual animal's body weight (e.g., 10 mL/kg).

Mandatory Visualization

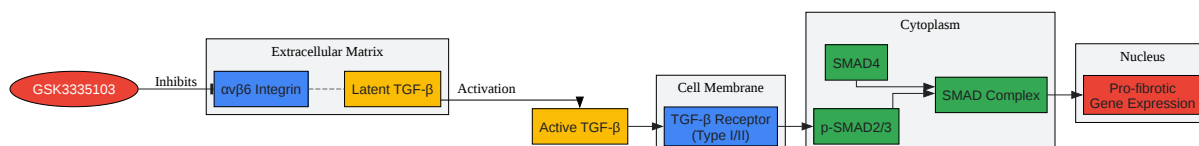

[Click to download full resolution via product page](#)

Caption: TGF- β signaling pathway and the inhibitory action of **GSK3335103**.

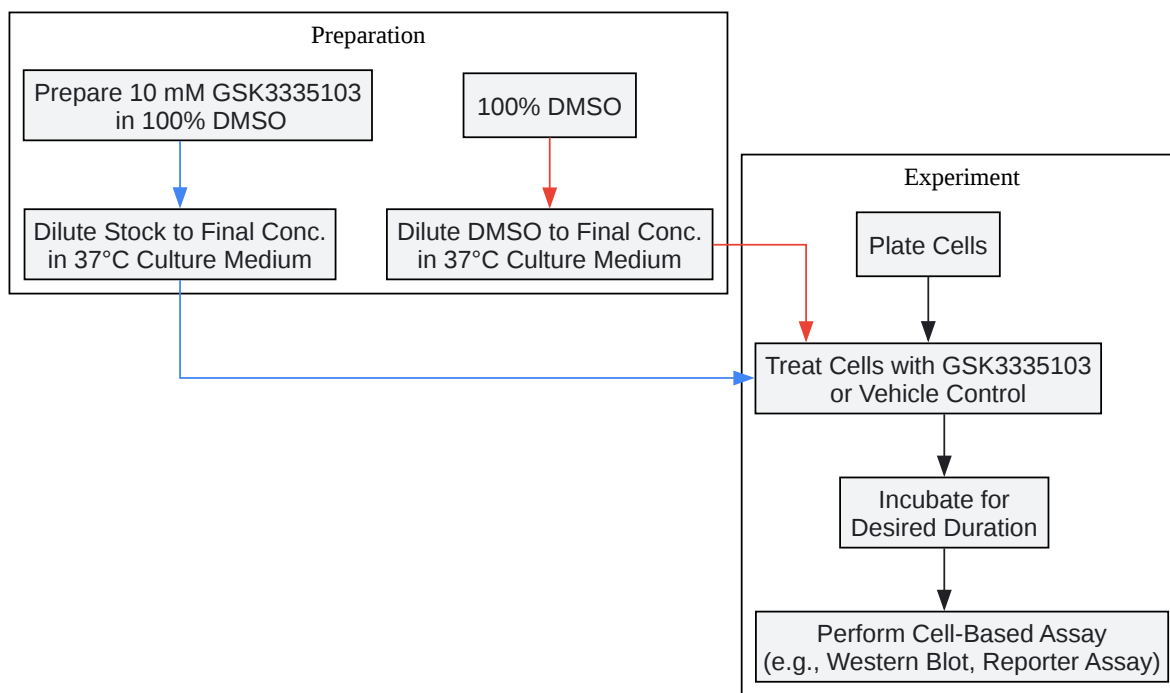

[Click to download full resolution via product page](#)

Caption: Experimental workflow for in vitro studies with **GSK3335103**.

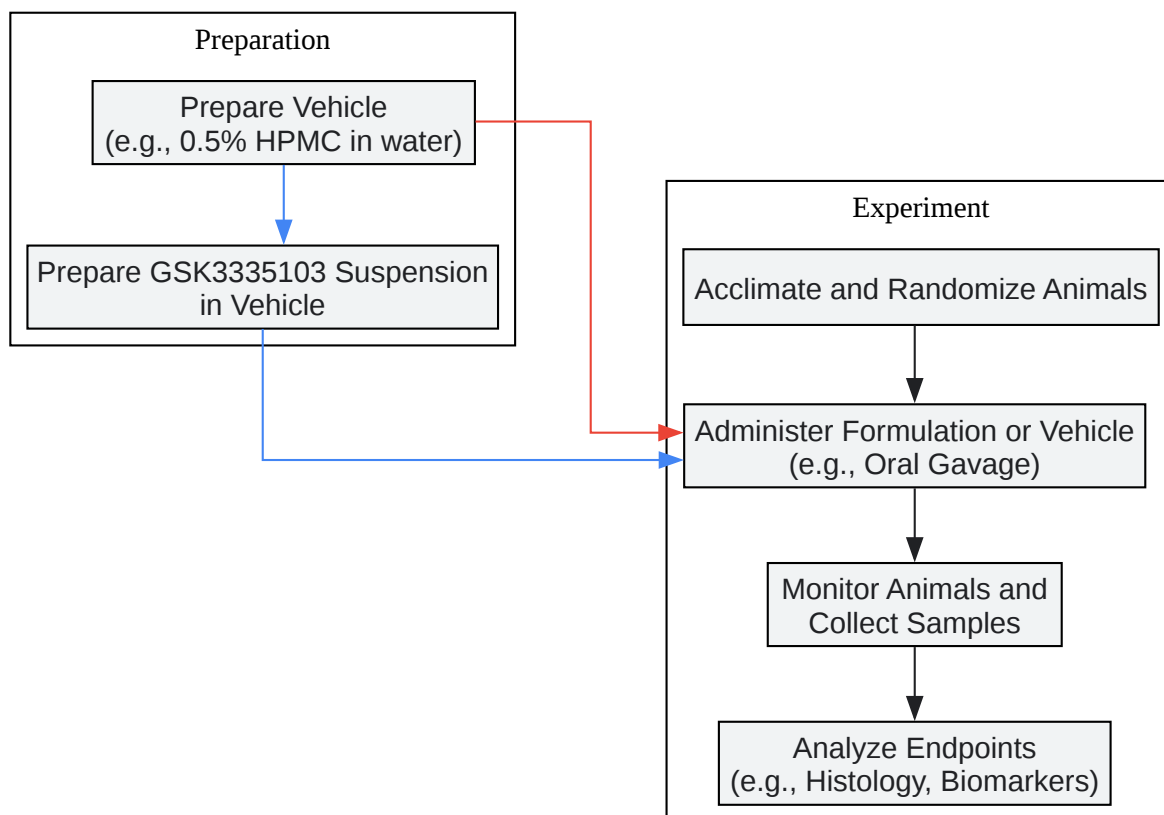

[Click to download full resolution via product page](#)

Caption: General experimental workflow for in vivo studies with **GSK3335103**.

Need Custom Synthesis?

BenchChem offers custom synthesis for rare earth carbides and specific isotopic labeling.

Email: info@benchchem.com or [Request Quote Online](#).

References

- 1. Pharmacological characterisation of GSK3335103, an oral $\alpha\text{v}\beta\text{6}$ integrin small molecule RGD-mimetic inhibitor for the treatment of fibrotic disease - PubMed

[\[pubmed.ncbi.nlm.nih.gov\]](https://pubmed.ncbi.nlm.nih.gov)

- [2. researchgate.net \[researchgate.net\]](https://researchgate.net)
- [3. medchemexpress.com \[medchemexpress.com\]](https://medchemexpress.com)
- [4. mdpi.com \[mdpi.com\]](https://mdpi.com)
- To cite this document: BenchChem. [How to control for vehicle effects when using GSK3335103]. BenchChem, [2026]. [Online PDF]. Available at: [\[https://www.benchchem.com/product/b15584887/docs#how-to-control-for-vehicle-effects-when-using-gsk3335103\]](https://www.benchchem.com/product/b15584887/docs#how-to-control-for-vehicle-effects-when-using-gsk3335103)

Disclaimer & Data Validity:

The information provided in this document is for Research Use Only (RUO) and is strictly not intended for diagnostic or therapeutic procedures. While BenchChem strives to provide accurate protocols, we make no warranties, express or implied, regarding the fitness of this product for every specific experimental setup.

Technical Support: The protocols provided are for reference purposes. Unsure if this reagent suits your experiment?

Need Industrial/Bulk Grade? [Request Custom Synthesis Quote](#)

BenchChem

Our mission is to be the trusted global source of essential and advanced chemicals, empowering scientists and researchers to drive progress in science and industry.

Contact

Address: 3281 E Guasti Rd
Ontario, CA 91761, United States
Phone: (601) 213-4426
Email: info@benchchem.com

[Contact our Ph.D. Support Team for a compatibility check](#)

