

# Ebio3 Application in Brain Slice Electrophysiology: Application Notes and Protocols

**Author:** BenchChem Technical Support Team. **Date:** December 2025

## Compound of Interest

Compound Name: *Ebio3*

Cat. No.: *B15584473*

[Get Quote](#)

For Researchers, Scientists, and Drug Development Professionals

## Introduction

The term "**Ebio3**" has emerged in neuroscience research in two distinct contexts, which is critical to differentiate for experimental design and data interpretation. The first refers to the **Ebio3** (Epstein-Barr virus-induced gene 3) protein, a subunit of the heterodimeric cytokine Interleukin-27 (IL-27). The second is a recently identified small molecule, **Ebio3**, which acts as a potent and selective inhibitor of the KCNQ2 potassium channel. This document provides detailed application notes and protocols for the use of both of these "**Ebio3**" entities in the context of brain slice electrophysiology.

## Part 1: The Cytokine Subunit Ebio3 (as part of Interleukin-27)

### Application Note

The **Ebio3** protein, in conjunction with the p28 subunit, forms the cytokine IL-27.[1] Within the central nervous system (CNS), IL-27 is recognized for its significant neuroprotective and anti-inflammatory properties.[2][3] It is produced by various cells, including astrocytes and microglia, particularly in response to inflammation and neuronal damage.[4] IL-27 exerts its effects by

binding to a receptor complex composed of IL-27R $\alpha$  and gp130, which subsequently activates the JAK/STAT signaling pathway, primarily involving STAT1 and STAT3.[5]

In the context of brain slice electrophysiology, recombinant IL-27 can be utilized to investigate its modulatory effects on neuronal function, synaptic plasticity, and neuroinflammatory processes in an ex vivo setting. Researchers can apply IL-27 to acute brain slices from various regions (e.g., hippocampus, cortex) of wild-type or disease model animals to explore its potential therapeutic effects. While direct, quantitative electrophysiological data on the effects of IL-27 on neuronal firing and synaptic plasticity in brain slices is still emerging, its known signaling pathway and neuroprotective roles suggest it as a valuable tool for studying the interplay between the immune system and neuronal excitability.

## Signaling Pathway

The binding of IL-27 to its receptor complex initiates a phosphorylation cascade, leading to the activation of STAT1 and STAT3. These transcription factors then translocate to the nucleus to regulate the expression of target genes involved in inflammation and cell survival.

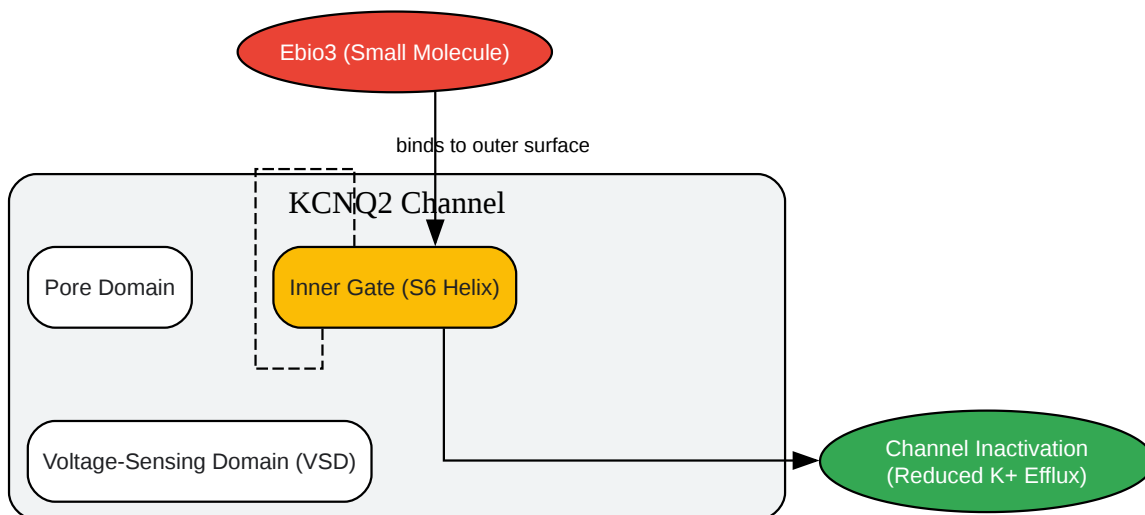
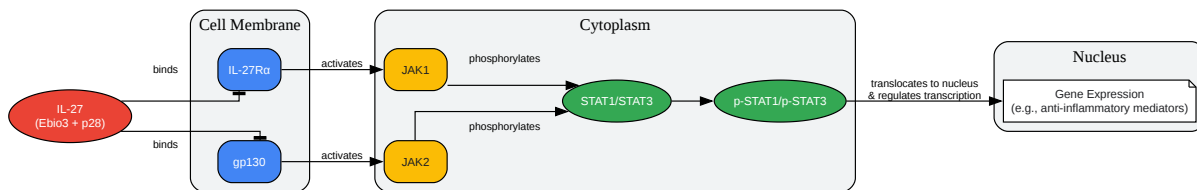

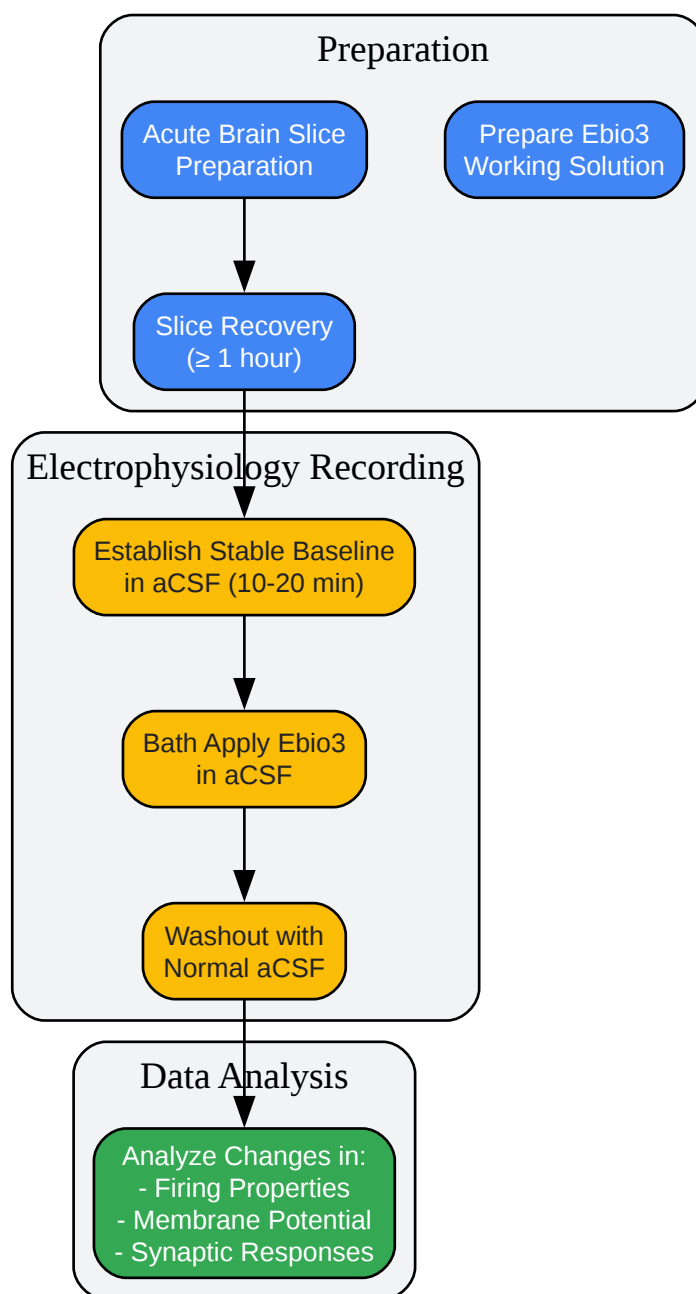

[Click to download full resolution via product page](#)

### Need Custom Synthesis?

BenchChem offers custom synthesis for rare earth carbides and specific isotopic labeling.

Email: [info@benchchem.com](mailto:info@benchchem.com) or [Request Quote Online](#).

## References

- 1. pmc.ncbi.nlm.nih.gov [pmc.ncbi.nlm.nih.gov]
- 2. pmc.ncbi.nlm.nih.gov [pmc.ncbi.nlm.nih.gov]
- 3. Research Portal [scholarship.miami.edu]
- 4. pmc.ncbi.nlm.nih.gov [pmc.ncbi.nlm.nih.gov]
- 5. Structure of the IL-27 quaternary receptor signaling complex | eLife [elifesciences.org]
- To cite this document: BenchChem. [Ebio3 Application in Brain Slice Electrophysiology: Application Notes and Protocols]. BenchChem, [2025]. [Online PDF]. Available at: [https://www.benchchem.com/product/b15584473#ebio3-application-in-brain-slice-electrophysiology]

---

### Disclaimer & Data Validity:

The information provided in this document is for Research Use Only (RUO) and is strictly not intended for diagnostic or therapeutic procedures. While BenchChem strives to provide accurate protocols, we make no warranties, express or implied, regarding the fitness of this product for every specific experimental setup.

**Technical Support:** The protocols provided are for reference purposes. Unsure if this reagent suits your experiment? [[Contact our Ph.D. Support Team for a compatibility check](#)]

**Need Industrial/Bulk Grade?** [Request Custom Synthesis Quote](#)

## BenchChem

Our mission is to be the trusted global source of essential and advanced chemicals, empowering scientists and researchers to drive progress in science and industry.

### Contact

Address: 3281 E Guasti Rd  
Ontario, CA 91761, United States  
Phone: (601) 213-4426  
Email: [info@benchchem.com](mailto:info@benchchem.com)