

potential off-target effects of Lly-283

Author: BenchChem Technical Support Team. **Date:** April 2026

Compound of Interest

Compound Name: Lly-283
Cat. No.: B15583804

[Get Quote](#)

Lly-283 Technical Support Center

Welcome to the technical support center for **Lly-283**, a potent and selective inhibitor of Protein Arginine Methyltransferase 5 (PRMT5). This resource is designed for researchers, scientists, and drug development professionals to provide guidance on the use of **Lly-283** in your experiments and to address potential issues you may encounter.

Frequently Asked Questions (FAQs)

Q1: What is the primary mechanism of action of **Lly-283**?

A1: **Lly-283** is a potent, SAM-competitive inhibitor of PRMT5.^[1] It directly binds to the S-adenosylmethionine (SAM) binding pocket of the PRMT5:MEP50 complex, preventing the transfer of methyl groups to its protein substrates.^{[2][3]} PRMT5 is a type II arginine methyltransferase that catalyzes the formation of symmetric dimethylarginine (sDMA) on both histone and non-histone proteins, which play crucial roles in RNA processing, signal transduction, and transcriptional regulation.^{[2][4][5]}

Q2: How selective is **Lly-283**?

A2: **Lly-283** is a highly selective inhibitor of PRMT5. It has been screened against a panel of 32 other methyltransferases and demonstrates over 100-fold selectivity for PRMT5.^{[1][2]} Its

diastereomer, Lly-284, is significantly less active and serves as an excellent negative control for experiments to distinguish on-target from potential off-target effects.[2]

Q3: What are the known downstream effects of **Lly-283** treatment?

A3: By inhibiting PRMT5, **Lly-283** leads to a reduction in symmetric dimethylarginine levels on various cellular proteins. A key downstream effect is the disruption of spliceosome function through the reduced methylation of Sm proteins (e.g., SmB/B').[2] This can lead to alternative splicing of certain pre-mRNAs, such as MDM4. The altered splicing of MDM4 can induce the p53 pathway, contributing to cell cycle arrest and apoptosis.[2] However, the antiproliferative effects of **Lly-283** are not solely dependent on a functional p53 pathway.[2]

Q4: In which cell lines is **Lly-283** expected to be most effective?

A4: **Lly-283** has demonstrated broad anti-proliferative activity across a range of cancer cell lines, with particular sensitivity noted in hematological, skin, lung, ovarian, and gastric cancer cell lines.[2] However, the sensitivity of different cell lines can vary. For example, a study across 46 patient-derived glioblastoma stem cell (GSC) lines showed differential sensitivities to **Lly-283**. [6]

Q5: What is the recommended solvent and storage for **Lly-283**?

A5: **Lly-283** is soluble in DMSO.[7] For long-term storage, the powdered form should be kept at -20°C for up to 3 years. Once dissolved in a solvent like DMSO, the stock solution should be stored at -80°C for up to one year to maintain stability. Avoid repeated freeze-thaw cycles.[3]

Troubleshooting Guides

Issue 1: Inconsistent IC50 values in cell-based proliferation assays.

- Potential Cause 1: Cell Seeding Density. The density at which cells are plated can significantly impact their growth rate and sensitivity to inhibitors.
 - Troubleshooting Step: Optimize cell seeding density for your specific cell line to ensure they are in the exponential growth phase during the assay. Ensure consistent seeding density across all plates and experiments.

- Potential Cause 2: Assay Duration. The anti-proliferative effects of PRMT5 inhibition can be slow to manifest in some cell lines.
 - Troubleshooting Step: A 7-day proliferation assay is often used to assess the effects of **Lly-283**.^[2] If you are using a shorter duration, consider extending the incubation time to allow for the full effect of the inhibitor to be observed.
- Potential Cause 3: Compound Stability. **Lly-283**, like any chemical compound, can degrade over time, especially in solution or when exposed to light.
 - Troubleshooting Step: Prepare fresh dilutions of **Lly-283** from a frozen stock for each experiment. Ensure proper storage of the stock solution at -80°C.^[3]

Issue 2: Weak or no effect of **Lly-283** in cellular assays despite potent biochemical activity.

- Potential Cause 1: Cell Permeability. While **Lly-283** has shown good cellular activity, differences in cell membrane composition could potentially affect its uptake in certain cell lines.
 - Troubleshooting Step: If you suspect poor permeability, you may consider using a positive control cell line known to be sensitive to **Lly-283**, such as A375.^[2]
- Potential Cause 2: Cell Line Resistance. Some cell lines may have intrinsic or acquired resistance to PRMT5 inhibition.
 - Troubleshooting Step: Confirm that your target cell line expresses PRMT5. Resistance can arise from a drug-induced transcriptional state switch.^[8] It's advisable to test a panel of cell lines to identify those most sensitive to **Lly-283**.
- Potential Cause 3: Insufficient Incubation Time. The downstream effects of PRMT5 inhibition, such as changes in splicing and protein expression, take time to accumulate.
 - Troubleshooting Step: Conduct a time-course experiment (e.g., 24, 48, 72 hours) to determine the optimal treatment duration to observe a significant effect on your readout of interest (e.g., sDMA levels).

Issue 3: Difficulty in detecting changes in symmetric dimethylarginine (sDMA) levels by Western Blot.

- Potential Cause 1: Antibody Quality. The quality of the anti-sDMA antibody is critical for a successful Western blot.
 - Troubleshooting Step: Use a well-validated antibody specific for symmetric dimethylarginine. Include positive and negative controls (e.g., lysate from **Lly-283** treated and untreated cells) to verify antibody performance.
- Potential Cause 2: Insufficient Protein Loading. If the target protein is of low abundance, the sDMA signal may be weak.
 - Troubleshooting Step: Increase the amount of protein loaded onto the gel. Enrichment of your target protein through immunoprecipitation may be necessary.
- Potential Cause 3: Inefficient Protein Transfer. Poor transfer of proteins from the gel to the membrane can result in weak signals.
 - Troubleshooting Step: Verify transfer efficiency using a reversible stain like Ponceau S. For high molecular weight proteins, optimize transfer time and buffer composition.^[9]

Data Presentation

Table 1: In Vitro and Cellular Potency of **Lly-283**

Assay Type	Target/Cell Line	IC50/EC50 (nM)	Reference
In Vitro Enzyme Inhibition	PRMT5:MEP50 complex	22 ± 3	[2]
Cellular Methylation (SmB/B')	MCF7 cells	25 ± 1	[2]
MDM4 Splicing	A375 cells	37 ± 3	[2]
Cell Proliferation	A375 (skin cancer)	37	[2]
Cell Proliferation	A2058 (skin cancer)	13	[2]
Cell Proliferation	OVCAR-3 (ovarian cancer)	32	[2]
Cell Proliferation	NCI-H2122 (lung cancer)	27	[2]

Table 2: Selectivity of **Lly-283** against other Methyltransferases

Methyltransferase	% Inhibition at 1 μ M Lly-283	% Inhibition at 10 μ M Lly-283	Reference
PRMT5	>95%	>95%	[2]
Other 32 Methyltransferases	Generally <10%	Not specified	[2]

Experimental Protocols

Cell Proliferation Assay (e.g., MTT/MTS)

- Cell Seeding: Plate cells in a 96-well plate at a pre-determined optimal density and allow them to adhere overnight.
- Compound Preparation: Prepare serial dilutions of **Lly-283** in the appropriate cell culture medium. A typical concentration range would be from 1 nM to 10 μ M. Include a vehicle control (e.g., 0.1% DMSO).

- Treatment: Remove the overnight culture medium and add the medium containing the different concentrations of **Lly-283**.
- Incubation: Incubate the plates for the desired period (e.g., 3 to 7 days) at 37°C in a humidified CO2 incubator.
- Detection: Add the MTT or MTS reagent to each well according to the manufacturer's instructions and incubate for 2-4 hours.
- Measurement: If using MTT, add the solubilization solution. Measure the absorbance at the appropriate wavelength using a microplate reader.
- Data Analysis: Calculate cell viability as a percentage of the vehicle-treated control and plot a dose-response curve to determine the IC50 value.

Western Blot for Symmetric Dimethylarginine (sDMA)

- Cell Lysis: Treat cells with **Lly-283** for the desired time and concentration. Harvest and lyse the cells in RIPA buffer supplemented with protease and phosphatase inhibitors.
- Protein Quantification: Determine the protein concentration of each lysate using a BCA or Bradford assay.
- SDS-PAGE: Denature equal amounts of protein (e.g., 20-40 µg) in Laemmli buffer and separate them on an SDS-polyacrylamide gel.
- Protein Transfer: Transfer the separated proteins to a PVDF or nitrocellulose membrane.
- Blocking: Block the membrane with 5% non-fat dry milk or BSA in TBST for 1 hour at room temperature.
- Primary Antibody Incubation: Incubate the membrane with a validated primary antibody against symmetric dimethylarginine (e.g., anti-sDMA) overnight at 4°C.
- Secondary Antibody Incubation: Wash the membrane with TBST and incubate with an HRP-conjugated secondary antibody for 1 hour at room temperature.

- Detection: Visualize the protein bands using an enhanced chemiluminescence (ECL) substrate and an imaging system.
- Normalization: To ensure equal loading, strip and re-probe the membrane with an antibody against a loading control protein (e.g., β -actin or GAPDH) or a total protein stain.

Mandatory Visualizations

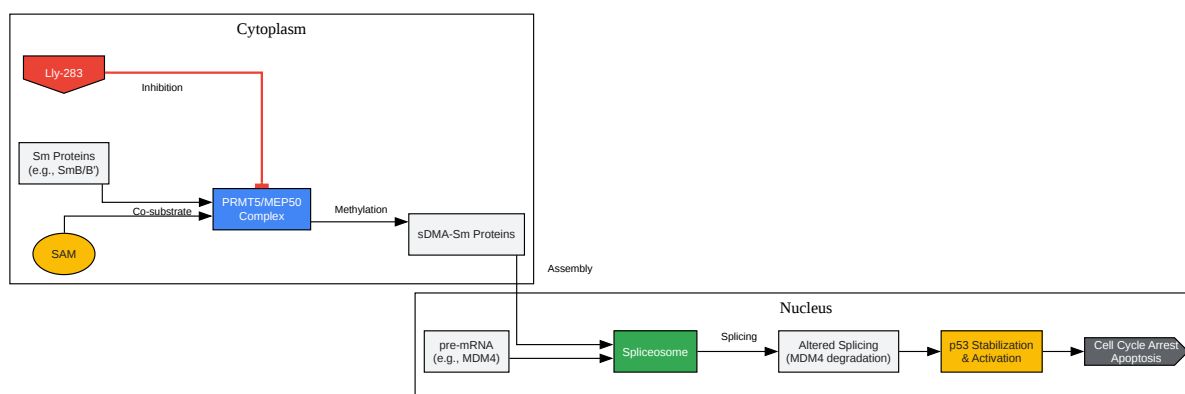

[Click to download full resolution via product page](#)

Caption: PRMT5 signaling pathway and the inhibitory effect of **Lly-283**.

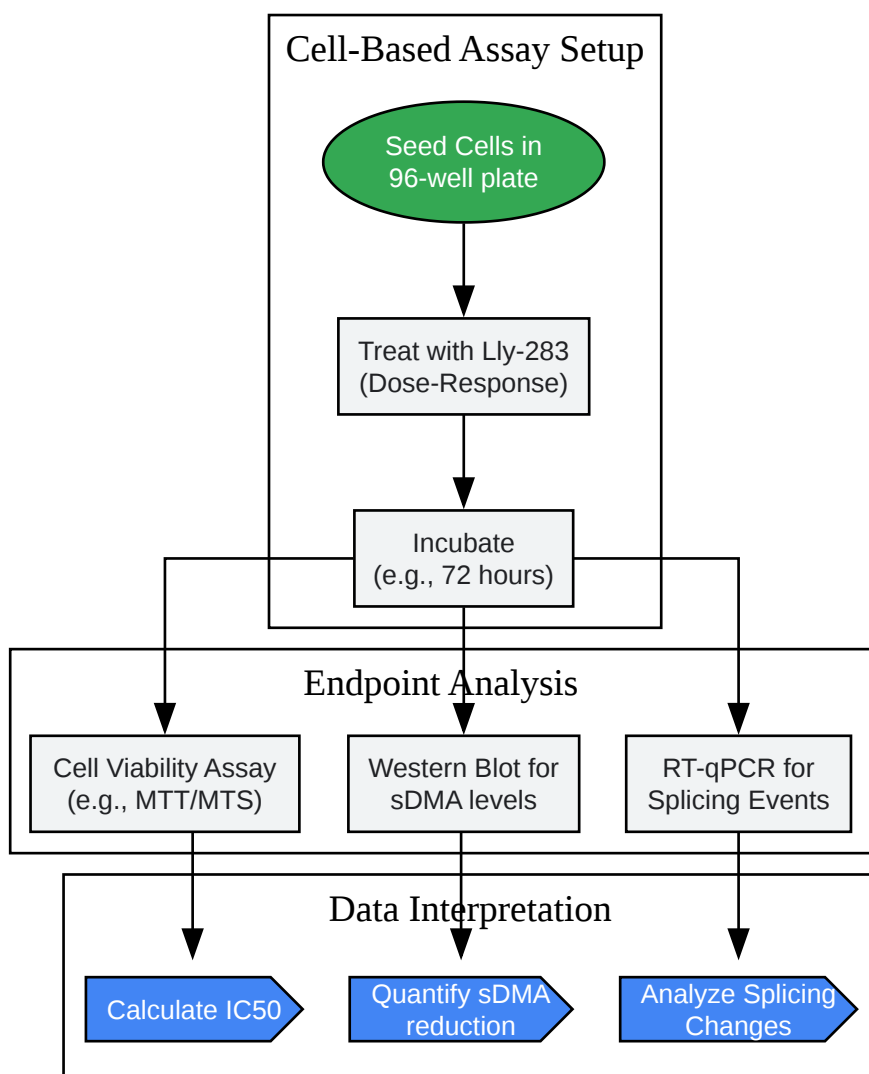

[Click to download full resolution via product page](#)

Caption: General experimental workflow for characterizing **Lly-283** effects.

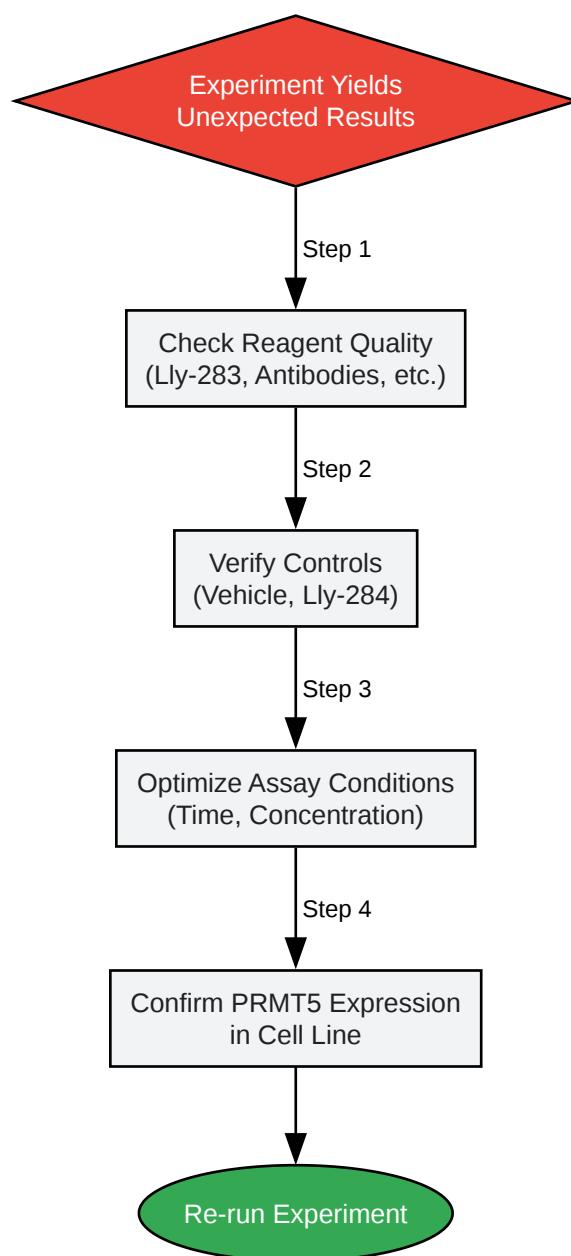

[Click to download full resolution via product page](#)

Caption: A logical approach to troubleshooting **Lly-283** experiments.

Need Custom Synthesis?

BenchChem offers custom synthesis for rare earth carbides and specific isotopic labeling.

Email: info@benchchem.com or [Request Quote Online](#).

References

- [1. LLY-283 | Ligand page | IUPHAR/BPS Guide to PHARMACOLOGY \[guidetopharmacology.org\]](#)
- [2. LLY-283, a Potent and Selective Inhibitor of Arginine Methyltransferase 5, PRMT5, with Antitumor Activity - PMC \[pmc.ncbi.nlm.nih.gov\]](#)
- [3. selleckchem.com \[selleckchem.com\]](#)
- [4. LLY-283, a Potent and Selective Inhibitor of Arginine Methyltransferase 5, PRMT5, with Antitumor Activity - PubMed \[pubmed.ncbi.nlm.nih.gov\]](#)
- [5. scholars.mssm.edu \[scholars.mssm.edu\]](#)
- [6. researchgate.net \[researchgate.net\]](#)
- [7. lifetechindia.com \[lifetechindia.com\]](#)
- [8. Acquired resistance to PRMT5 inhibition induces concomitant collateral sensitivity to paclitaxel - PMC \[pmc.ncbi.nlm.nih.gov\]](#)
- [9. Troubleshooting Issues in Western Blot Process - e-Blot \[e-blot.com\]](#)
- [To cite this document: BenchChem. \[potential off-target effects of Lly-283\]. BenchChem, \[2026\]. \[Online PDF\]. Available at: \[https://www.benchchem.com/product/b15583804/docs#potential-off-target-effects-of-lly-283\]](#)

Disclaimer & Data Validity:

The information provided in this document is for Research Use Only (RUO) and is strictly not intended for diagnostic or therapeutic procedures. While BenchChem strives to provide accurate protocols, we make no warranties, express or implied, regarding the fitness of this product for every specific experimental setup.

Technical Support: The protocols provided are for reference purposes. Unsure if this reagent suits your experiment?

Need Industrial/Bulk Grade? [Request Custom Synthesis Quote](#)

BenchChem

Our mission is to be the trusted global source of essential and advanced chemicals, empowering scientists and researchers to drive progress in science and industry.

Contact

Address: 3281 E Guasti Rd

Ontario, CA 91761, United States

Phone: (601) 213-4426

Email: info@benchchem.com

[Contact our Ph.D. Support Team for a compatibility check](#)