

# The Discovery and Development of Pycr1-IN-1: A Technical Guide

**Author:** BenchChem Technical Support Team. **Date:** April 2026

## Compound of Interest

Compound Name: Pycr1-IN-1

Cat. No.: B15583329

[Get Quote](#)

For Researchers, Scientists, and Drug Development Professionals

## Abstract

This technical guide details the discovery and initial development of **Pycr1-IN-1**, a small molecule inhibitor of Pyrroline-5-Carboxylate Reductase 1 (PYCR1). PYCR1 is a critical enzyme in the proline biosynthesis pathway and has been identified as a promising therapeutic target in oncology due to its upregulation in various cancers and its role in supporting tumor growth and survival.[1][2] This document outlines the fragment-based drug discovery approach that led to the identification of **Pycr1-IN-1**, its biochemical and cell-based activities, and the experimental protocols utilized in its characterization. Structure-activity relationship (SAR) studies of the initial hit and subsequent analogs are presented, providing a foundational understanding for future drug development efforts.

## Introduction: The Rationale for Targeting PYCR1

PYCR1 catalyzes the final step in proline biosynthesis, the NAD(P)H-dependent reduction of pyrroline-5-carboxylate (P5C) to proline.[2] Proline metabolism is increasingly recognized for its significant role in the metabolic reprogramming of cancer cells, contributing to processes such as redox balance, apoptosis prevention, and biomass production.[2] Numerous studies have

demonstrated that PYCR1 is overexpressed in a wide range of malignancies, and its elevated expression often correlates with poor patient prognosis.[3] Knockdown of the PYCR1 gene has been shown to inhibit tumor growth, validating it as a compelling target for anticancer therapy.[4] The development of small molecule inhibitors of PYCR1, such as **Pycr1-IN-1**, offers a promising strategy to therapeutically exploit the dependence of cancer cells on proline metabolism.

## Discovery of Pycr1-IN-1: A Fragment-Based Approach

**Pycr1-IN-1** (also referred to as compound 4) was discovered through a fragment-based screening and subsequent chemical optimization effort.[4]

### Initial Hit Identification

A focused screening of a library of fragment-like compounds identified pargyline as a modest inhibitor of PYCR1.[2][4] Pargyline, a known monoamine oxidase inhibitor, served as the starting point for a medicinal chemistry campaign to improve potency and explore the structure-activity relationship for PYCR1 inhibition.[4]

### Structure-Activity Relationship (SAR) Studies

Starting from the pargyline scaffold, a series of over 60 analogs were synthesized to probe the key determinants of activity.[4] These studies led to the identification of compound 4, **Pycr1-IN-1**, which demonstrated significantly improved inhibitory activity against PYCR1.[4]

Table 1: Structure-Activity Relationship of Pargyline Analogs Against PYCR1[4]

Compound	R1	R2	R3	IC50 ( $\mu\text{M}$ )
Pargyline	H	H	H	~200
Pycr1-IN-1 (4)	Br	H	H	8.8
Analog A	Cl	H	H	>100
Analog B	F	H	H	>100
Analog C	H	Br	H	>100
Analog D	H	H	Br	>100

Note: The full list of synthesized analogs and their activities can be found in the primary literature. This table highlights key analogs to illustrate the SAR.

The SAR studies revealed that substitution on the phenyl ring of the pargyline scaffold was critical for activity, with a bromine atom at the R1 position affording the most potent compound, **Pycr1-IN-1**.<sup>[4]</sup>

## Quantitative Data

**Pycr1-IN-1** has been characterized by its in vitro potency and its effects on cancer cell lines.

Table 2: In Vitro Activity of **Pycr1-IN-1**

Parameter	Value	Cell Line/Assay Condition	Reference
IC50	8.8 $\mu\text{M}$	Recombinant human PYCR1 enzyme assay	[4]
Cellular Proline Reduction	~50% at 1 $\mu\text{M}$	SUM-159-PT human breast cancer cells	[4]
Inhibition of Cell Proliferation	40% reduction at 10 $\mu\text{M}$	MDA-MB-231 breast cancer cells	[4]
Inhibition of Cell Proliferation	30% reduction at 10 $\mu\text{M}$	SUM-159-PT breast cancer cells	[4]

## Mechanism of Action and Signaling Pathways

**Pycr1-IN-1** exerts its primary effect by directly inhibiting the enzymatic activity of PYCR1, thereby blocking the synthesis of proline.[4] This leads to a depletion of intracellular proline levels, which can have several downstream consequences for cancer cells. While direct studies on the signaling pathways affected by **Pycr1-IN-1** are limited, the effects of PYCR1 knockdown provide strong indications of the likely downstream consequences of its inhibition.

PYCR1 has been shown to be involved in the activation of key pro-survival signaling pathways, including the PI3K/AKT/mTOR and MAPK/ERK pathways.[5][6] Therefore, it is hypothesized that by inhibiting PYCR1, **Pycr1-IN-1** may lead to the downregulation of these critical cancer-promoting pathways.

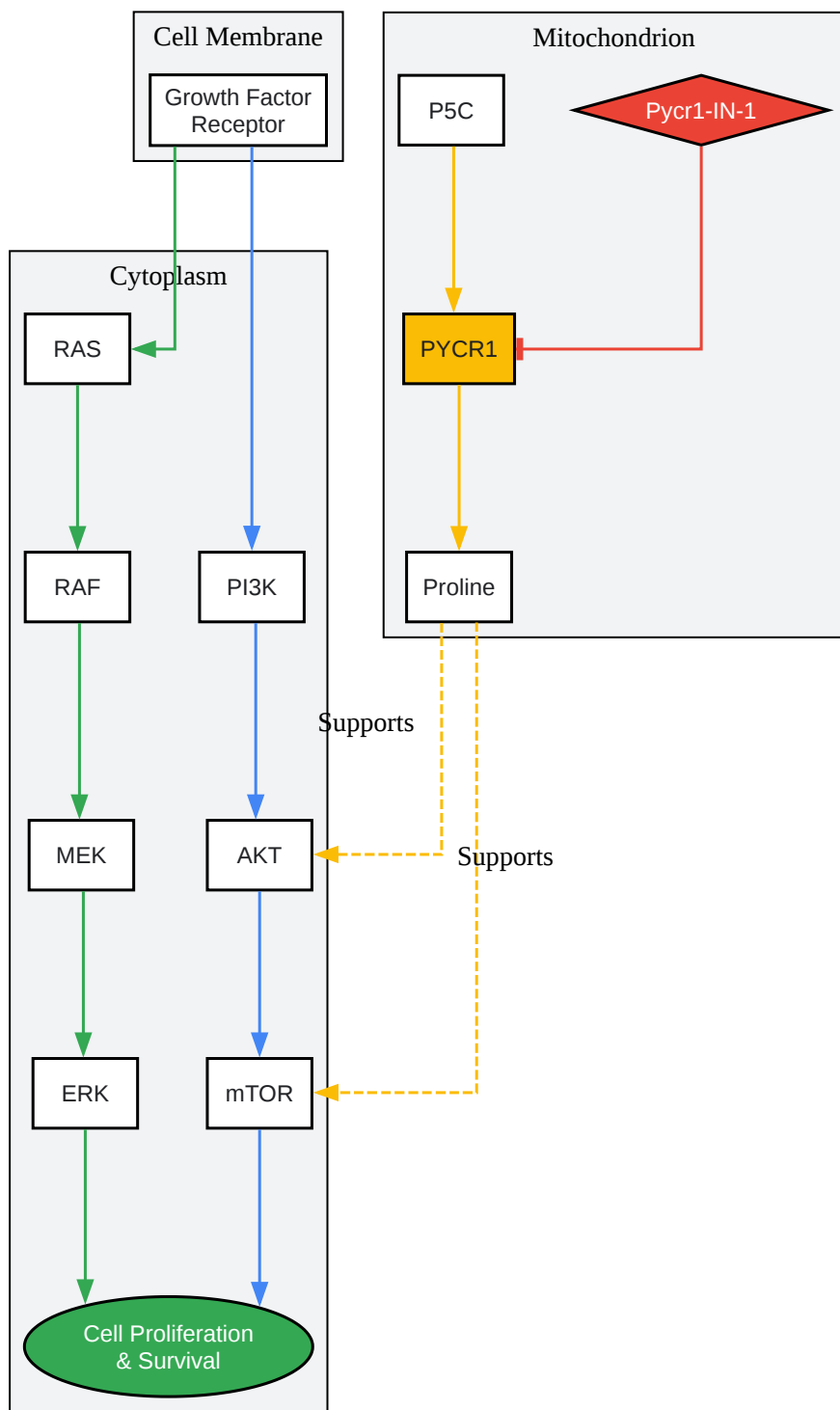

[Click to download full resolution via product page](#)

**Fig. 1:** Hypothesized signaling impact of **Pycr1-IN-1**.

## Experimental Protocols

The following are detailed methodologies for the key experiments cited in the characterization of **Pycr1-IN-1**, based on the discovery publication.[4]

### PYCR1 Enzyme Inhibition Assay

Objective: To determine the in vitro potency of compounds in inhibiting recombinant human PYCR1.

Materials:

- Recombinant human PYCR1 enzyme
- Assay buffer: 50 mM Tris-HCl (pH 7.5), 100 mM KCl, 10 mM MgCl<sub>2</sub>, 0.01% Tween-20
- NADPH (cofactor)
- Pyrroline-5-carboxylate (P5C) (substrate)
- Test compounds (e.g., **Pycr1-IN-1**) dissolved in DMSO
- 384-well microplate
- Plate reader capable of measuring absorbance at 340 nm

Procedure:

- Prepare a solution of recombinant PYCR1 in assay buffer.
- Add 2  $\mu$ L of test compound at various concentrations (typically a 10-point serial dilution) to the wells of a 384-well plate.
- Add 10  $\mu$ L of the PYCR1 enzyme solution to each well and incubate for 15 minutes at room temperature.
- Initiate the reaction by adding 10  $\mu$ L of a substrate/cofactor mix containing NADPH and P5C to each well.

- Immediately measure the decrease in absorbance at 340 nm every 30 seconds for 15 minutes. The decrease in absorbance corresponds to the oxidation of NADPH.
- Calculate the rate of reaction for each compound concentration.
- Determine the IC50 value by plotting the percent inhibition against the log of the compound concentration and fitting the data to a four-parameter logistic equation.

## Cellular Proline Level Assay

Objective: To measure the effect of **Pycr1-IN-1** on intracellular proline levels in cancer cells.

Materials:

- SUM-159-PT breast cancer cells
- Cell culture medium and supplements
- **Pycr1-IN-1**
- LC-MS/MS system
- Reagents for cell lysis and protein precipitation (e.g., methanol)

Procedure:

- Seed SUM-159-PT cells in 6-well plates and allow them to adhere overnight.
- Treat the cells with varying concentrations of **Pycr1-IN-1** (e.g., 1, 5, 20, 100  $\mu$ M) or vehicle control (DMSO) for 24 hours.
- After treatment, wash the cells with ice-cold PBS.
- Lyse the cells and precipitate proteins using a cold methanol-based solution.
- Centrifuge the samples to pellet the protein and collect the supernatant containing the metabolites.
- Analyze the supernatant for proline levels using a validated LC-MS/MS method.

- Normalize the proline levels to the total protein content or cell number.

## Cell Proliferation Assay

Objective: To assess the effect of **Pycr1-IN-1** on the proliferation of cancer cells.

Materials:

- MDA-MB-231 and SUM-159-PT breast cancer cells
- Cell culture medium and supplements
- **Pycr1-IN-1**
- Exogenous L-proline
- Cell counting solution (e.g., CellTiter-Glo®) or crystal violet stain
- 96-well plates
- Plate reader

Procedure:

- Seed MDA-MB-231 and SUM-159-PT cells in 96-well plates at a low density.
- Allow the cells to adhere overnight.
- Treat the cells with **Pycr1-IN-1** at a fixed concentration (e.g., 10  $\mu$ M) in the presence or absence of exogenous L-proline. Include vehicle-treated cells as a control.
- Incubate the cells for a period of 1 to 5 days.
- At the end of the incubation period, measure cell viability using a suitable method (e.g., CellTiter-Glo® assay or crystal violet staining).
- Calculate the percent reduction in cell proliferation compared to the vehicle-treated control.

## Experimental and Developmental Workflow

The discovery and initial development of **Pycr1-IN-1** followed a structured workflow, as depicted below.

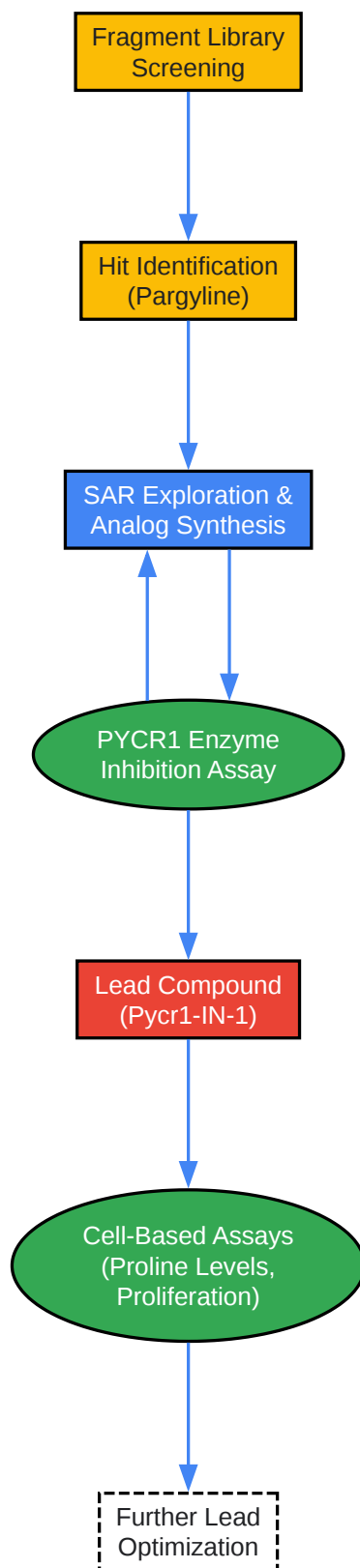

[Click to download full resolution via product page](#)

**Fig. 2:** Discovery workflow for **Pycr1-IN-1**.

## Conclusion and Future Directions

**Pycr1-IN-1** represents a first-generation tool compound for the inhibition of PYCR1. Its discovery through a fragment-based approach demonstrates a viable strategy for targeting this enzyme. The initial characterization shows that **Pycr1-IN-1** can effectively inhibit its target in vitro and impact proline metabolism and cell proliferation in cancer cell lines.

Future efforts should focus on several key areas:

- **Improving Potency and Selectivity:** Further optimization of the **Pycr1-IN-1** scaffold is needed to enhance its potency and to assess its selectivity against other PYCR isoforms (PYCR2 and PYCR3).
- **Elucidating Downstream Signaling Effects:** Detailed studies are required to confirm the hypothesized impact of **Pycr1-IN-1** on pro-survival signaling pathways such as PI3K/AKT and MAPK/ERK.
- **In Vivo Efficacy Studies:** Evaluation of **Pycr1-IN-1** or its improved analogs in preclinical in vivo cancer models is a critical next step to assess its therapeutic potential.
- **Pharmacokinetic Profiling:** Characterization of the absorption, distribution, metabolism, and excretion (ADME) properties of future lead compounds will be essential for their development as clinical candidates.

In summary, the discovery of **Pycr1-IN-1** provides a valuable starting point for the development of novel anticancer agents targeting the proline biosynthesis pathway. Continued research in this area holds the potential to deliver new therapeutic options for a variety of cancers.

### *Need Custom Synthesis?*

*BenchChem offers custom synthesis for rare earth carbides and specific isotopic labeling.*

*Email: [info@benchchem.com](mailto:info@benchchem.com) or [Request Quote Online](#).*

## References

- [1. A fragment-like approach to PYCR1 inhibition - PubMed \[pubmed.ncbi.nlm.nih.gov\]](#)
- [2. The key enzyme PYCR1 in proline metabolism: a dual driver of cancer progression and fibrotic remodeling - PMC \[pmc.ncbi.nlm.nih.gov\]](#)
- [3. Survival and clinicopathological significance of PYCR1 expression in cancer: A meta-analysis - PMC \[pmc.ncbi.nlm.nih.gov\]](#)
- [4. pureportal.strath.ac.uk \[pureportal.strath.ac.uk\]](#)
- [5. PYCR1 promotes liver cancer cell growth and metastasis by regulating IRS1 expression through lactylation modification - PMC \[pmc.ncbi.nlm.nih.gov\]](#)
- [6. tandfonline.com \[tandfonline.com\]](#)
- To cite this document: BenchChem. [The Discovery and Development of Pycr1-IN-1: A Technical Guide]. BenchChem, [2026]. [Online PDF]. Available at: [\[https://www.benchchem.com/product/b15583329/docs#the-discovery-and-development-of-pycr1-in-1-a-technical-guide\]](https://www.benchchem.com/product/b15583329/docs#the-discovery-and-development-of-pycr1-in-1-a-technical-guide)

---

### Disclaimer & Data Validity:

The information provided in this document is for Research Use Only (RUO) and is strictly not intended for diagnostic or therapeutic procedures. While BenchChem strives to provide accurate protocols, we make no warranties, express or implied, regarding the fitness of this product for every specific experimental setup.

**Technical Support:** The protocols provided are for reference purposes. Unsure if this reagent suits your experiment?

**Need Industrial/Bulk Grade?** [Request Custom Synthesis Quote](#)

# BenchChem

Our mission is to be the trusted global source of essential and advanced chemicals, empowering scientists and researchers to drive progress in science and industry.

## Contact

Address: 3281 E Guasti Rd

Ontario, CA 91761, United States

Phone: (601) 213-4426

Email: [info@benchchem.com](mailto:info@benchchem.com)

[Contact our Ph.D. Support Team for a compatibility check](#)