

Technical Support Center: T-448 (EOS-448/Belrestotug)

Author: BenchChem Technical Support Team. **Date:** April 2026

Compound of Interest

Compound Name: T-448
Cat. No.: B15583452

[Get Quote](#)

A Note on **T-448**: The designation "**T-448**" can refer to different compounds in scientific literature. This technical support center focuses on EOS-448 (also known as Belrestotug or GSK4428859A), an antagonistic anti-TIGIT human immunoglobulin G1 (hIgG1) antibody.^{[1][2]} This resource is intended for researchers, scientists, and drug development professionals working with this specific molecule.

Frequently Asked Questions (FAQs)

Q1: What is the primary mechanism of action for EOS-448?

A1: EOS-448 is an antagonistic anti-TIGIT antibody with a multifaceted mechanism of action designed to enhance anti-tumor immune responses.^{[3][4]} Its primary functions are:

- **Blocking the TIGIT-CD155/CD112 interaction:** By binding to TIGIT, EOS-448 prevents its interaction with its ligands (CD155 and CD112), which in turn allows the co-stimulatory receptor CD226 to bind these ligands, leading to the activation of T cells and Natural Killer (NK) cells.^[5]
- **Fc-gamma Receptor (FcγR) Engagement:** As an IgG1 antibody, EOS-448's functional Fc domain engages Fcγ receptors on myeloid and NK cells.^{[1][4]} This engagement leads to:

- Activation of antigen-presenting cells (APCs).[4]
- Antibody-dependent cell-mediated cytotoxicity (ADCC) and antibody-dependent cell-mediated phagocytosis (ADCP) of TIGIT-expressing cells.[6]
- Preferential depletion of immunosuppressive regulatory T cells (Tregs) and terminally exhausted CD8+ T cells, which have high TIGIT expression.[1][3][4]

Q2: What are the key therapeutic effects of EOS-448 observed in preclinical and clinical studies?

A2: Preclinical and clinical data have shown that EOS-448 can:

- Activate effector T cells.[3]
- Modulate antigen-presenting cells.[4]
- Deplete regulatory T cells (Tregs) and terminally exhausted T cells.[3]
- Increase the effector CD8/Treg ratio in the blood of treated patients.[1][3]
- Show early signs of clinical activity in advanced cancers, with one confirmed partial response and nine stable diseases out of 20 evaluable patients in a Phase 1 dose-escalation study.[5]

Q3: Why is the IgG1 isotype important for EOS-448's function?

A3: The IgG1 isotype provides a functional Fc domain, which is crucial for the full range of EOS-448's anti-tumor activity. Studies comparing Fc-engaging formats (like IgG1) to Fc-dead or Fc-silent formats have demonstrated that FcγR engagement is necessary for the depletion of Tregs and the activation of myeloid cells, which contributes significantly to its anti-tumor effects. [1][4] Only the Fc-engaging isotype has been shown to induce a strong anti-tumor effect in murine models, which correlates with Treg depletion and CD8 T cell activation within the tumor microenvironment.[1][3]

Troubleshooting Guide

Q1: My in vitro T-cell activation assay with EOS-448 is showing minimal or no effect. What could be the issue?

A1:

- Missing FcγR-expressing cells: The full effect of EOS-448, particularly the activation of antigen-presenting cells and depletion of Tregs, is dependent on FcγR engagement.[1][4] Ensure your co-culture system includes FcγR-expressing cells like monocytes, macrophages, or NK cells.
- Incorrect EOS-448 isotype: If you are using a non-Fc-engaging isotype (e.g., an Fc-silent or Fc-dead mutant) as your primary antibody, you will not observe the effects mediated by FcγR. These formats are typically used as experimental controls.[1]
- Low TIGIT expression on target cells: The target T cells in your assay must express TIGIT. Confirm TIGIT expression levels on your effector cells and Tregs using flow cytometry.

Q2: I am not observing Treg depletion in my experiments. Why might this be?

A2:

- Use of an Fc-dead/silent anti-TIGIT antibody: Treg depletion is primarily mediated through ADCC/ADCP via FcγR engagement.[6] An antibody with a non-functional Fc domain will not effectively deplete these cells and is a common negative control.[1]
- Insufficient effector cells: Ensure a sufficient number of effector cells (like NK cells) capable of mediating ADCC are present in your assay.
- Low TIGIT expression on Tregs: While Tregs typically have high TIGIT expression, it's advisable to confirm this in your specific experimental system.[6]

Q3: I see an increase in CD8+ T cell proliferation (e.g., Ki67 expression), but no significant anti-tumor activity in my mouse model. What should I investigate?

A3:

- Tumor microenvironment (TME): The TME may contain other immunosuppressive mechanisms that are not addressed by TIGIT blockade alone. Combination therapy, for example with an anti-PD-1 antibody, has shown synergistic effects in preclinical models.[1]

- Insufficient Treg depletion: The anti-tumor effect of EOS-448 is strongly correlated with Treg depletion within the tumor.[3] Assess the level of Treg depletion in the TME.
- Timing and dosage: The timing and dosage of EOS-448 administration may need to be optimized for your specific tumor model.

Data Presentation

Table 1: Summary of Clinical Observations from Phase 1 Dose-Escalation Study of EOS-448[5]

Metric	Observation	Number of Patients
Clinical Response	Confirmed Partial Response	1
Stable Disease	9	
Total Evaluable Patients	20	
Pharmacodynamics	Depletion of TIGIT+ suppressive and exhausted cells	Observed at all dose levels
Increased Ki67 expression in memory CD8 T cells during the first cycle	-	
Sustained depletion of suppressive Tregs	-	
Increased effector CD8/Treg ratio	-	

Experimental Protocols

Methodology for Pharmacodynamic Assessment by Flow Cytometry

This is a generalized protocol based on the methodologies described in the literature for assessing the pharmacodynamic effects of EOS-448.[1] Researchers should optimize this protocol for their specific experimental setup.

1. Objective: To assess the impact of EOS-448 on T cell populations (Tregs, effector CD8+ T cells) and their activation status in peripheral blood or tumor-infiltrating lymphocytes.
2. Sample Preparation:
 - Isolate peripheral blood mononuclear cells (PBMCs) from whole blood using density gradient centrifugation (e.g., Ficoll-Paque).
 - For tumor samples, create single-cell suspensions using mechanical dissociation and/or enzymatic digestion.
3. Antibody Staining:
 - Surface Staining: Incubate cells with a cocktail of fluorescently-conjugated antibodies against surface markers. A typical panel might include:
 - Lineage markers: CD3, CD4, CD8, CD45
 - Treg markers: CD25, CD127
 - TIGIT expression: Anti-TIGIT
 - Intracellular Staining (for Transcription Factors and Proliferation):
 - Fix and permeabilize cells using a commercially available kit (e.g., FoxP3/Transcription Factor Staining Buffer Set).
 - Incubate with antibodies against intracellular targets such as:
 - Treg identification: FoxP3
 - Proliferation marker: Ki67
4. Experimental Controls:
 - Isotype Controls: Use isotype control antibodies for each fluorochrome to determine background staining.

- Fluorescence Minus One (FMO) Controls: Use FMO controls to properly gate complex multicolor panels, especially for markers like Ki67 and FoxP3.
- Biological Controls:
 - Untreated/Vehicle Control: Samples from subjects or animals that have not received EOS-448.
 - Fc-dead/silent anti-TIGIT antibody: To demonstrate that certain effects (e.g., Treg depletion) are dependent on FcγR engagement.[\[1\]](#)

5. Data Acquisition and Analysis:

- Acquire stained samples on a multicolor flow cytometer.
- Analyze the data using appropriate software (e.g., FlowJo, FCS Express).
- Gating Strategy:
 - Gate on lymphocytes based on forward and side scatter.
 - Gate on single cells.
 - Gate on CD3+ T cells.
 - Within the T cell gate, separate CD4+ and CD8+ populations.
 - Within the CD4+ gate, identify Tregs (e.g., CD25+ FoxP3+).
 - Quantify the percentage of Ki67+ cells within the CD8+ T cell population to assess proliferation.
 - Calculate the ratio of CD8+ T cells to Tregs.

Visualizations

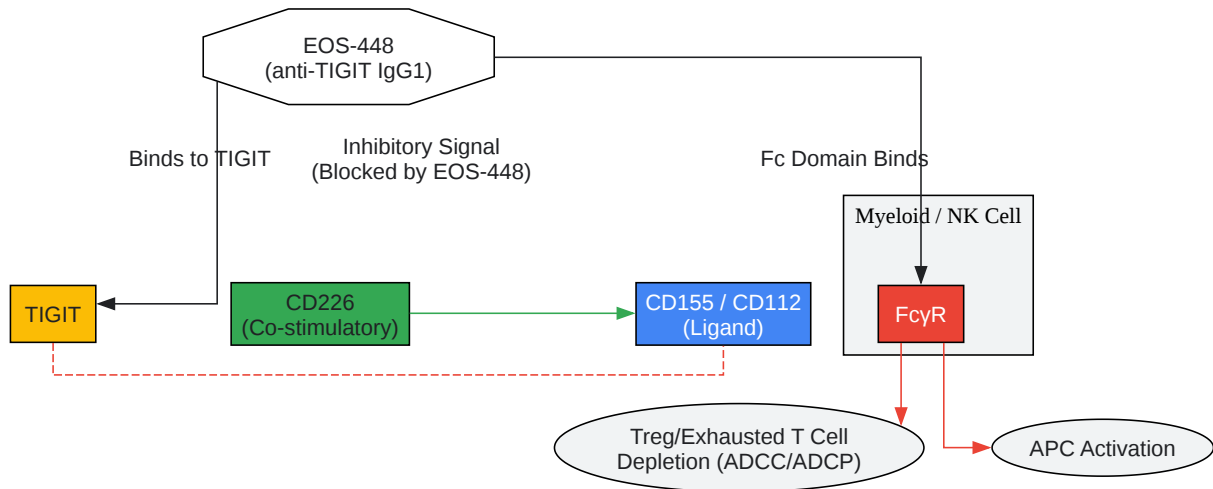

[Click to download full resolution via product page](#)

Caption: Multifaceted mechanism of action of EOS-448.

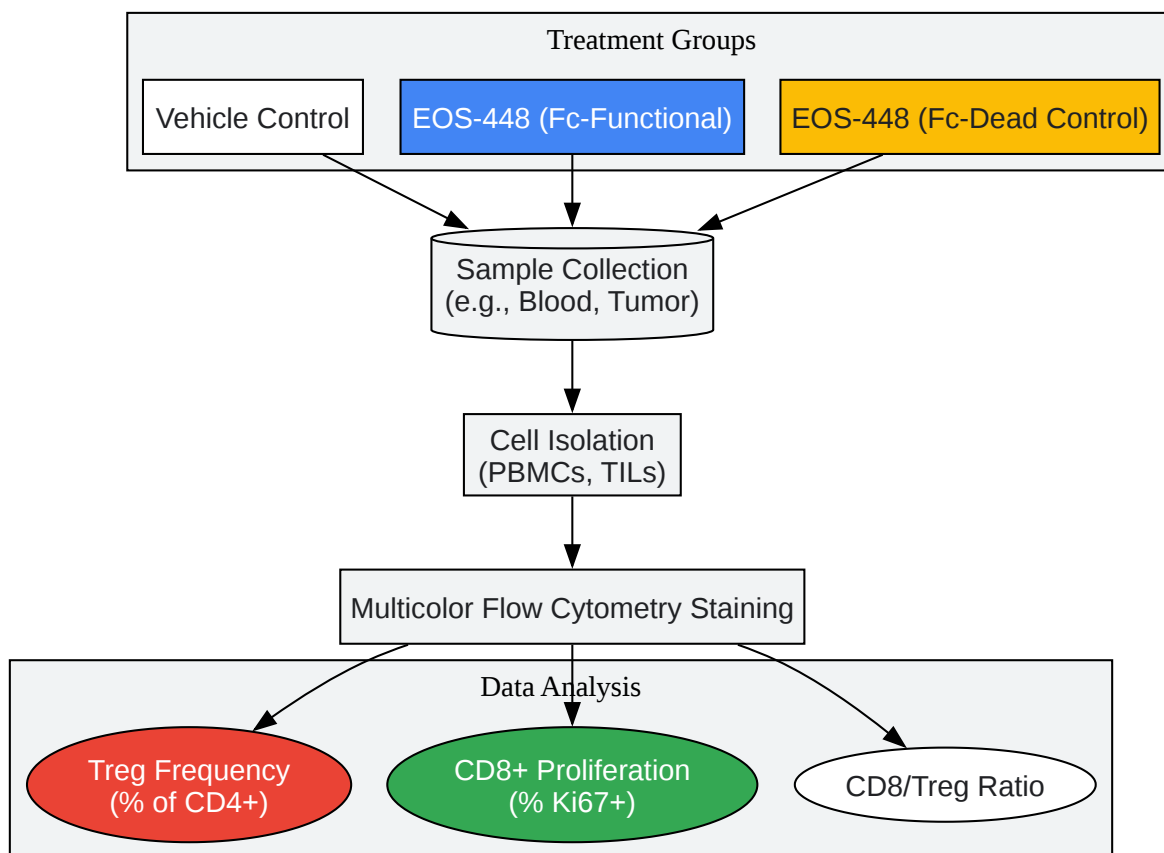

[Click to download full resolution via product page](#)

Caption: Experimental workflow for assessing EOS-448 pharmacodynamics.

Need Custom Synthesis?

BenchChem offers custom synthesis for rare earth carbides and specific isotopic labeling.

Email: info@benchchem.com or [Request Quote Online](#).

References

- [1. researchgate.net \[researchgate.net\]](#)
- [2. medchemexpress.com \[medchemexpress.com\]](#)
- [3. hbmpartners.com \[hbmpartners.com\]](#)
- [4. iTeos Announces New Data for its Anti-TIGIT Antibody, EOS-448, at the American Society of Hematology Annual Meeting and TIGIT Therapies Digital Summit 2021 - BioSpace \[biospace.com\]](#)
- [5. gsk.com \[gsk.com\]](#)
- [6. researchgate.net \[researchgate.net\]](#)
- To cite this document: BenchChem. [Technical Support Center: T-448 (EOS-448/Belrestotug)]. BenchChem, [2026]. [Online PDF]. Available at: [\[https://www.benchchem.com/product/b15583452/docs#technical-support-center-t-448-eos-448-belrestotug\]](https://www.benchchem.com/product/b15583452/docs#technical-support-center-t-448-eos-448-belrestotug)

Disclaimer & Data Validity:

The information provided in this document is for Research Use Only (RUO) and is strictly not intended for diagnostic or therapeutic procedures. While BenchChem strives to provide accurate protocols, we make no warranties, express or implied, regarding the fitness of this product for every specific experimental setup.

Technical Support: The protocols provided are for reference purposes. Unsure if this reagent suits your experiment?

Need Industrial/Bulk Grade? [Request Custom Synthesis Quote](#)

BenchChem

Our mission is to be the trusted global source of essential and advanced chemicals, empowering scientists and researchers to drive progress in science and industry.

Contact

Address: 3281 E Guasti Rd
Ontario, CA 91761, United States
Phone: (601) 213-4426
Email: info@benchchem.com

Contact our Ph.D. Support Team for a compatibility check