

Technical Support Center: Navigating LLY-283 High-Throughput Screening

Author: BenchChem Technical Support Team. **Date:** April 2026

Compound of Interest

Compound Name: *Lly-283*
Cat. No.: *B15583804*

[Get Quote](#)

This technical support center provides researchers, scientists, and drug development professionals with comprehensive troubleshooting guides and frequently asked questions (FAQs) to mitigate artifacts and ensure robust results when using the PRMT5 inhibitor, **LLY-283**, in high-throughput screening (HTS) campaigns.

Frequently Asked Questions (FAQs)

Q1: What is **LLY-283** and what is its mechanism of action?

A1: **LLY-283** is a potent and selective inhibitor of Protein Arginine Methyltransferase 5 (PRMT5).^{[1][2][3][4][5]} It functions as an S-adenosyl-L-methionine (SAM) competitive inhibitor, binding to the SAM pocket of the PRMT5:MEP50 complex.^{[6][7]} This prevents the transfer of a methyl group from SAM to arginine residues on substrate proteins. PRMT5 is a type II arginine methyltransferase that catalyzes the formation of symmetric dimethylarginine (SDMA) on various proteins involved in critical cellular processes, including RNA splicing, signal transduction, and transcriptional regulation.^{[2][3][5][8]}

Q2: What is the reported potency of **LLY-283**?

A2: **LLY-283** exhibits low nanomolar potency in both biochemical and cellular assays. The IC50 values are consistently reported in the range of 20-25 nM.[1][2][3][4][5][9] A diastereomer, LLY-284, is significantly less active and can be used as a negative control in experiments.[3][9]

Q3: What are the key cellular pathways affected by **LLY-283**?

A3: As a PRMT5 inhibitor, **LLY-283** impacts several critical cellular pathways:

- RNA Splicing: PRMT5 is essential for the proper assembly of the spliceosome. Inhibition by **LLY-283** can lead to aberrant alternative splicing of specific mRNAs, such as MDM4.[3][6]
- Signal Transduction: PRMT5 can modulate signaling pathways such as the EGFR, AKT, and hedgehog pathways through methylation of key components.[8] It has also been shown to regulate the RAS-ERK signaling cascade.[10]
- Transcriptional Regulation: PRMT5-mediated histone methylation can regulate gene expression.[8]
- DNA Damage Response: PRMT5 plays a role in DNA repair pathways.[11]

Q4: Are there known off-target effects for **LLY-283**?

A4: **LLY-283** is reported to be highly selective for PRMT5 over other methyltransferases.[7][9] However, as with any small molecule inhibitor, it is crucial to perform counter-screens and use appropriate controls to rule out potential off-target effects in your specific assay system.

Troubleshooting Guides

Issue 1: High Variability or Poor Z'-factor in Biochemical Assays

High variability in HTS assays can mask genuine hits. Common causes and solutions are outlined below:

Potential Cause	Troubleshooting Steps
Pipetting Errors	Ensure all pipettes are properly calibrated. Utilize automated liquid handlers for dispensing reagents and compounds to minimize human error. Prepare master mixes for reagents to be dispensed across a plate to ensure uniformity.
Reagent Instability	Use high-quality, fresh reagents, including the PRMT5 enzyme, substrate peptide, and SAM. Aliquot reagents to avoid repeated freeze-thaw cycles.
Suboptimal Assay Conditions	Verify that the assay buffer pH is consistently maintained, ideally between 6.5 and 8.5. Maintain a constant temperature, as PRMT5 activity is optimal around 37°C.[12]
Enzyme Inactivity	Confirm the activity of the purified PRMT5 enzyme with a known substrate and control inhibitor before initiating a screen. Ensure the enzyme is stored under optimal conditions.
Substrate Issues	Use fresh, high-quality peptide substrates. Determine the Michaelis-Menten constant (K_m) for the substrate and use a concentration at or near the K_m for competitive inhibitor screening.

Issue 2: Discrepancy Between Biochemical and Cellular Potency

A common challenge is observing potent activity in biochemical assays that does not translate to cellular models.

Potential Cause	Troubleshooting Steps
Poor Cell Permeability	Determine the cell permeability of LLY-283 in your specific cell line if this information is not readily available.
High Intracellular SAM Concentration	As a SAM-competitive inhibitor, the high intracellular concentration of SAM can compete with LLY-283 for binding to PRMT5, leading to a rightward shift in the IC50 value.[7] Consider using cell lines with lower intrinsic SAM levels if appropriate for the biological question.
Insufficient Incubation Time	The cellular effects of PRMT5 inhibition, such as changes in splicing or protein levels, may require a longer incubation time to manifest. Extend the inhibitor treatment duration to allow for adequate target engagement and downstream biological consequences.[12]
Compound Efflux	The compound may be actively transported out of the cells by efflux pumps. Co-incubation with known efflux pump inhibitors can help to investigate this possibility.
Compound Metabolism	LLY-283 may be rapidly metabolized within the cells. LC-MS/MS analysis of cell lysates can be used to determine the intracellular concentration and stability of the compound over time.

Issue 3: Assay Interference and False Positives

Assay artifacts can lead to the identification of false-positive hits. It is crucial to implement strategies to identify and eliminate these.

Potential Cause	Troubleshooting Steps
Compound Aggregation	Some compounds can form aggregates at high concentrations, leading to non-specific inhibition. Perform dose-response curves and look for steep Hill slopes, which can be indicative of aggregation. Include a detergent like Triton X-100 in the assay buffer to minimize aggregation.
Interference with Detection Method	For fluorescence-based assays, pre-screen compounds for auto-fluorescence at the excitation and emission wavelengths of your assay. For luminescence-based assays, test for compound-mediated quenching or enhancement of the signal.
Redox Activity	Compounds that are redox-active can interfere with assays that rely on redox-sensitive reagents. Consider using orthogonal assays with different detection methods to confirm hits.
Reactivity with Assay Components	Some compounds may react directly with assay components, such as the enzyme or substrate. Pre-incubation studies can help to identify time-dependent inhibition that may be due to covalent modification.

Quantitative Data Summary

Table 1: In Vitro and Cellular Potency of **LLY-283**

Assay Type	Target	Substrate	IC50 (nM)	Reference
Biochemical	PRMT5:MEP50	Histone H4 peptide	22 ± 3	[3]
Biochemical	PRMT5:MEP50	H4R3 derived peptide	~20	[9]
Cellular	PRMT5	Endogenous	25 ± 1	[3]
Cellular (SmBB' methylation)	PRMT5	SmBB'	25	[9]
Cellular (MDM4 splicing)	PRMT5	MDM4 pre-mRNA	~40	[9]

Table 2: Selectivity of **LLY-283**

Methyltransferase Panel	Fold Selectivity over PRMT5	Reference
32 Methyltransferases	>100	[7][9]

Experimental Protocols

Biochemical PRMT5 Inhibition Assay (Radiometric)

This protocol is adapted from methodologies used to characterize PRMT5 inhibitors.[3][12]

- Prepare Assay Buffer: 50 mM Tris-HCl pH 8.0, 10 mM NaCl, 1 mM EDTA, 1 mM DTT, and 0.01% Tween-20.
- Enzyme and Substrate Preparation: In a reaction tube, add the assay buffer, recombinant human PRMT5/MEP50 complex, and a biotinylated histone H4 peptide substrate.
- Compound Addition: Add serially diluted **LLY-283** or DMSO (vehicle control) to the reaction tubes and incubate for 15 minutes at room temperature.

- **Reaction Initiation:** Initiate the reaction by adding S-adenosyl-L-[methyl-3H]methionine ([3H]-SAM).
- **Incubation:** Incubate the reaction mixture at 37°C for 1 hour.
- **Reaction Termination:** Stop the reaction by adding an excess of cold, non-radiolabeled SAM.
- **Detection:** Transfer the reaction mixture to a streptavidin-coated plate. After washing to remove unincorporated [3H]-SAM, measure the incorporated radioactivity using a scintillation counter.
- **Data Analysis:** Calculate the percent inhibition for each concentration of **LLY-283** and determine the IC50 value using a non-linear regression analysis.

Cellular PRMT5 Target Engagement Assay (Western Blot)

This protocol is based on methods to assess the cellular activity of PRMT5 inhibitors.[13]

- **Cell Culture:** Plate cells (e.g., MCF7) and allow them to adhere overnight.
- **Compound Treatment:** Treat cells with a dose range of **LLY-283** or DMSO for 48-72 hours.
- **Cell Lysis:** Harvest cells and prepare whole-cell lysates using a suitable lysis buffer containing protease and phosphatase inhibitors.
- **Protein Quantification:** Determine the protein concentration of each lysate using a standard method (e.g., BCA assay).
- **Western Blotting:**
 - Separate equal amounts of protein from each sample by SDS-PAGE.
 - Transfer the proteins to a PVDF membrane.
 - Block the membrane with a suitable blocking buffer (e.g., 5% non-fat milk in TBST) for 1 hour at room temperature.

- Incubate the membrane with a primary antibody specific for symmetrically dimethylated arginine (SDMA) on a known PRMT5 substrate (e.g., anti-SmD1/3-Me2s) overnight at 4°C.
- Wash the membrane and incubate with an appropriate HRP-conjugated secondary antibody for 1 hour at room temperature.
- Detect the signal using a chemiluminescent substrate.
- Loading Control: Re-probe the membrane with an antibody against a loading control protein (e.g., β -actin or total SmD3) to ensure equal protein loading.
- Data Analysis: Quantify the band intensities and normalize the SDMA signal to the loading control. Determine the IC50 value for the reduction in substrate methylation.

Visualizations

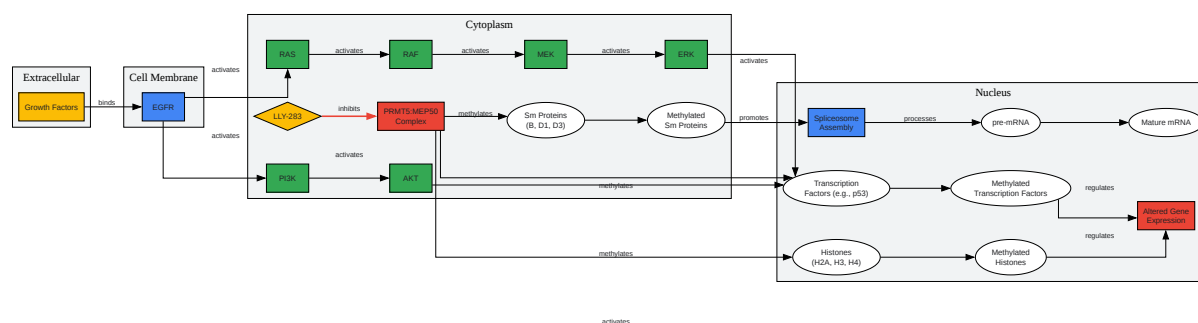

[Click to download full resolution via product page](#)

Caption: PRMT5 signaling pathways and the inhibitory action of **LLY-283**.

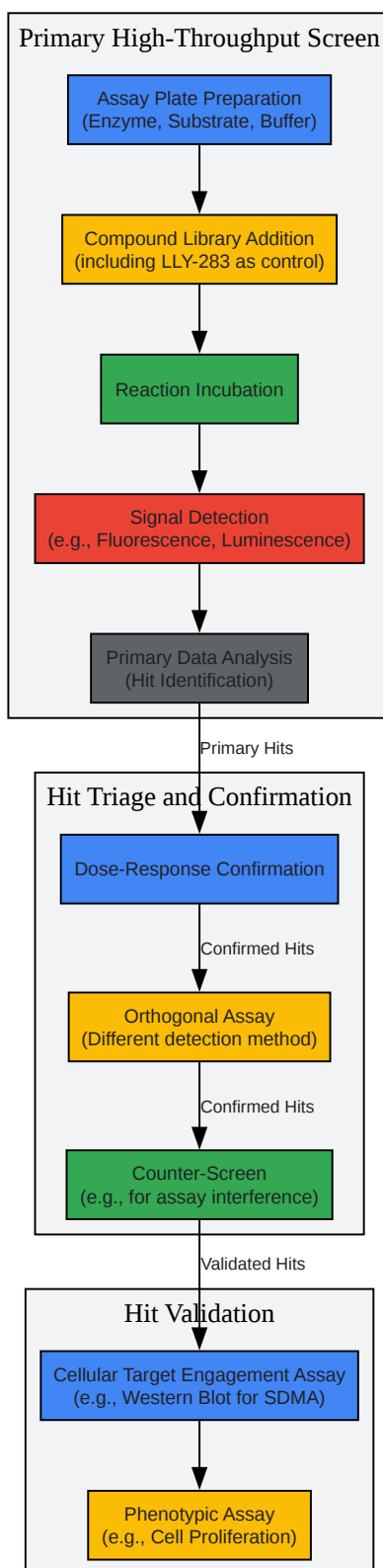

[Click to download full resolution via product page](#)

Caption: A generalized workflow for an **LLY-283** HTS campaign.

Need Custom Synthesis?

BenchChem offers custom synthesis for rare earth carbides and specific isotopic labeling.

Email: info@benchchem.com or [Request Quote Online](#).

References

- [1. selleckchem.com](https://www.selleckchem.com) [selleckchem.com]
- [2. pubs.acs.org](https://pubs.acs.org) [pubs.acs.org]
- [3. LLY-283, a Potent and Selective Inhibitor of Arginine Methyltransferase 5, PRMT5, with Antitumor Activity - PMC](#) [pmc.ncbi.nlm.nih.gov]
- [4. scholars.mssm.edu](https://scholars.mssm.edu) [scholars.mssm.edu]
- [5. LLY-283, a Potent and Selective Inhibitor of Arginine Methyltransferase 5, PRMT5, with Antitumor Activity - PubMed](#) [pubmed.ncbi.nlm.nih.gov]
- [6. researchgate.net](https://www.researchgate.net) [researchgate.net]
- [7. Methyltransferase Inhibitors: Competing with, or Exploiting the Bound Cofactor](#) [mdpi.com]
- [8. The Role of PRMT5 in Immuno-Oncology - PMC](#) [pmc.ncbi.nlm.nih.gov]
- [9. LLY-283 | Structural Genomics Consortium](https://www.thesgc.org) [thesgc.org]
- [10. researchgate.net](https://www.researchgate.net) [researchgate.net]
- [11. mdpi.com](https://www.mdpi.com) [mdpi.com]
- [12. benchchem.com](https://www.benchchem.com) [benchchem.com]
- [13. PRMT5 cellular assay – openlabnotebooks.org](https://openlabnotebooks.org) [openlabnotebooks.org]
- To cite this document: BenchChem. [Technical Support Center: Navigating LLY-283 High-Throughput Screening]. BenchChem, [2026]. [Online PDF]. Available at: [\[https://www.benchchem.com/product/b15583804/docs#technical-support-center-navigating-llly-283-high-throughput-screening\]](https://www.benchchem.com/product/b15583804/docs#technical-support-center-navigating-llly-283-high-throughput-screening)

Disclaimer & Data Validity:

The information provided in this document is for Research Use Only (RUO) and is strictly not intended for diagnostic or therapeutic procedures. While BenchChem strives to provide

accurate protocols, we make no warranties, express or implied, regarding the fitness of this product for every specific experimental setup.

Technical Support: The protocols provided are for reference purposes. Unsure if this reagent suits your experiment?

Need Industrial/Bulk Grade? [Request Custom Synthesis Quote](#)

BenchChem

Our mission is to be the trusted global source of essential and advanced chemicals, empowering scientists and researchers to drive progress in science and industry.

Contact

Address: 3281 E Guasti Rd

Ontario, CA 91761, United States

Phone: (601) 213-4426

Email: info@benchchem.com

[Contact our Ph.D. Support Team for a compatibility check](#)