

# Spectroscopic Properties of 2-Trifluoromethyladenosine: An In-depth Technical Guide

**Author:** BenchChem Technical Support Team. **Date:** April 2026

## Compound of Interest

Compound Name: 2-Trifluoromethyl adenosine

Cat. No.: B15583570

[Get Quote](#)

For Researchers, Scientists, and Drug Development Professionals

This technical guide provides a detailed overview of the spectroscopic properties of 2-Trifluoromethyladenosine, a modified nucleoside of significant interest in biomedical research and drug discovery. The introduction of a trifluoromethyl group at the C2 position of the adenine base dramatically influences its electronic and conformational properties, making spectroscopic analysis a critical tool for its characterization and for studying its interactions with biological targets. This document outlines the expected Ultraviolet-Visible (UV-Vis) and Nuclear Magnetic Resonance (NMR) spectroscopic characteristics of 2-Trifluoromethyladenosine, provides detailed experimental protocols for these analyses, and illustrates relevant biological pathways and experimental workflows.

## Ultraviolet-Visible (UV-Vis) Spectroscopy

The UV-Vis spectrum of 2-Trifluoromethyladenosine is expected to be influenced by the electron-withdrawing nature of the trifluoromethyl group. This modification can cause a shift in the absorption maximum ( $\lambda_{max}$ ) compared to unsubstituted adenosine. Adenosine itself typically exhibits absorption maxima at approximately 206 nm and 258 nm[1]. The introduction

of the CF<sub>3</sub> group at the C2 position is anticipated to cause a slight bathochromic or hypsochromic shift of the main absorption band around 260 nm.

Table 1: Expected UV-Vis Spectroscopic Data for 2-Trifluoromethyladenosine

Compound	$\lambda_{\text{max}}$ (nm)	Molar Absorptivity ( $\epsilon$ ) ( $\text{M}^{-1}\text{cm}^{-1}$ )	Solvent
Adenosine	~259	~15,400	Neutral pH buffer
2-Trifluoromethyladenosine	Anticipated ~260-265	Anticipated ~15,000-16,000	Neutral pH buffer

Note: The values for 2-Trifluoromethyladenosine are predicted based on the known effects of electron-withdrawing groups on the purine chromophore.

## Experimental Protocol for UV-Vis Spectroscopy

A standardized protocol for obtaining the UV-Vis spectrum of 2-Trifluoromethyladenosine is crucial for reproducibility.

Materials:

- 2-Trifluoromethyladenosine sample
- Spectrophotometer-grade solvent (e.g., ethanol, methanol, or a buffered aqueous solution such as 10 mM phosphate buffer, pH 7.4)
- Quartz cuvettes (1 cm path length)
- Calibrated UV-Vis spectrophotometer

Procedure:

- Sample Preparation: Prepare a stock solution of 2-Trifluoromethyladenosine of a known concentration (e.g., 1 mM) in the chosen solvent. From this stock, prepare a dilution to a final concentration that will give an absorbance reading in the optimal range of the

spectrophotometer (typically 0.1 - 1.0 AU). A concentration of approximately 10-50  $\mu\text{M}$  is often suitable.

- **Instrument Setup:** Turn on the spectrophotometer and allow the lamp to warm up for at least 30 minutes to ensure a stable output.
- **Blank Measurement:** Fill a quartz cuvette with the same solvent used to dissolve the sample. Place the cuvette in the spectrophotometer and record a baseline spectrum. This will be subtracted from the sample spectrum to correct for solvent absorbance.
- **Sample Measurement:** Rinse the cuvette with the sample solution before filling it. Place the sample cuvette in the spectrophotometer and record the absorption spectrum over a wavelength range of 200-400 nm.
- **Data Analysis:** Determine the wavelength of maximum absorbance ( $\lambda_{\text{max}}$ ). If the concentration of the sample is known, the molar absorptivity ( $\epsilon$ ) can be calculated using the Beer-Lambert law ( $A = \epsilon cl$ ), where  $A$  is the absorbance at  $\lambda_{\text{max}}$ ,  $c$  is the molar concentration, and  $l$  is the path length of the cuvette (typically 1 cm).

## Nuclear Magnetic Resonance (NMR) Spectroscopy

NMR spectroscopy is an indispensable tool for the structural elucidation of 2-Trifluoromethyladenosine in solution.  $^1\text{H}$ ,  $^{13}\text{C}$ , and  $^{19}\text{F}$  NMR will provide detailed information about the molecular structure, conformation, and electronic environment of the different nuclei. While specific data for 2-Trifluoromethyladenosine is not readily available in the literature, data from the closely related 8-trifluoromethylguanosine can be used to predict the expected chemical shifts[2][3].

Table 2: Predicted NMR Spectroscopic Data for 2-Trifluoromethyladenosine

Nucleus	Predicted Chemical Shift ( $\delta$ , ppm)	Predicted Multiplicity	Predicted Coupling Constants (J, Hz)
<sup>1</sup> H NMR			
H8	~8.2-8.4	s	
H1'	~5.9-6.1	d	J(H1'-H2') $\approx$ 5-6
H2'	~4.6-4.8	t	J(H2'-H1') $\approx$ 5-6, J(H2'-H3') $\approx$ 5-6
H3'	~4.3-4.5	t	J(H3'-H2') $\approx$ 5-6, J(H3'-H4') $\approx$ 3-4
H4'	~4.1-4.3	m	
H5', H5''	~3.7-3.9	m	
NH <sub>2</sub>	~7.3-7.5	br s	
<sup>13</sup> C NMR			
C2	~150-155	q	<sup>1</sup> J(C-F) $\approx$ 270-280
C4	~148-150		
C5	~120-123		
C6	~156-158		
C8	~140-142		
C1'	~88-90		
C2'	~74-76		
C3'	~70-72		
C4'	~85-87		
C5'	~61-63		
<sup>19</sup> F NMR			
2-CF <sub>3</sub>	~ -60 to -65	s	

Note: Predicted chemical shifts are based on data for related trifluoromethylated purine nucleosides and general principles of NMR spectroscopy. Actual values may vary depending on the solvent and other experimental conditions.

## Experimental Protocol for NMR Spectroscopy

### Materials:

- 2-Trifluoromethyladenosine sample (typically 1-5 mg)
- Deuterated solvent (e.g., DMSO-d<sub>6</sub>, D<sub>2</sub>O, or CD<sub>3</sub>OD)
- NMR tubes (5 mm diameter)
- High-field NMR spectrometer (e.g., 400 MHz or higher)

### Procedure:

- **Sample Preparation:** Dissolve the 2-Trifluoromethyladenosine sample in the chosen deuterated solvent (approximately 0.5-0.7 mL). Ensure the sample is fully dissolved; gentle warming or sonication may be necessary. Transfer the solution to an NMR tube.
- **Instrument Setup:** Insert the NMR tube into the spectrometer. The instrument should be tuned to the appropriate frequencies for <sup>1</sup>H, <sup>13</sup>C, and <sup>19</sup>F detection. The magnetic field should be shimmed to achieve high homogeneity, resulting in sharp spectral lines.
- **<sup>1</sup>H NMR Acquisition:**
  - Acquire a standard one-dimensional <sup>1</sup>H spectrum.
  - Typical parameters include a 30-45° pulse angle, a spectral width of ~12-16 ppm, and a relaxation delay of 1-2 seconds.
  - The number of scans will depend on the sample concentration, but 16-64 scans are often sufficient.
- **<sup>13</sup>C NMR Acquisition:**

- Acquire a proton-decoupled  $^{13}\text{C}$  spectrum.
- A larger number of scans (e.g., 1024 or more) will be required due to the lower natural abundance and sensitivity of the  $^{13}\text{C}$  nucleus.
- A spectral width of ~200-220 ppm is typical.
- $^{19}\text{F}$  NMR Acquisition:
  - Acquire a one-dimensional  $^{19}\text{F}$  spectrum. Proton decoupling may be applied to simplify the spectrum.
  - $^{19}\text{F}$  is a highly sensitive nucleus, so fewer scans are generally needed compared to  $^{13}\text{C}$  NMR.
  - A wide spectral width may be necessary depending on the chemical environment of the fluorine atoms. An external reference standard, such as  $\text{CFCl}_3$ , is typically used to reference the chemical shifts to 0 ppm.
- Data Processing and Analysis:
  - Apply a Fourier transform to the acquired free induction decays (FIDs).
  - Phase the resulting spectra and perform baseline correction.
  - Reference the chemical shifts. For  $^1\text{H}$  and  $^{13}\text{C}$  spectra, the residual solvent peak can be used as an internal reference.
  - Integrate the signals in the  $^1\text{H}$  spectrum to determine the relative number of protons.
  - Analyze the chemical shifts, multiplicities, and coupling constants to assign the signals to the respective nuclei in the molecule.

## Signaling Pathways and Experimental Workflows

2-Trifluoromethyladenosine, as an adenosine analog, is expected to interact with adenosine receptors, which are G-protein coupled receptors (GPCRs) involved in numerous physiological processes. Understanding these signaling pathways is crucial for drug development.

## Adenosine Receptor Signaling Pathways

Adenosine receptors are classified into four subtypes: A<sub>1</sub>, A<sub>2A</sub>, A<sub>2B</sub>, and A<sub>3</sub>. The A<sub>1</sub> and A<sub>3</sub> receptors typically couple to inhibitory G-proteins (G<sub>i</sub>/G<sub>o</sub>), while the A<sub>2A</sub> and A<sub>2B</sub> receptors couple to stimulatory G-proteins (G<sub>s</sub>). The binding of an agonist, such as adenosine or its analogs, initiates a signaling cascade.

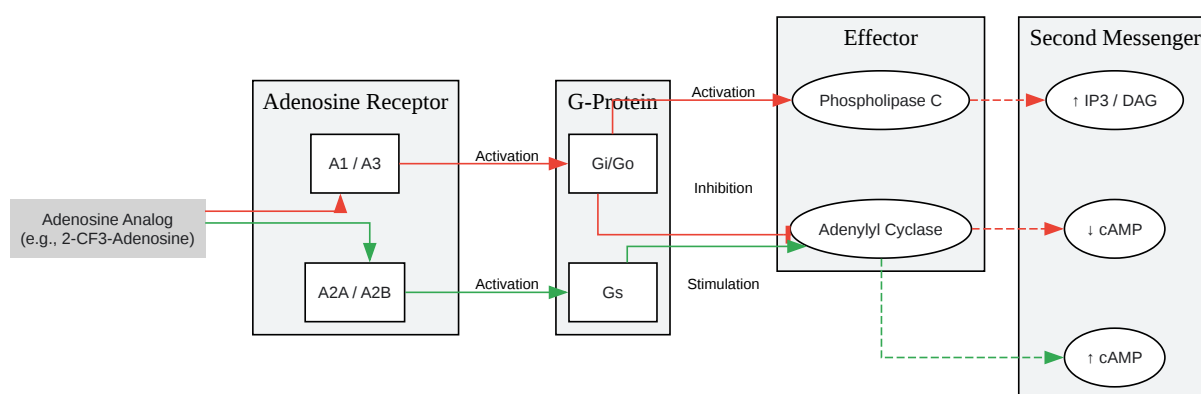

[Click to download full resolution via product page](#)

Caption: General signaling pathways of adenosine receptors.

## Experimental Workflow for Receptor Binding Assay

To determine the affinity of 2-Trifluoromethyladenosine for adenosine receptor subtypes, a competitive radioligand binding assay is a standard method.

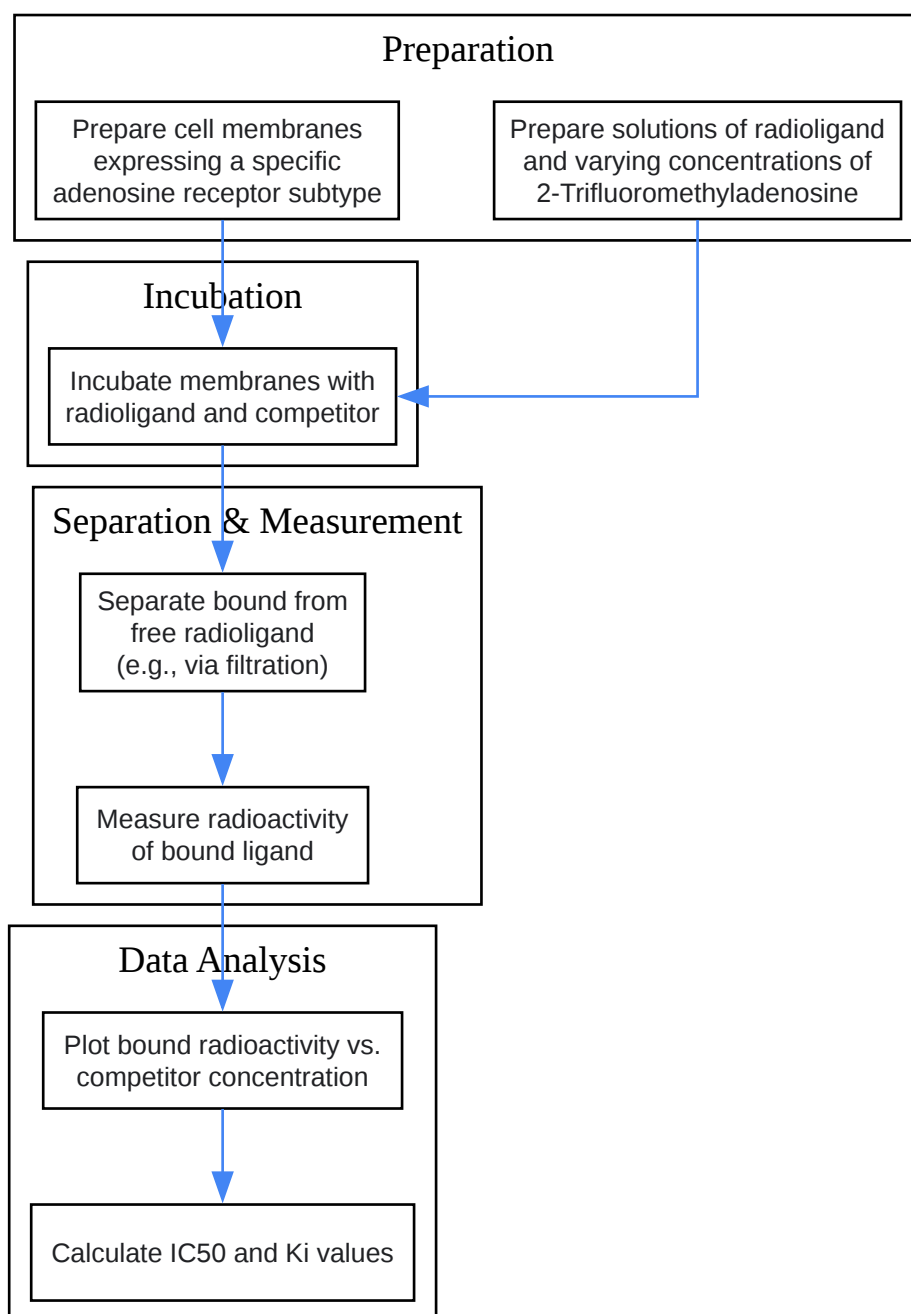

[Click to download full resolution via product page](#)

### Need Custom Synthesis?

BenchChem offers custom synthesis for rare earth carbides and specific isotopic labeling.

Email: [info@benchchem.com](mailto:info@benchchem.com) or [Request Quote Online](#).

## References

- [1. UV-Vis Spectrum of Adenosine | SIELC Technologies \[sielc.com\]](#)
- [2. Synthesis of Trifluoromethylated Purine Ribonucleotides and Their Evaluation as 19F NMR Probes - PMC \[pmc.ncbi.nlm.nih.gov\]](#)
- [3. pubs.acs.org \[pubs.acs.org\]](#)
- To cite this document: BenchChem. [Spectroscopic Properties of 2-Trifluoromethyladenosine: An In-depth Technical Guide]. BenchChem, [2026]. [Online PDF]. Available at: [<https://www.benchchem.com/product/b15583570/docs#spectroscopic-properties-of-2-trifluoromethyladenosine-an-in-depth-technical-guide>]

---

### Disclaimer & Data Validity:

The information provided in this document is for Research Use Only (RUO) and is strictly not intended for diagnostic or therapeutic procedures. While BenchChem strives to provide accurate protocols, we make no warranties, express or implied, regarding the fitness of this product for every specific experimental setup.

**Technical Support:** The protocols provided are for reference purposes. Unsure if this reagent suits your experiment?

**Need Industrial/Bulk Grade?** [Request Custom Synthesis Quote](#)

## BenchChem

Our mission is to be the trusted global source of essential and advanced chemicals, empowering scientists and researchers to drive progress in science and industry.

### Contact

Address: 3281 E Guasti Rd

Ontario, CA 91761, United States

Phone: (601) 213-4426

Email: [info@benchchem.com](mailto:info@benchchem.com)

Contact our Ph.D. Support Team for a compatibility check