

In-Depth Technical Guide: SWOG S2101 (BiCaZO) Study

Author: BenchChem Technical Support Team. **Date:** April 2026

Compound of Interest

Compound Name: S2101
Cat. No.: B15583425

[Get Quote](#)

A Phase II, Biomarker-Stratified Study of Cabozantinib and Nivolumab in Patients with Advanced, Immunotherapy-Refractory Melanoma and Head and Neck Squamous Cell Carcinoma

Study Background

The SWOG **S2101** trial, also known as BiCaZO, is a Phase II clinical study designed to evaluate the efficacy of combining cabozantinib and nivolumab in patients with advanced solid tumors, specifically immunotherapy-refractory melanoma and head and neck squamous cell carcinoma (HNSCC).[1][2] A significant challenge in cancer immunotherapy is overcoming primary or acquired resistance to immune checkpoint inhibitors. The **S2101** study is an immunoMATCH pilot trial that aims to address this challenge by employing a biomarker-stratification strategy to identify patients most likely to benefit from this combination therapy.[1][2]

The central hypothesis of the **S2101** study is that the combination of cabozantinib and nivolumab can induce clinically meaningful responses in patients who have progressed on prior anti-PD-1/L1 therapy. Furthermore, the study seeks to determine if the response to this combination therapy is associated with pre-defined tumor biomarkers: Tumor Mutational

Burden (TMB) and a Tumor Inflammation Signature (TIS), also known as a T-cell inflamed gene expression profile (GEP).[1][2]

The study is divided into two stages. In Stage I, patients are enrolled and begin treatment while their tumor tissue is retrospectively analyzed for the biomarker status. In Stage II, patients are prospectively assigned to one of four biomarker-defined cohorts before the initiation of treatment.[3] One of the key feasibility endpoints of the study is to achieve a turnaround time of 21 days or less for the molecular characterization of the tumor biopsies.[1]

Scientific Premise

The scientific rationale for the **S2101** study is grounded in the potential for synergistic anti-tumor activity when combining a multi-targeted tyrosine kinase inhibitor (TKI) with an immune checkpoint inhibitor.

Nivolumab is a fully human IgG4 monoclonal antibody that acts as an immune checkpoint inhibitor by blocking the interaction between the programmed death-1 (PD-1) receptor on T-cells and its ligands, PD-L1 and PD-L2, which are often expressed on tumor cells. By disrupting this inhibitory signal, nivolumab restores the ability of the immune system, particularly cytotoxic T-cells, to recognize and eliminate cancer cells.

Cabozantinib is a potent small-molecule inhibitor of multiple receptor tyrosine kinases, including MET, VEGFR2, and AXL. These kinases are involved in various aspects of tumor progression, including proliferation, invasion, metastasis, and angiogenesis. Beyond its direct anti-tumor effects, cabozantinib has been shown to modulate the tumor microenvironment in ways that may enhance the efficacy of immunotherapy. Specifically, cabozantinib can:

- Reduce immunosuppressive cell populations: By inhibiting key signaling pathways, cabozantinib may decrease the number and function of regulatory T-cells (Tregs) and myeloid-derived suppressor cells (MDSCs) within the tumor microenvironment.
- Increase pro-inflammatory cytokines: Cabozantinib may promote a more inflamed tumor microenvironment, which is generally more responsive to immune checkpoint inhibition.
- Enhance T-cell infiltration: By targeting VEGFR, cabozantinib can normalize the tumor vasculature, which may facilitate the infiltration of effector T-cells into the tumor.

The combination of cabozantinib and nivolumab is therefore hypothesized to have a dual mechanism of action: direct inhibition of tumor growth and angiogenesis by cabozantinib, coupled with a restored anti-tumor immune response enabled by nivolumab, which is further potentiated by the immunomodulatory effects of cabozantinib on the tumor microenvironment.

The stratification of patients based on TMB and TIS is a key component of the study's scientific premise.

- **Tumor Mutational Burden (TMB):** A high TMB is thought to lead to the generation of a greater number of neoantigens, which can be recognized by the immune system as foreign, thereby making the tumor more immunogenic and potentially more susceptible to immunotherapy.
- **Tumor Inflammation Signature (TIS):** This 18-gene signature reflects a pre-existing but suppressed adaptive immune response within the tumor microenvironment. A high TIS score indicates the presence of immune cells and interferon-gamma signaling, suggesting that the tumor has been recognized by the immune system but is evading destruction via inhibitory mechanisms like the PD-1/PD-L1 pathway.

By stratifying patients into four cohorts based on high or low TMB and TIS, the **S2101** study aims to prospectively evaluate the predictive value of these biomarkers for the combination of cabozantinib and nivolumab.

Quantitative Data Summary

Study Endpoints

Endpoint Type	Endpoint	Metric(s)
Primary	Feasibility of molecular characterization for patient stratification	Proportion of patients with a turnaround time of ≤ 21 days for biopsy results (Stage I).[1]
Efficacy of cabozantinib plus nivolumab	Overall Response Rate (ORR), defined as confirmed and unconfirmed partial and complete responses.[1]	
Secondary	Difference in efficacy between biomarker subgroups	Comparison of ORR in each disease cohort between the four tumor biomarker subgroups.[1]
Safety and tolerability	Incidence and severity of adverse events.	
Disease Control	Disease Control Rate (DCR). [1]	
Survival	Progression-Free Survival (PFS) and Overall Survival (OS).[1]	
Assay Performance	Proportion of patients with assay failure and time from tissue collection to molecular group determination (Stage I). [1]	

Patient Population and Stratification

Characteristic	Details
Disease Cohorts	- Histologically confirmed unresectable or metastatic melanoma (Stage III or IV) that is non-uveal.[4] - Histologically confirmed recurrent or metastatic squamous cell carcinoma of the head and neck (HNSCC) of the oral cavity, oropharynx, hypopharynx, or larynx.[4]
Prior Treatment	Documented disease progression within 12 weeks after the last dose of a PD-1/L1 checkpoint inhibitor-based therapy (minimum of 6 weeks of treatment).[4]
Performance Status	Zubrod Performance Status of 0 or 1.[4]
Biomarker Stratification	Patients are stratified into one of four cohorts based on tumor biomarker status:[3] - TMB-high / TIS-high - TMB-high / TIS-low - TMB-low / TIS-high - TMB-low / TIS-low

Experimental Protocols

Tumor Mutational Burden (TMB) Assessment

The SWOG **S2101** study protocol specifies that TMB will be assessed using a validated next-generation sequencing (NGS) assay. While the specific assay is not publicly disclosed in all trial documents, the FoundationOne®CDx assay is a likely candidate as it is an FDA-approved comprehensive genomic profiling test that includes TMB measurement and is widely used in clinical trials.

Methodology (based on FoundationOne®CDx):

- DNA Extraction: DNA is isolated from formalin-fixed, paraffin-embedded (FFPE) tumor tissue specimens.
- Library Preparation: DNA is used to prepare an NGS library using targeted high-throughput hybridization-based capture technology. The FoundationOne®CDx assay targets 324 genes.

- Sequencing: The prepared library is sequenced using a next-generation sequencer.
- Data Analysis:
 - Somatic alterations, including substitutions, insertions, and deletions, are identified.
 - The TMB is calculated by counting all synonymous and non-synonymous variants present at an allele frequency of 5% or greater, after filtering for germline variants.
 - The total number of mutations is reported as mutations per megabase (mut/Mb).[5]

Tumor Inflammation Signature (TIS) Assessment

The Tumor Inflammation Signature, also referred to as a T-cell inflamed gene expression profile (GEP), is assessed using a targeted gene expression profiling assay. The NanoString nCounter® platform is a likely technology for this assessment due to its robustness with FFPE samples and its use in the development and validation of the 18-gene TIS.

Methodology (based on NanoString nCounter®):

- RNA Extraction: RNA is extracted from FFPE tumor tissue sections.
- Hybridization: The extracted RNA is mixed with a reporter and capture probe set specific to the 18 genes in the TIS panel. The nCounter® PanCancer IO 360™ Panel includes the TIS gene signature.[6]
- Sample Processing: The hybridized samples are processed on the nCounter® Prep Station for purification and immobilization of the probe-target complexes.
- Data Acquisition: The processed samples are read by the nCounter® Digital Analyzer, which counts the individual fluorescent barcodes corresponding to each of the 18 target genes.
- Data Analysis:
 - The raw gene expression counts are normalized.
 - The normalized expression levels of the 18 genes are used to calculate a TIS score.

- The TIS score is used to classify tumors as "hot" (inflamed) or "cold" (non-inflamed).

The 18 genes in the TIS are associated with four key areas of immune biology: IFN- γ -responsive genes related to antigen presentation, chemokine expression, cytotoxic activity, and adaptive immune resistance.[7]

Mandatory Visualizations

Signaling Pathways

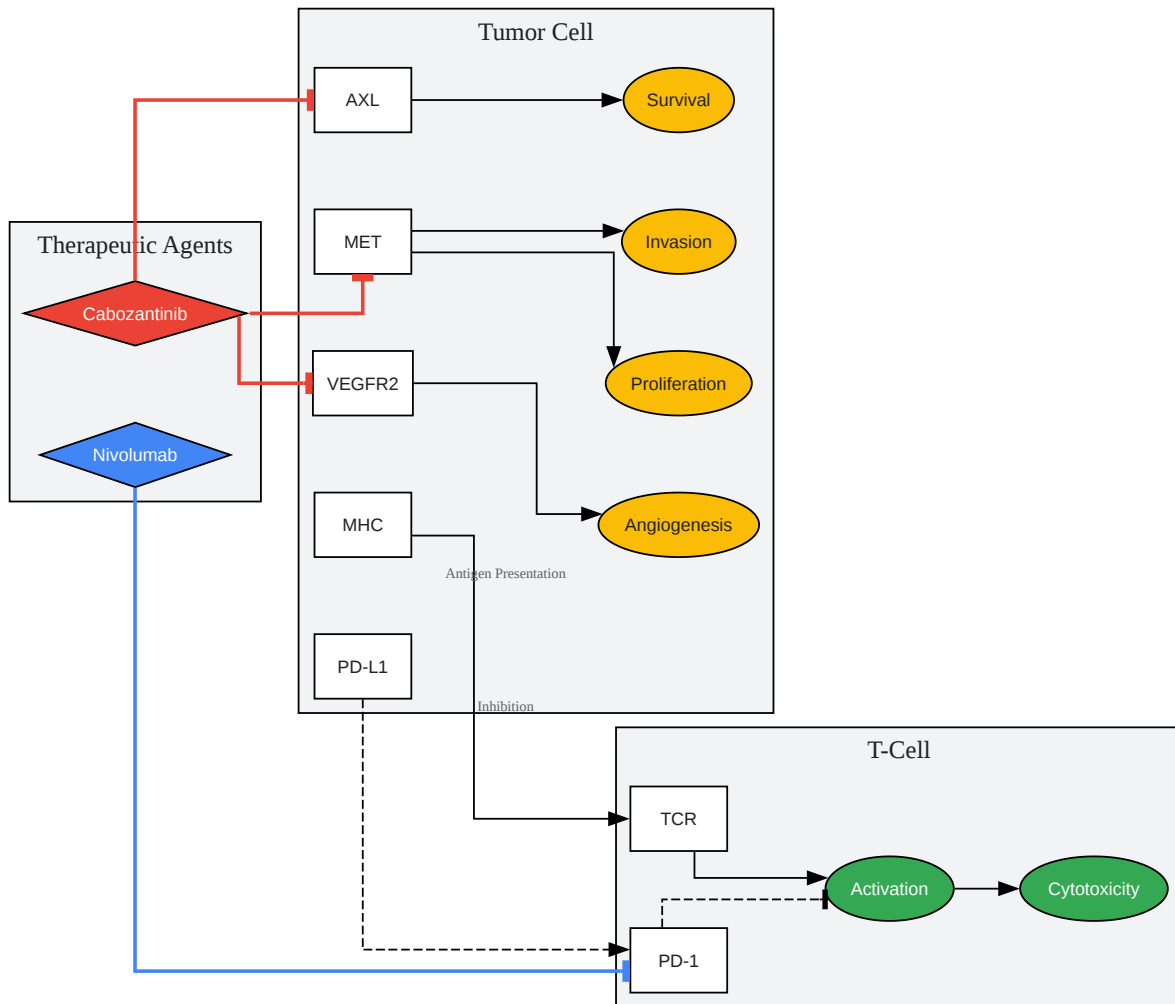

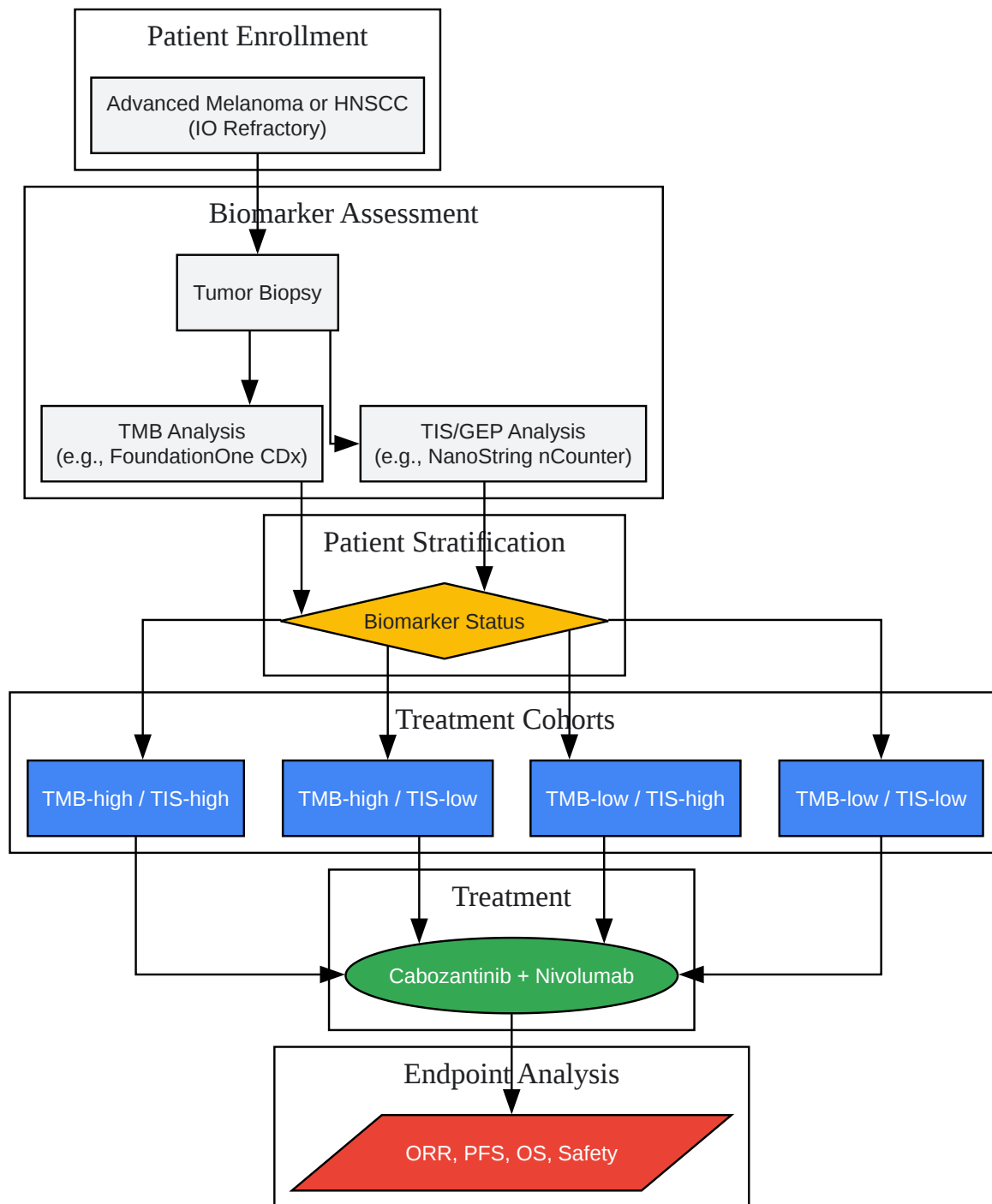

[Click to download full resolution via product page](#)

Need Custom Synthesis?

BenchChem offers custom synthesis for rare earth carbides and specific isotopic labeling.

Email: info@benchchem.com or [Request Quote Online](#).

References

- [1. SWOG, S2101, PhII, open label, Cabozantinib + Nivolumab, Melanoma or HNSCC \[clinicaltrials.cedars-sinai.edu\]](#)
- [2. prohealthcare.org \[prohealthcare.org\]](#)
- [3. ozarkscancerresearch.org \[ozarkscancerresearch.org\]](#)
- [4. S2101 | SWOG \[swog.org\]](#)
- [5. assets.ctfassets.net \[assets.ctfassets.net\]](#)
- [6. nanostring.com \[nanostring.com\]](#)
- [7. nanostring.com \[nanostring.com\]](#)
- To cite this document: BenchChem. [In-Depth Technical Guide: SWOG S2101 (BiCaZO) Study]. BenchChem, [2026]. [Online PDF]. Available at: [\[https://www.benchchem.com/product/b15583425/docs#in-depth-technical-guide-swog-s2101-bicazo-study\]](https://www.benchchem.com/product/b15583425/docs#in-depth-technical-guide-swog-s2101-bicazo-study)

Disclaimer & Data Validity:

The information provided in this document is for Research Use Only (RUO) and is strictly not intended for diagnostic or therapeutic procedures. While BenchChem strives to provide accurate protocols, we make no warranties, express or implied, regarding the fitness of this product for every specific experimental setup.

Technical Support: The protocols provided are for reference purposes. Unsure if this reagent suits your experiment?

Need Industrial/Bulk Grade? [Request Custom Synthesis Quote](#)

BenchChem

Our mission is to be the trusted global source of essential and advanced chemicals, empowering scientists and researchers to drive progress in science and industry.

Contact

Address: 3281 E Guasti Rd

Ontario, CA 91761, United States

Phone: (601) 213-4426

Email: info@benchchem.com

[Contact our Ph.D. Support Team for a compatibility check](#)