

Carm1-IN-6 Technical Support Center: Troubleshooting and FAQs

Author: BenchChem Technical Support Team. **Date:** April 2026

Compound of Interest

Compound Name: *Carm1-IN-6*

Cat. No.: *B15583295*

[Get Quote](#)

For Researchers, Scientists, and Drug Development Professionals

This technical support center provides essential information regarding the potential off-target effects of **Carm1-IN-6** (also known as iCARM1), a selective inhibitor of Coactivator-Associated Arginine Methyltransferase 1 (CARM1). This resource is designed to assist researchers in designing experiments, interpreting results, and troubleshooting potential issues related to inhibitor specificity.

Frequently Asked Questions (FAQs)

Q1: What is **Carm1-IN-6** and what is its reported potency?

Carm1-IN-6 (iCARM1) is a selective inhibitor of CARM1. It has a reported IC₅₀ value of 12.3 μM for CARM1 and a binding affinity (K_d) of 0.67 μM.^{[1][2]}

Q2: What is the known selectivity of **Carm1-IN-6** against other methyltransferases?

Carm1-IN-6 is reported to be a specific inhibitor of CARM1. One study has shown that it specifically inhibits CARM1-mediated histone methylation, including H3R17me2a and H3R26me2a, in a dose-dependent manner. The same study suggests it does not affect other

histone arginine methylation markers mediated by other members of the Protein Arginine Methyltransferase (PRMT) family.[3][4][5] However, comprehensive quantitative data from broad selectivity panels against other PRMTs or kinases are not yet publicly available.

Q3: How does the specificity of **Carm1-IN-6** compare to other known CARM1 inhibitors?

The discovering publication reports that **Carm1-IN-6** (iCARM1) demonstrates better specificity and activity toward CARM1 in comparison to the well-characterized CARM1 inhibitors EZM2302 and TP-064.[3][4][5]

Q4: What are the potential consequences of off-target effects when using a CARM1 inhibitor?

Off-target effects can lead to misinterpretation of experimental results, attributing a biological phenomenon to CARM1 inhibition when it may be caused by the modulation of another protein. Given the high degree of homology within the PRMT family, cross-reactivity is a potential concern. For instance, PRMT6 has been shown to have some overlapping substrate specificity with CARM1, as both can methylate Histone H3 at Arginine 17 (H3R17). Therefore, using a highly selective inhibitor is crucial for accurately defining the biological functions of CARM1.

Troubleshooting Guide

Issue	Potential Cause	Recommended Action
Unexpected Phenotype Observed	The observed effect may be due to inhibition of an unknown off-target protein.	<ol style="list-style-type: none">1. Validate with a structurally distinct CARM1 inhibitor: Use another well-characterized CARM1 inhibitor (e.g., EZM2302, TP-064) to see if the phenotype is recapitulated.2. Perform a rescue experiment: If possible, overexpress a resistant mutant of CARM1 to see if it reverses the observed phenotype.3. Conduct target engagement assays: Confirm that Carm1-IN-6 is engaging CARM1 in your experimental system at the concentrations used.
Inconsistent Results Between Experiments	Variability in experimental conditions can affect inhibitor potency and selectivity.	<ol style="list-style-type: none">1. Ensure consistent inhibitor concentration and treatment duration.2. Monitor cell health and density: Cellular stress can alter signaling pathways and drug responses.3. Verify the purity and stability of your Carm1-IN-6 stock solution.
No Effect Observed at Expected Concentrations	The inhibitor may not be active in your specific cellular context or experimental setup.	<ol style="list-style-type: none">1. Confirm CARM1 expression in your model system.2. Perform a dose-response curve to determine the optimal concentration for your experiment.3. Assess cellular uptake of the inhibitor if possible.
Difficulty Interpreting Downstream Effects	CARM1 has a wide range of substrates involved in various	<ol style="list-style-type: none">1. Consult the literature for known CARM1 substrates and

cellular processes, making it challenging to pinpoint the direct cause of an observed phenotype.

signaling pathways. 2. Use pathway analysis tools to interpret transcriptomic or proteomic data. 3. Investigate the methylation status of known CARM1 substrates (e.g., H3R17, PABP1) to confirm on-target activity.

Quantitative Data Summary

While a comprehensive quantitative selectivity panel for **Carm1-IN-6** is not available in the public domain, the following table summarizes the available potency data.

Target	Inhibitor	IC50	Binding Affinity (Kd)	Reference
CARM1	Carm1-IN-6 (iCARM1)	12.3 μ M	0.67 μ M	[1][2]

Signaling Pathway and Experimental Workflow Diagrams

To aid in experimental design and data interpretation, the following diagrams illustrate the CARM1 signaling pathway and a general workflow for assessing inhibitor off-target effects.

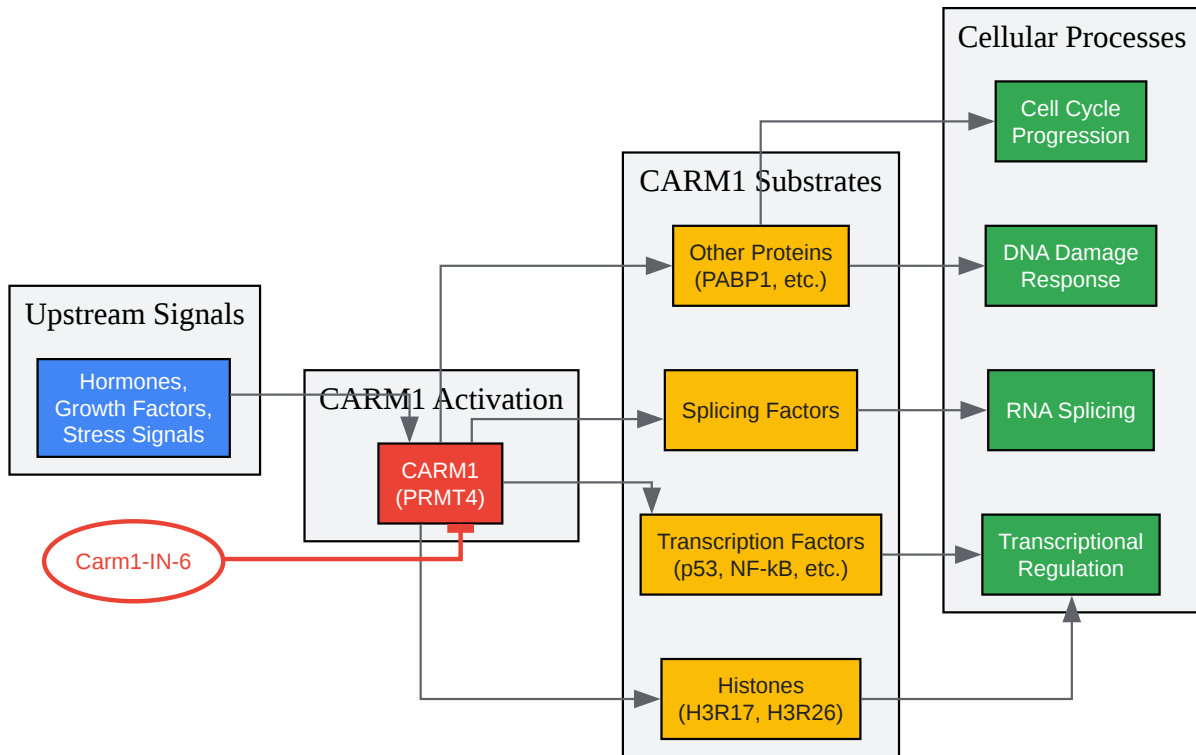

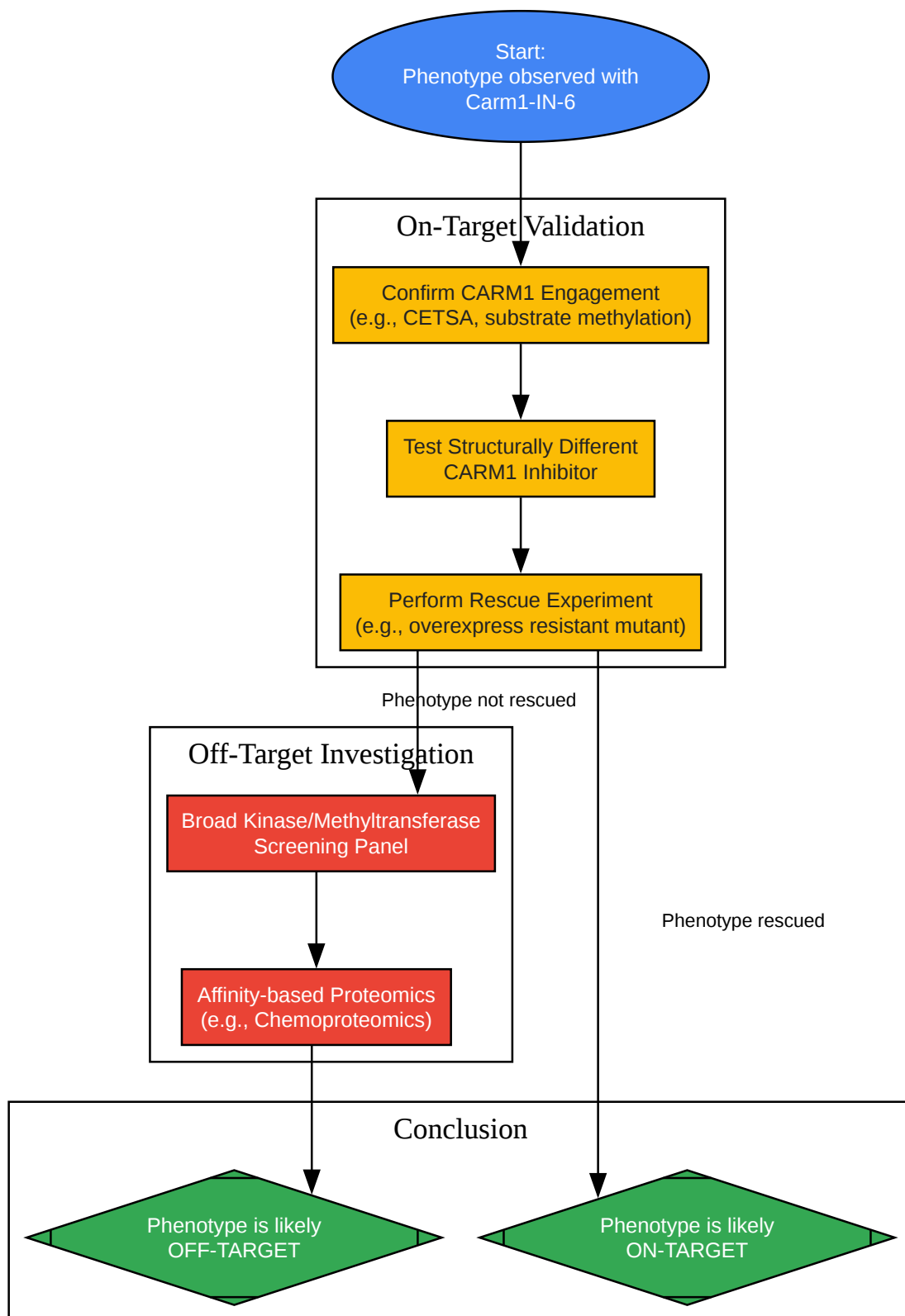

[Click to download full resolution via product page](#)

Need Custom Synthesis?

BenchChem offers custom synthesis for rare earth carbides and specific isotopic labeling.

Email: info@benchchem.com or [Request Quote Online](#).

References

- [1. medchemexpress.com \[medchemexpress.com\]](https://www.medchemexpress.com)
- [2. medchemexpress.com \[medchemexpress.com\]](https://www.medchemexpress.com)
- [3. pubs.acs.org \[pubs.acs.org\]](https://pubs.acs.org)
- [4. researchgate.net \[researchgate.net\]](https://www.researchgate.net)
- [5. A CARM1 Inhibitor Potently Suppresses Breast Cancer Both In Vitro and In Vivo - PMC \[pmc.ncbi.nlm.nih.gov\]](#)
- To cite this document: BenchChem. [Carm1-IN-6 Technical Support Center: Troubleshooting and FAQs]. BenchChem, [2026]. [Online PDF]. Available at: [\[https://www.benchchem.com/product/b15583295/docs#carm1-in-6-technical-support-center-troubleshooting-and-faqs\]](https://www.benchchem.com/product/b15583295/docs#carm1-in-6-technical-support-center-troubleshooting-and-faqs)

Disclaimer & Data Validity:

The information provided in this document is for Research Use Only (RUO) and is strictly not intended for diagnostic or therapeutic procedures. While BenchChem strives to provide accurate protocols, we make no warranties, express or implied, regarding the fitness of this product for every specific experimental setup.

Technical Support: The protocols provided are for reference purposes. Unsure if this reagent suits your experiment?

Need Industrial/Bulk Grade? [Request Custom Synthesis Quote](#)

BenchChem

Our mission is to be the trusted global source of essential and advanced chemicals, empowering scientists and researchers to drive progress in science and industry.

Contact

Address: 3281 E Guasti Rd

Ontario, CA 91761, United States

Phone: (601) 213-4426

Email: info@benchchem.com

[Contact our Ph.D. Support Team for a compatibility check](#)