

Application of GSK591 in High-Throughput Screening: A Guide for Researchers

Author: BenchChem Technical Support Team. **Date:** April 2026

Compound of Interest

Compound Name: Gsk591
Cat. No.: B15583472

[Get Quote](#)

For Researchers, Scientists, and Drug Development Professionals

This document provides detailed application notes and protocols for utilizing **GSK591**, a potent and selective inhibitor of Protein Arginine Methyltransferase 5 (PRMT5), in high-throughput screening (HTS) assays. These guidelines are intended to assist in the identification and characterization of novel PRMT5 inhibitors for drug discovery and basic research.

Introduction to GSK591 and PRMT5

Protein Arginine Methyltransferase 5 (PRMT5) is a critical enzyme that catalyzes the symmetric dimethylation of arginine residues on both histone and non-histone proteins.[1] This post-translational modification plays a crucial role in the regulation of numerous cellular processes, including gene transcription, RNA splicing, signal transduction, and the DNA damage response.[2][3] Dysregulation of PRMT5 activity has been implicated in various cancers, making it an attractive therapeutic target.[2][3]

GSK591 is a highly potent and selective small molecule inhibitor of PRMT5. It serves as an invaluable chemical probe for elucidating the biological functions of PRMT5 and as a reference compound in high-throughput screening campaigns aimed at discovering novel PRMT5 inhibitors.

Application Notes

GSK591 is amenable to a variety of biochemical and cell-based high-throughput screening formats. The choice of assay depends on the specific research question, available resources, and the desired screening outcome (e.g., identification of direct enzyme inhibitors versus compounds that modulate PRMT5 activity in a cellular context).

Biochemical Assays: These assays directly measure the enzymatic activity of purified PRMT5. They are ideal for identifying compounds that bind to and inhibit the enzyme directly.

- **AlphaLISA (Amplified Luminescent Proximity Homogeneous Assay):** This bead-based immunoassay is a highly sensitive and robust method for HTS. It detects the specific methylation of a biotinylated substrate by PRMT5.^[4] The assay is homogeneous, requiring no wash steps, which simplifies automation.
- **Fluorescence Polarization (FP):** This technique measures changes in the polarization of fluorescent light emitted by a small, labeled molecule (tracer) as it binds to a larger protein. In a competitive binding format, inhibitors displace the fluorescent tracer from the PRMT5 active site, leading to a decrease in fluorescence polarization.^[1]

Cell-Based Assays: These assays measure the effect of compounds on PRMT5 activity within a cellular environment, providing insights into cell permeability, off-target effects, and downstream functional consequences.

- **Cellular Symmetric Dimethylarginine (SDMA) Assay:** This assay quantifies the levels of SDMA, a direct product of PRMT5 activity, in whole-cell lysates. A reduction in SDMA levels indicates target engagement and inhibition of PRMT5 in a cellular context.
- **Cell Proliferation/Viability Assays:** As PRMT5 is often essential for the proliferation of cancer cells, assays that measure cell viability (e.g., using CellTiter-Glo® or resazurin) can be used to screen for compounds that inhibit PRMT5-dependent cell growth.

Data Presentation

The following tables summarize representative quantitative data for **GSK591** in various assays.

Table 1: In Vitro and Cellular Potency of **GSK591**

Assay Type	Parameter	Value	Cell Line (if applicable)	Reference
Biochemical (HTRF)	IC ₅₀	11 nM	N/A	[1]
Cellular (SDMA)	EC ₅₀	56 nM	Z-138	[1]

Table 2: Representative High-Throughput Screening Data for **GSK591** (AlphaLISA Assay)

GSK591 Conc. (nM)	Raw AlphaLISA Signal (Counts)	% Inhibition
0 (No Inhibitor)	250,000	0
1	225,000	10
5	175,000	30
10	125,000	50
50	50,000	80
100	25,000	90
1000	5,000	98
No Enzyme Control	2,000	99.2

Experimental Protocols

Biochemical High-Throughput Screening using AlphaLISA

This protocol is designed for a 384-well plate format and is based on the principle of detecting the symmetric dimethylation of a biotinylated histone H4 peptide substrate by PRMT5.

Materials:

- Recombinant human PRMT5/MEP50 complex

- Biotinylated Histone H4 (1-21) peptide substrate
- S-adenosyl-L-methionine (SAM)
- **GSK591** (or other test compounds)
- AlphaLISA anti-H4R3me2s Acceptor beads
- Streptavidin-coated Donor beads
- AlphaLISA Assay Buffer (e.g., 50 mM Tris-HCl pH 8.0, 5 mM DTT, 0.01% Tween-20)
- 384-well white opaque microplates (e.g., OptiPlate™-384)
- Plate reader capable of AlphaLISA detection (e.g., EnVision® Multilabel Reader)

Protocol:

- Compound Preparation: Prepare serial dilutions of **GSK591** and test compounds in DMSO. The final DMSO concentration in the assay should be kept below 1%.
- Reagent Preparation:
 - Enzyme Solution: Dilute the PRMT5/MEP50 complex in AlphaLISA Assay Buffer to the desired final concentration (e.g., 1-5 nM).
 - Substrate/SAM Mix: Prepare a 2X working solution of the biotinylated histone H4 peptide and SAM in AlphaLISA Assay Buffer. Final concentrations in the assay are typically in the range of 20-50 nM for the peptide and 1-10 μ M for SAM.
 - Acceptor Bead Suspension: Dilute the anti-H4R3me2s Acceptor beads in AlphaLISA Assay Buffer to the recommended concentration (e.g., 20 μ g/mL).
 - Donor Bead Suspension: Dilute the Streptavidin-coated Donor beads in AlphaLISA Assay Buffer to the recommended concentration (e.g., 20 μ g/mL).
- Assay Procedure:
 - a. Add 2.5 μ L of the Substrate/SAM Mix to each well of the 384-well plate.
 - b. Add 0.5 μ L of compound solution (or DMSO for controls) to the appropriate wells. c.

Initiate the enzymatic reaction by adding 2.0 μL of the Enzyme Solution to each well. d. Incubate the plate at room temperature for 60-120 minutes. e. Stop the reaction and detect the product by adding 5 μL of the Acceptor Bead Suspension. f. Incubate for 60 minutes at room temperature in the dark. g. Add 5 μL of the Donor Bead Suspension. h. Incubate for another 60 minutes at room temperature in the dark. i. Read the plate on an AlphaLISA-compatible plate reader.

Biochemical High-Throughput Screening using Fluorescence Polarization

This protocol describes a competitive binding assay where the displacement of a fluorescently labeled tracer from PRMT5 by an inhibitor is measured.

Materials:

- Recombinant human PRMT5/MEP50 complex
- Fluorescently labeled tracer (e.g., a fluorescent analog of S-adenosyl-L-homocysteine (SAH) or a fluorescently labeled substrate peptide)
- **GSK591** (or other test compounds)
- FP Assay Buffer (e.g., 50 mM HEPES pH 7.5, 150 mM NaCl, 1 mM DTT, 0.01% BSA)
- 384-well black, low-binding microplates
- Plate reader with fluorescence polarization capabilities

Protocol:

- Compound Preparation: Prepare serial dilutions of **GSK591** and test compounds in DMSO. The final DMSO concentration should be kept low.
- Reagent Preparation:
 - Enzyme Solution: Dilute the PRMT5/MEP50 complex in FP Assay Buffer. The optimal concentration should be determined experimentally by titration.

- Tracer Solution: Dilute the fluorescent tracer in FP Assay Buffer to a final concentration that gives a stable and robust FP signal (typically in the low nanomolar range).
- Assay Procedure: a. Add 5 μL of the Enzyme Solution to each well of the 384-well plate. b. Add 0.5 μL of compound solution (or DMSO for controls). c. Incubate for 15-30 minutes at room temperature to allow for compound binding. d. Add 5 μL of the Tracer Solution to all wells. e. Incubate for 30-60 minutes at room temperature, protected from light, to reach binding equilibrium. f. Measure the fluorescence polarization on a suitable plate reader.

Visualizations

Signaling Pathways and Experimental Workflows

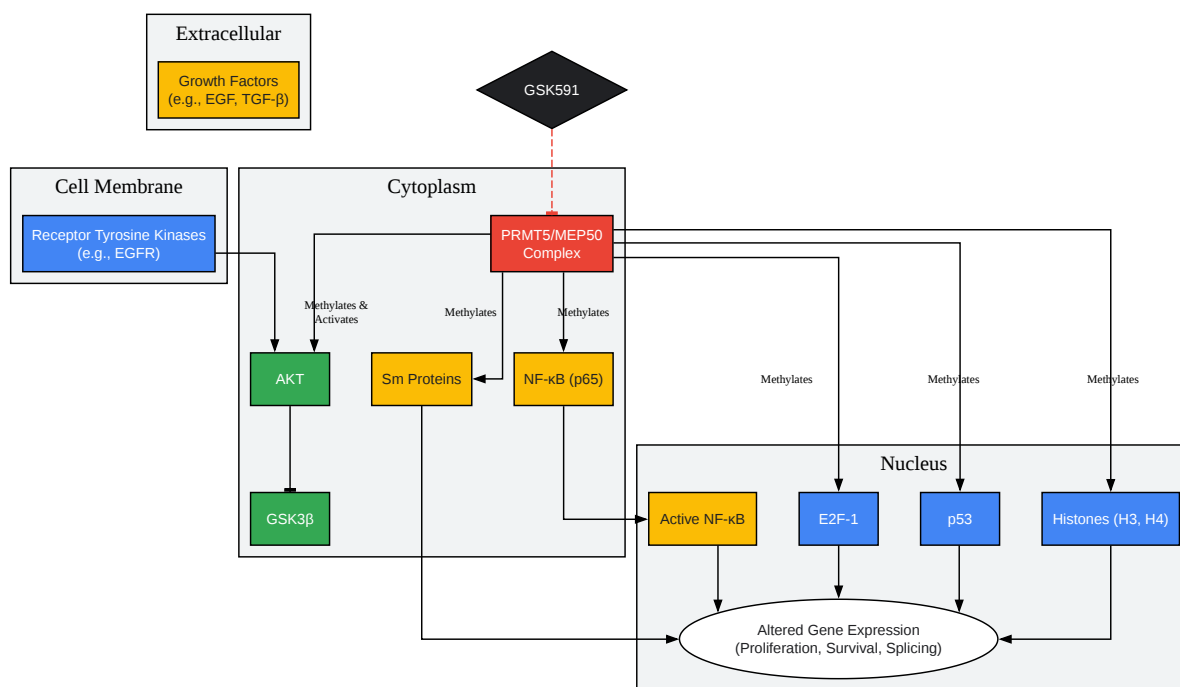

[Click to download full resolution via product page](#)

Caption: PRMT5 signaling pathways and the inhibitory action of **GSK591**.

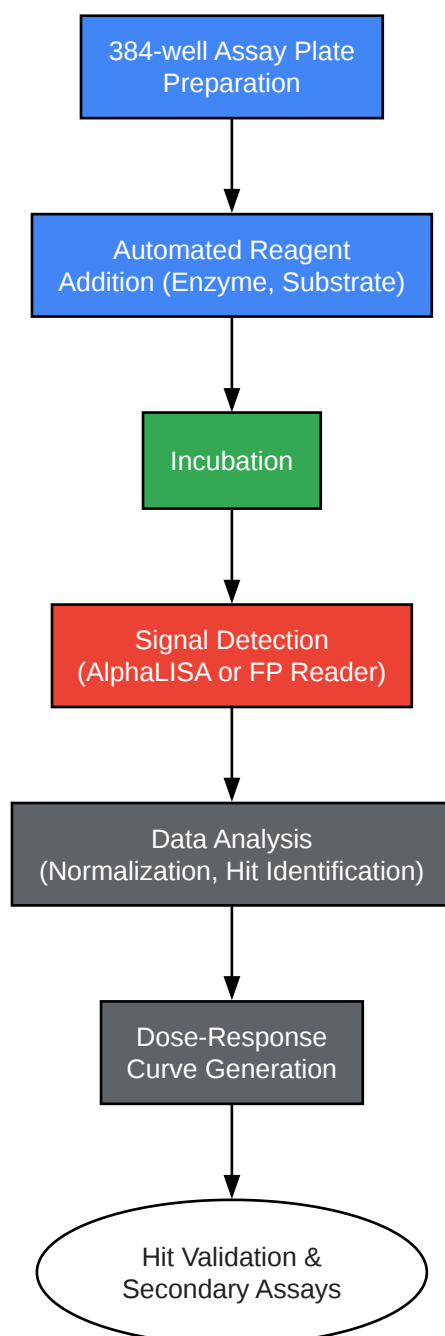

[Click to download full resolution via product page](#)

Caption: General experimental workflow for high-throughput screening.

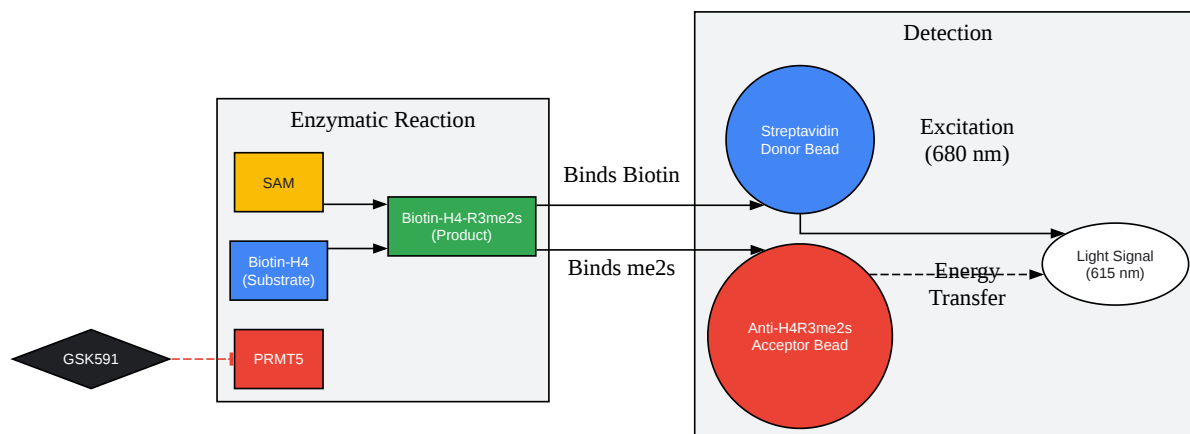

[Click to download full resolution via product page](#)

Caption: Principle of the PRMT5 AlphaLISA high-throughput assay.

Need Custom Synthesis?

BenchChem offers custom synthesis for rare earth carbides and specific isotopic labeling.

Email: info@benchchem.com or [Request Quote Online](#).

References

- 1. Fluorescence Polarization Assays in Small Molecule Screening - PMC [pmc.ncbi.nlm.nih.gov]
- 2. PRMT5 function and targeting in cancer [cell-stress.com]
- 3. Protein arginine methyltransferase 5 (PRMT5) dysregulation in cancer - PMC [pmc.ncbi.nlm.nih.gov]
- 4. Development of AlphaLISA high throughput technique to screen for small molecule inhibitors targeting protein arginine methyltransferases - PMC [pmc.ncbi.nlm.nih.gov]

- To cite this document: BenchChem. [Application of GSK591 in High-Throughput Screening: A Guide for Researchers]. BenchChem, [2026]. [Online PDF]. Available at: [<https://www.benchchem.com/product/b15583472/docs#application-of-gsk591-in-high-throughput-screening-a-guide-for-researchers>]

Disclaimer & Data Validity:

The information provided in this document is for Research Use Only (RUO) and is strictly not intended for diagnostic or therapeutic procedures. While BenchChem strives to provide accurate protocols, we make no warranties, express or implied, regarding the fitness of this product for every specific experimental setup.

Technical Support: The protocols provided are for reference purposes. Unsure if this reagent suits your experiment?

Need Industrial/Bulk Grade? [Request Custom Synthesis Quote](#)

BenchChem

Our mission is to be the trusted global source of essential and advanced chemicals, empowering scientists and researchers to drive progress in science and industry.

Contact

Address: 3281 E Guasti Rd
Ontario, CA 91761, United States
Phone: (601) 213-4426
Email: info@benchchem.com

[Contact our Ph.D. Support Team for a compatibility check](#)