

A Comparative Analysis of FeTMPyP's Anti-Inflammatory Properties

Author: BenchChem Technical Support Team. **Date:** April 2026

Compound of Interest

Compound Name: FeTMPyP
Cat. No.: B15583630

[Get Quote](#)

For Researchers, Scientists, and Drug Development Professionals

This guide provides a comprehensive cross-validation of the anti-inflammatory properties of the peroxynitrite decomposition catalyst, **FeTMPyP**. Its performance is objectively compared with two other well-established anti-inflammatory agents: the natural polyphenol Resveratrol and the non-steroidal anti-inflammatory drug (NSAID) Celecoxib. This analysis is supported by experimental data from in vivo and in vitro studies, with a focus on quantitative comparisons and mechanistic insights.

Mechanism of Action: A Comparative Overview

FeTMPyP exerts its anti-inflammatory effects primarily by catalyzing the decomposition of peroxynitrite, a potent cytotoxic oxidant formed from the reaction of nitric oxide and superoxide radicals. By neutralizing peroxynitrite, **FeTMPyP** mitigates oxidative and nitrosative stress, which are key drivers of inflammation. This action leads to the downstream inhibition of the NF- κ B signaling pathway and a reduction in the expression of pro-inflammatory cytokines and enzymes such as TNF- α , IL-6, and inducible nitric oxide synthase (iNOS).^{[1][2]}

Resveratrol, a natural polyphenolic compound, exhibits a broader anti-inflammatory mechanism. It is known to directly inhibit the activity of cyclooxygenase (COX) enzymes, similar

to NSAIDs. Furthermore, Resveratrol can suppress the activation of the NF- κ B pathway and down-regulate the expression of various inflammatory mediators.

Celecoxib is a selective COX-2 inhibitor. Its primary mechanism of action is the blockade of prostaglandin synthesis, which are key mediators of pain and inflammation. By selectively targeting COX-2, Celecoxib aims to reduce the gastrointestinal side effects associated with non-selective NSAIDs that also inhibit the protective COX-1 enzyme.

In Vivo Anti-Inflammatory Efficacy: Carrageenan-Induced Paw Edema

The carrageenan-induced paw edema model is a standard in vivo assay to evaluate the acute anti-inflammatory activity of compounds. The following table summarizes the dose-dependent effects of **FeTMPyP**, Resveratrol, and Celecoxib on the inhibition of paw edema in rats.

Compound	Dose	Route of Administration	Time Point	% Inhibition of Paw Edema	Reference
FeTMPyP	3 mg/kg	i.v.	3 hours	Approx. 20%	[3]
	10 mg/kg	i.v.	3 hours	Approx. 45%	[3]
	30 mg/kg	i.v.	3 hours	Approx. 60%	[3]
Resveratrol	20 mg/kg	i.p.	Not Specified	67%	
Celecoxib	3 mg/kg	i.p.	5 hours	Significant reduction	
	30 mg/kg	i.p.	5 hours	Significant reduction	

Note: The data for **FeTMPyP** is estimated from graphical representations in the cited literature and direct quantitative values were not available. The experimental conditions for each compound may vary across different studies, affecting direct comparability.

Modulation of Key Inflammatory Markers

The anti-inflammatory effects of these compounds are further substantiated by their ability to modulate the expression and activity of key inflammatory mediators.

Compound	Model System	Marker	Effect	Reference
FeTMPyP	Rat Neuropathic Pain Model	iNOS	Reduction	[2]
NF-κB	Reduction	[2]		
TNF-α	Reduction	[2]		
IL-6	Reduction	[2]		
Resveratrol	Various in vitro and in vivo models	COX-2	Inhibition	
NF-κB	Inhibition			
TNF-α	Reduction			
IL-6	Reduction			
Celecoxib	Rat Carrageenan-Induced Paw Edema	COX-2	Inhibition	
TNF-α	Reduction			
IL-6	Reduction			

Signaling Pathways

The following diagrams illustrate the key signaling pathways modulated by **FeTMPyP** and the comparative agents.

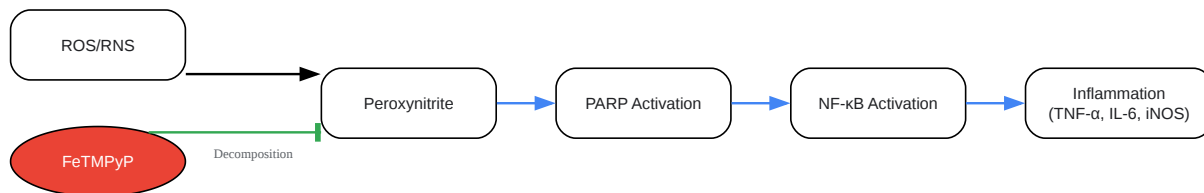

[Click to download full resolution via product page](#)

FeTMPyP's Mechanism of Action

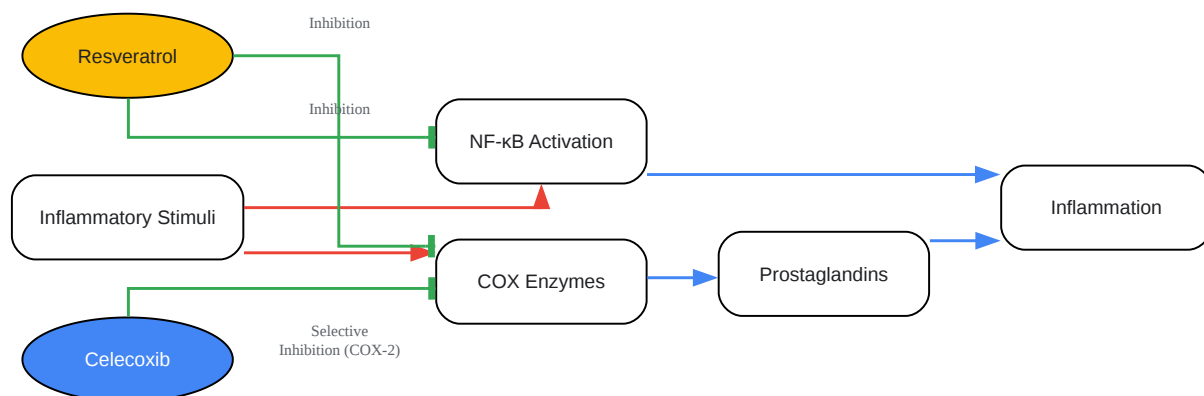

[Click to download full resolution via product page](#)

Mechanisms of Resveratrol and Celecoxib

Experimental Protocols

Carrageenan-Induced Paw Edema in Rats

This in vivo model is used to assess acute inflammation.

- Animals: Male Wistar rats (150-200 g) are typically used.
- Induction of Edema: A subplantar injection of 1% carrageenan solution (in saline) is administered into the right hind paw of the rats.

- **Drug Administration:** Test compounds (**FeTMPyP**, Resveratrol, Celecoxib) or vehicle are administered at various doses, typically intraperitoneally (i.p.) or intravenously (i.v.), at a specified time before or after carrageenan injection.
- **Measurement of Paw Volume:** The volume of the injected paw is measured at different time points (e.g., 1, 2, 3, 4, 5, and 6 hours) after carrageenan injection using a plethysmometer.
- **Calculation of Inhibition:** The percentage inhibition of edema is calculated for each group compared to the vehicle-treated control group.

Western Blot for iNOS Protein Expression

This in vitro technique is used to quantify the amount of a specific protein in a sample.

- **Sample Preparation:** Tissue or cell lysates are prepared from the area of inflammation (e.g., paw tissue) or from cell cultures treated with the test compounds.
- **Protein Quantification:** The total protein concentration in each lysate is determined using a standard assay (e.g., BCA assay).
- **SDS-PAGE:** Equal amounts of protein from each sample are separated by size using sodium dodecyl sulfate-polyacrylamide gel electrophoresis (SDS-PAGE).
- **Protein Transfer:** The separated proteins are transferred from the gel to a membrane (e.g., PVDF or nitrocellulose).
- **Immunoblotting:** The membrane is incubated with a primary antibody specific for iNOS, followed by a secondary antibody conjugated to an enzyme (e.g., HRP).
- **Detection:** The protein bands are visualized using a chemiluminescent substrate, and the band intensity is quantified using densitometry software.

Measurement of NF- κ B Activation

NF- κ B activation is often assessed by measuring its translocation from the cytoplasm to the nucleus.

- **Cell Culture and Treatment:** Macrophage cell lines (e.g., RAW 264.7) are cultured and treated with an inflammatory stimulus (e.g., LPS) in the presence or absence of the test compounds.
- **Nuclear and Cytoplasmic Fractionation:** The cells are lysed, and the nuclear and cytoplasmic fractions are separated by centrifugation.
- **Western Blot Analysis:** The levels of NF- κ B (typically the p65 subunit) in the nuclear and cytoplasmic fractions are determined by Western blotting as described above. An increase in the nuclear fraction and a corresponding decrease in the cytoplasmic fraction indicate NF- κ B activation.
- **Immunofluorescence Microscopy:** Alternatively, cells can be fixed, permeabilized, and stained with an anti-NF- κ B antibody. The subcellular localization of NF- κ B is then visualized using fluorescence microscopy.

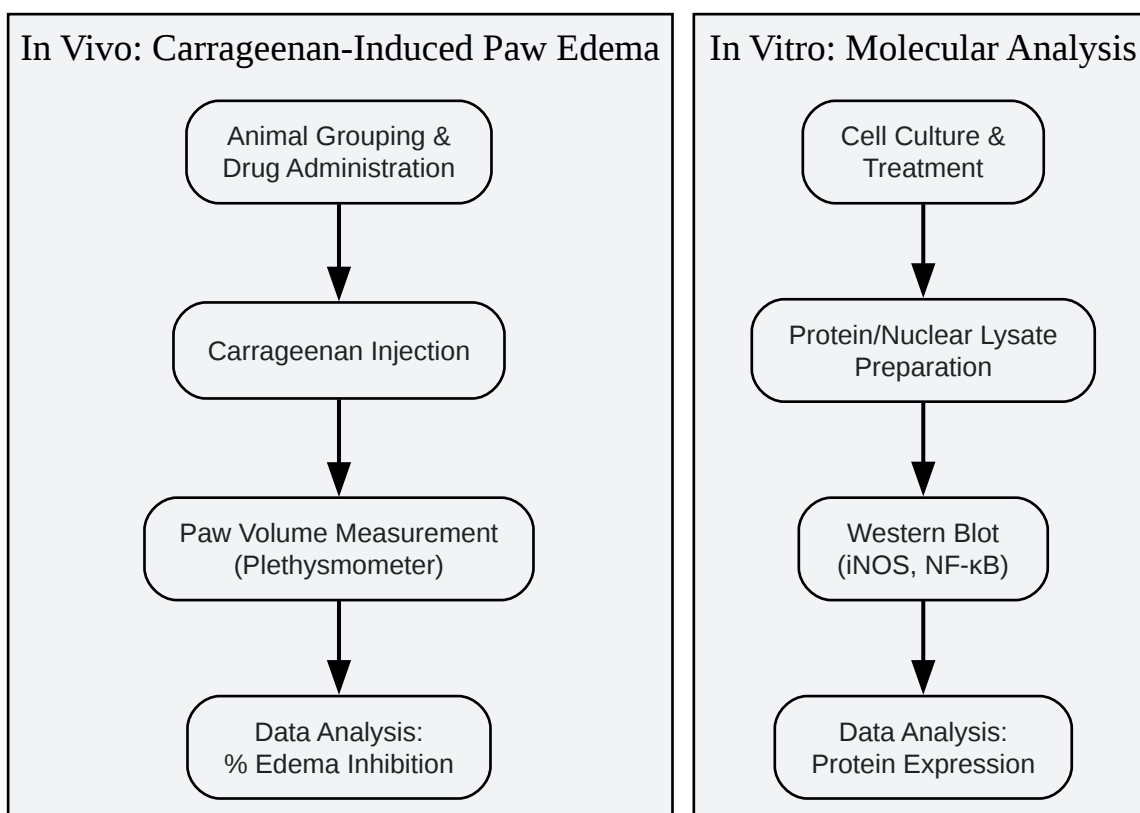

[Click to download full resolution via product page](#)

General Experimental Workflow

Conclusion

FeTMPyP demonstrates significant anti-inflammatory properties, primarily through its unique mechanism of peroxynitrite decomposition. This leads to a reduction in oxidative stress and the downstream inhibition of key inflammatory pathways. When compared to Resveratrol and Celecoxib, **FeTMPyP** offers a distinct mechanistic approach to inflammation control. While direct quantitative comparisons are challenging due to variations in experimental designs across studies, the available data suggests that **FeTMPyP** is a potent anti-inflammatory agent. Further head-to-head comparative studies under standardized conditions would be beneficial to fully elucidate its relative efficacy and potential therapeutic advantages.

Need Custom Synthesis?

BenchChem offers custom synthesis for rare earth carbides and specific isotopic labeling.

Email: info@benchchem.com or [Request Quote Online](#).

References

- 1. [pnas.org](https://www.pnas.org) [[pnas.org](https://www.pnas.org)]
- 2. FeTMPyP a peroxynitrite decomposition catalyst ameliorated functional and behavioral deficits in chronic constriction injury induced neuropathic pain in rats - PubMed [pubmed.ncbi.nlm.nih.gov]
- 3. Peroxynitrite decomposition catalysts: Therapeutics for peroxynitrite-mediated pathology - PMC [[pmc.ncbi.nlm.nih.gov](https://pubmed.ncbi.nlm.nih.gov)]
- To cite this document: BenchChem. [A Comparative Analysis of FeTMPyP's Anti-Inflammatory Properties]. BenchChem, [2026]. [Online PDF]. Available at: [<https://www.benchchem.com/product/b15583630/docs#a-comparative-analysis-of-fetmpyp-s-anti-inflammatory-properties>]

Disclaimer & Data Validity:

The information provided in this document is for Research Use Only (RUO) and is strictly not intended for diagnostic or therapeutic procedures. While BenchChem strives to provide

accurate protocols, we make no warranties, express or implied, regarding the fitness of this product for every specific experimental setup.

Technical Support: The protocols provided are for reference purposes. Unsure if this reagent suits your experiment?

Need Industrial/Bulk Grade? [Request Custom Synthesis Quote](#)

BenchChem

Our mission is to be the trusted global source of essential and advanced chemicals, empowering scientists and researchers to drive progress in science and industry.

Contact

Address: 3281 E Guasti Rd
Ontario, CA 91761, United States
Phone: (601) 213-4426
Email: info@benchchem.com

[Contact our Ph.D. Support Team for a compatibility check](#)