

Validating the Autophagy-Inducing Activity of QRPR Peptide: A Comparative Guide

Author: BenchChem Technical Support Team. **Date:** April 2026

Compound of Interest

Compound Name: Soybean peptide QRPR

Cat. No.: B15582308

[Get Quote](#)

This guide provides an objective comparison of the autophagy-inducing peptide QRPR with established methods of autophagy induction, namely rapamycin treatment and amino acid starvation. The performance of each method is evaluated based on key biochemical and morphological markers of autophagy, supported by experimental data. Detailed protocols for the cited experiments are also provided to enable researchers to reproduce and validate these findings.

Comparative Analysis of Autophagy Induction

The efficacy of QRPR peptide in inducing autophagy was compared to that of rapamycin, a well-known mTOR inhibitor, and nutrient starvation, a physiological inducer of autophagy. The comparison is based on the analysis of key autophagy markers in the murine macrophage cell line RAW264.7.

Inducer	Mechanism of Action	LC3-II/LC3-I Ratio	p62/SQSTM1 Protein Level	PI3K/AKT/mTOR Pathway Modulation	Autophagosome Formation
QRPR Peptide	Modulates the PI3K/AKT/mTOR signaling pathway.[1]	Increased	Decreased	Inhibition of PI3K, AKT, and mTOR phosphorylation.[1]	Observation of double-membrane autophagosomes via TEM. [1]
Rapamycin	Directly inhibits mTORC1, a key negative regulator of autophagy.	Increased[2]	Decreased	Potent inhibition of mTOR phosphorylation.	Increased formation of autophagosomes.[2]
Starvation	Inhibits mTORC1 signaling due to amino acid deprivation.	Increased	Decreased	Inhibition of mTOR signaling.	Robust induction of autophagosome formation.

Experimental Protocols

Cell Culture and Treatment

- Cell Line: Murine macrophage RAW264.7 cells.
- Culture Conditions: Cells are maintained in Dulbecco's Modified Eagle's Medium (DMEM) supplemented with 10% fetal bovine serum (FBS) and 1% penicillin-streptomycin at 37°C in a humidified atmosphere of 5% CO₂.
- QRPR Peptide Treatment: Cells are treated with QRPR peptide at various concentrations and for different time points as required by the specific experiment.

- **Rapamycin Treatment:** As a positive control for mTOR-dependent autophagy, cells are treated with rapamycin (e.g., 50 nM) for a specified duration (e.g., 24 hours).[2]
- **Starvation Protocol:** To induce autophagy through nutrient deprivation, cells are washed with phosphate-buffered saline (PBS) and incubated in Earle's Balanced Salt Solution (EBSS) or amino acid-free medium for a designated time (e.g., 2-4 hours).

Western Blot Analysis for Autophagy Markers

This protocol is used to quantify the protein levels of key autophagy markers.

- **Cell Lysis:** After treatment, cells are washed with ice-cold PBS and lysed in RIPA buffer containing protease and phosphatase inhibitors.
- **Protein Quantification:** The total protein concentration of the lysates is determined using a BCA protein assay.
- **SDS-PAGE and Protein Transfer:** Equal amounts of protein (e.g., 20-30 µg) are separated by SDS-polyacrylamide gel electrophoresis and transferred to a polyvinylidene difluoride (PVDF) membrane.
- **Immunoblotting:**
 - The membrane is blocked with 5% non-fat milk or bovine serum albumin (BSA) in Tris-buffered saline with 0.1% Tween 20 (TBST) for 1 hour at room temperature.
 - The membrane is then incubated overnight at 4°C with primary antibodies specific for:
 - LC3B (to detect both LC3-I and LC3-II)
 - p62/SQSTM1
 - Phospho-PI3K, PI3K
 - Phospho-AKT, AKT
 - Phospho-mTOR, mTOR

- β -actin (as a loading control)
 - After washing with TBST, the membrane is incubated with the appropriate horseradish peroxidase (HRP)-conjugated secondary antibody for 1 hour at room temperature.
- Detection: The protein bands are visualized using an enhanced chemiluminescence (ECL) detection system. The band intensities are quantified using densitometry software, and the LC3-II/LC3-I ratio and the relative expression of other proteins are calculated after normalization to the loading control.

Transmission Electron Microscopy (TEM) for Autophagosome Visualization

TEM is the gold standard for morphological confirmation of autophagosome formation.

- Cell Fixation: Cells are fixed with a solution containing 2.5% glutaraldehyde and 2% paraformaldehyde in 0.1 M phosphate buffer (pH 7.4) for 1 hour at 4°C.
- Post-fixation and Dehydration: Cells are post-fixed in 1% osmium tetroxide, followed by dehydration through a graded series of ethanol concentrations.
- Embedding and Sectioning: The dehydrated cell pellets are embedded in resin. Ultrathin sections (70-90 nm) are cut using an ultramicrotome.
- Staining and Imaging: The sections are stained with uranyl acetate and lead citrate and then examined under a transmission electron microscope to identify the characteristic double-membrane structure of autophagosomes.

Visualizations

Signaling Pathway

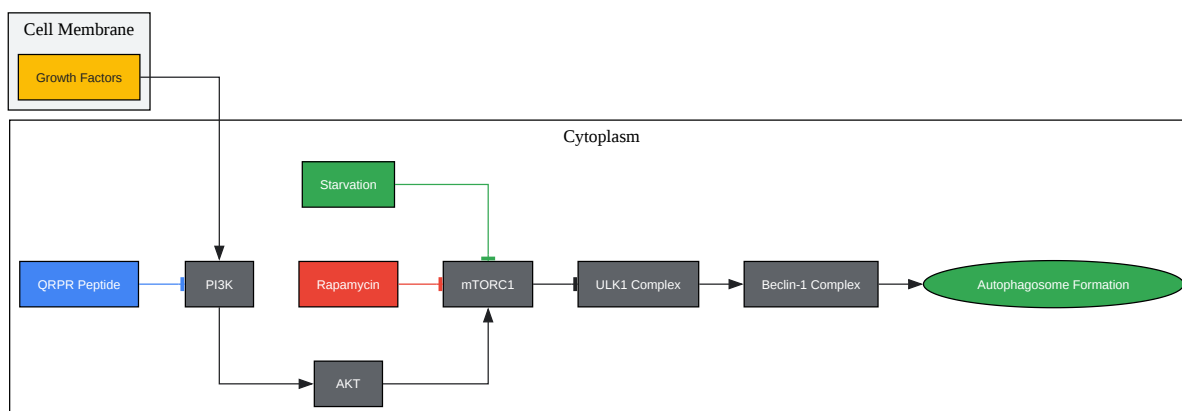

[Click to download full resolution via product page](#)

Caption: QRPR peptide, rapamycin, and starvation induce autophagy by inhibiting the mTORC1 signaling pathway.

Experimental Workflow

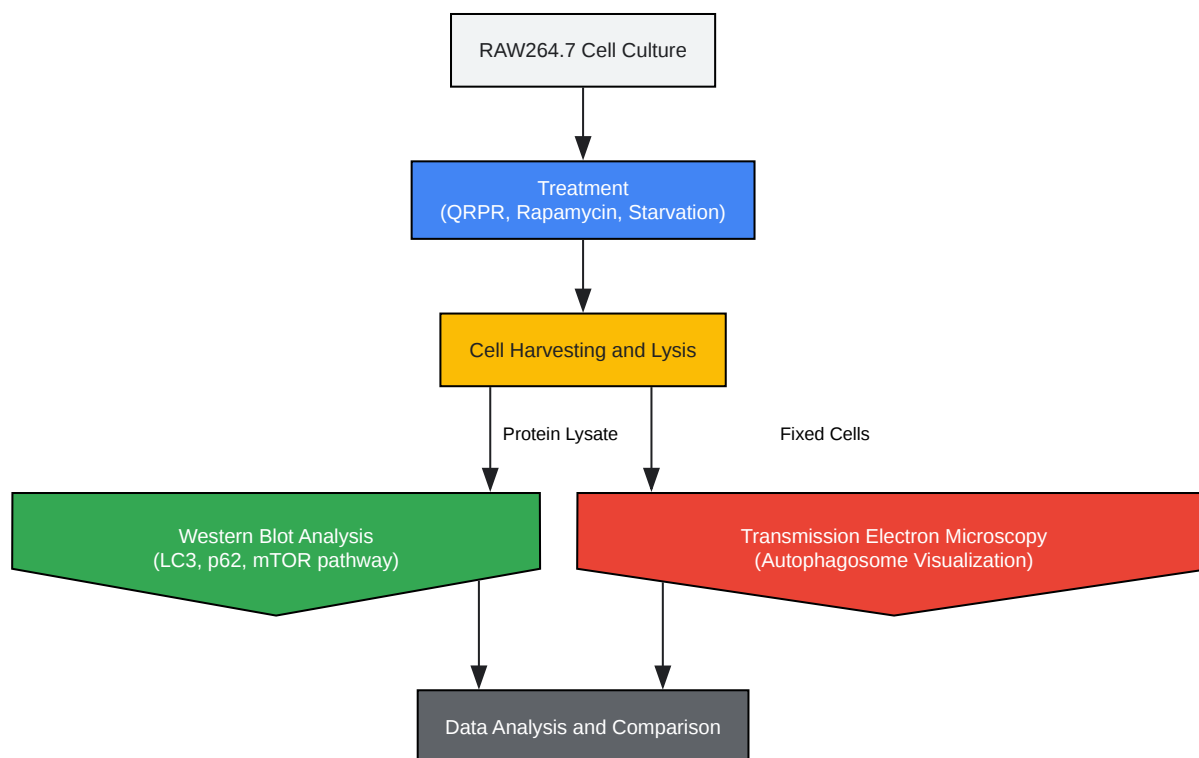

[Click to download full resolution via product page](#)

Caption: Workflow for validating the autophagy-inducing activity of QRPR peptide.

Need Custom Synthesis?

BenchChem offers custom synthesis for rare earth carbides and specific isotopic labeling.

Email: info@benchchem.com or [Request Quote Online](#).

References

- 1. [researchgate.net](https://www.researchgate.net) [researchgate.net]
- 2. resources.novusbio.com [resources.novusbio.com]

- To cite this document: BenchChem. [Validating the Autophagy-Inducing Activity of QRPR Peptide: A Comparative Guide]. BenchChem, [2026]. [Online PDF]. Available at: [<https://www.benchchem.com/product/b15582308/docs#validating-the-autophagy-inducing-activity-of-qrpr-peptide-a-comparative-guide>]

Disclaimer & Data Validity:

The information provided in this document is for Research Use Only (RUO) and is strictly not intended for diagnostic or therapeutic procedures. While BenchChem strives to provide accurate protocols, we make no warranties, express or implied, regarding the fitness of this product for every specific experimental setup.

Technical Support: The protocols provided are for reference purposes. Unsure if this reagent suits your experiment?

Need Industrial/Bulk Grade? [Request Custom Synthesis Quote](#)

BenchChem

Our mission is to be the trusted global source of essential and advanced chemicals, empowering scientists and researchers to drive progress in science and industry.

Contact

Address: 3281 E Guasti Rd
Ontario, CA 91761, United States
Phone: (601) 213-4426
Email: info@benchchem.com

[Contact our Ph.D. Support Team for a compatibility check](#)