

# An In-depth Technical Guide to EGFRvIII Peptide Signaling Pathways

**Author:** BenchChem Technical Support Team. **Date:** April 2026

## Compound of Interest

Compound Name: EGFRvIII peptide

Cat. No.: B15582649

[Get Quote](#)

For Researchers, Scientists, and Drug Development Professionals

## Abstract

The epidermal growth factor receptor variant III (EGFRvIII) is a constitutively active mutant of the EGFR that is frequently expressed in glioblastoma and other cancers.<sup>[1][2][3]</sup> Its ligand-independent signaling activity drives tumor progression, making it a critical target for therapeutic development.<sup>[2][3]</sup> This technical guide provides a comprehensive overview of the core signaling pathways activated by EGFRvIII, detailed experimental protocols for their investigation, and a summary of quantitative data to facilitate comparative analysis.

## Core EGFRvIII Signaling Pathways

EGFRvIII orchestrates a complex network of intracellular signaling cascades that promote cell proliferation, survival, invasion, and angiogenesis.<sup>[2][4][5]</sup> The primary pathways activated by the constitutive kinase activity of EGFRvIII include the PI3K/AKT/mTOR, RAS/MEK/ERK, JAK/STAT, and PLC $\gamma$  pathways.<sup>[2][4][6]</sup>

## PI3K/AKT/mTOR Pathway

The phosphatidylinositol 3-kinase (PI3K)/AKT pathway is a central signaling axis downstream of EGFRvIII, playing a crucial role in cell survival and proliferation.[6][7] Upon activation, EGFRvIII recruits and phosphorylates the p85 regulatory subunit of PI3K, leading to the activation of the p110 catalytic subunit. Activated PI3K phosphorylates phosphatidylinositol (4,5)-bisphosphate (PIP2) to generate phosphatidylinositol (3,4,5)-trisphosphate (PIP3). PIP3 acts as a second messenger, recruiting proteins with pleckstrin homology (PH) domains, such as AKT and PDK1, to the plasma membrane. This co-localization facilitates the phosphorylation and activation of AKT by PDK1 and mTORC2. Activated AKT then phosphorylates a multitude of downstream substrates, including mTOR, to promote cell growth, proliferation, and survival, while inhibiting apoptosis.[2] Studies have shown that the PI3K pathway is often the dominant signaling cascade activated by high levels of EGFRvIII expression.[8][9][10]

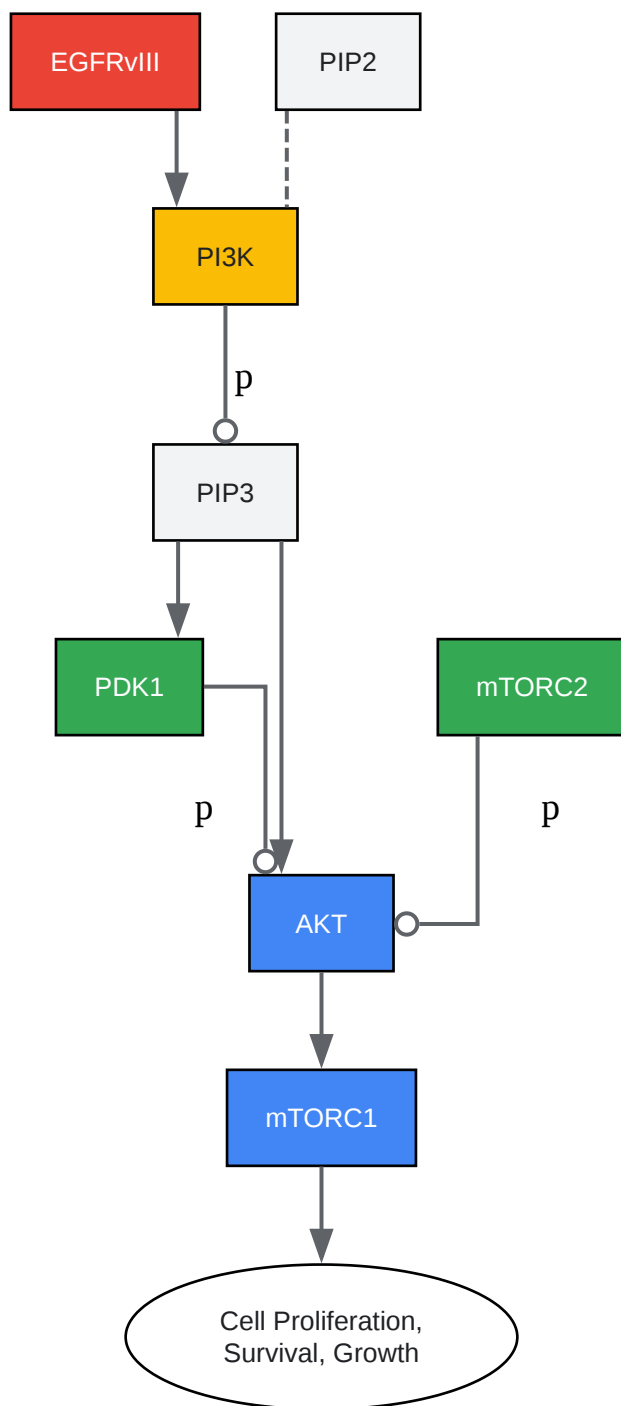

[Click to download full resolution via product page](#)

Caption: The PI3K/AKT/mTOR signaling pathway activated by EGFRvIII.

## RAS/MEK/ERK Pathway

The RAS/MEK/ERK pathway, also known as the MAPK pathway, is another critical downstream effector of EGFRvIII, primarily regulating cell proliferation and differentiation.[2][4] Activated EGFRvIII recruits the adaptor protein Grb2, which in turn binds to the Son of Sevenless (SOS) guanine nucleotide exchange factor.[4][11] SOS then activates RAS by promoting the exchange of GDP for GTP.[12] GTP-bound RAS activates the serine/threonine kinase RAF, initiating a phosphorylation cascade that sequentially activates MEK1/2 and then ERK1/2.[4][11] Activated ERK translocates to the nucleus to phosphorylate and activate various transcription factors, leading to the expression of genes involved in cell cycle progression and proliferation.[4]

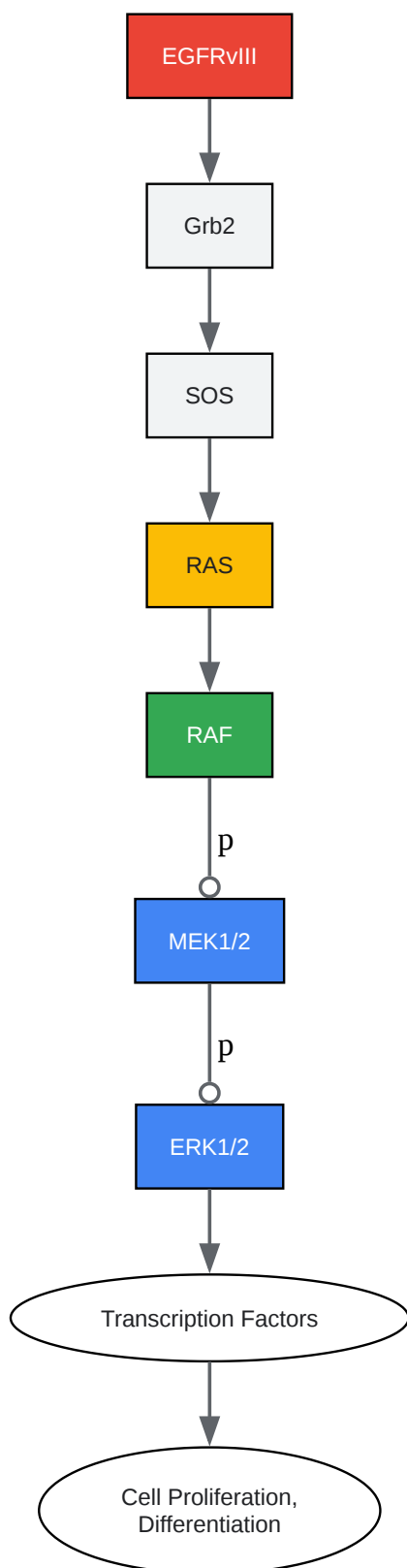

[Click to download full resolution via product page](#)

Caption: The RAS/MEK/ERK (MAPK) signaling pathway initiated by EGFRvIII.

## JAK/STAT Pathway

The Janus kinase (JAK)/signal transducer and activator of transcription (STAT) pathway is also activated by EGFRvIII and is implicated in promoting tumor cell invasion and survival.[2][13] EGFRvIII can directly phosphorylate STAT3 and STAT5. Additionally, EGFRvIII can associate with and activate JAK2, which in turn phosphorylates STAT proteins.[13] Upon phosphorylation, STAT proteins dimerize and translocate to the nucleus, where they act as transcription factors to regulate the expression of genes involved in cell motility, survival, and immune suppression. [2] There is evidence of a complex interplay where STAT3 can form a complex with EGFRvIII, driving malignant transformation.[2]

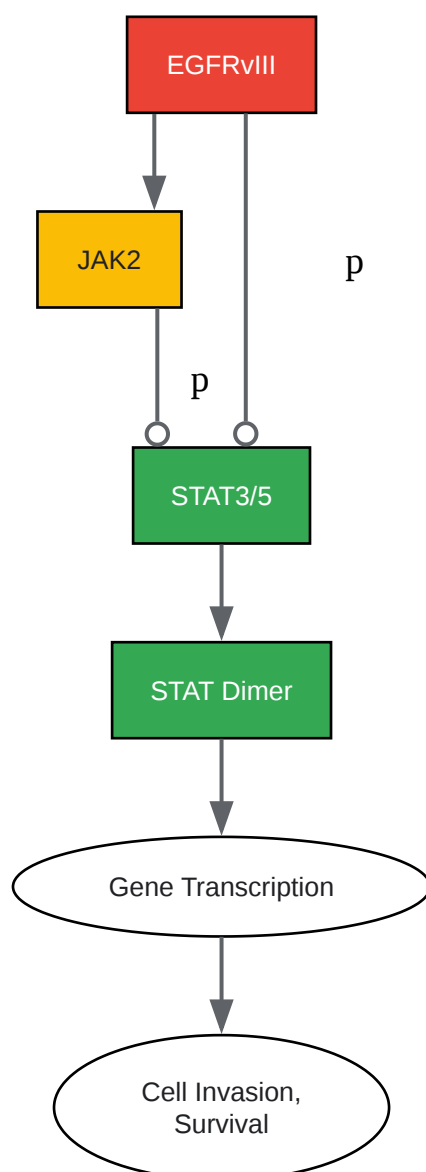

[Click to download full resolution via product page](#)

Caption: The JAK/STAT signaling pathway activated downstream of EGFRvIII.

## PLC $\gamma$ Pathway

The Phospholipase C gamma (PLC $\gamma$ ) pathway is another important signaling route activated by EGFRvIII.[2][4] Activated EGFRvIII recruits and phosphorylates PLC $\gamma$  at tyrosine residue Y783, leading to its activation. Activated PLC $\gamma$  then catalyzes the hydrolysis of PIP2 into two second messengers: inositol 1,4,5-trisphosphate (IP3) and diacylglycerol (DAG).[4] IP3 binds to receptors on the endoplasmic reticulum, causing the release of intracellular calcium stores. DAG, along with calcium, activates protein kinase C (PKC). The activation of the PLC $\gamma$ /PKC axis contributes to various cellular processes, including proliferation, migration, and angiogenesis.[2]

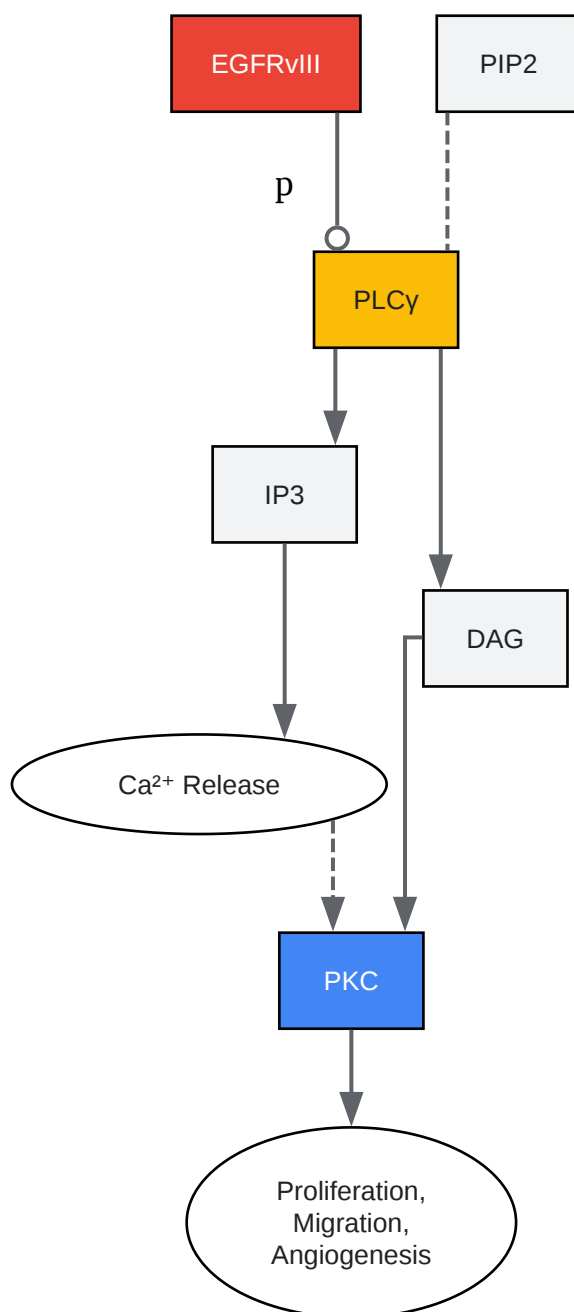

[Click to download full resolution via product page](#)

Caption: The PLC $\gamma$  signaling pathway downstream of EGFRvIII activation.

## Quantitative Data on EGFRvIII Signaling

Mass spectrometry-based phosphoproteomics has been instrumental in quantifying the signaling events downstream of EGFRvIII.[1][8] These studies have provided valuable insights into the differential activation of pathways and the identification of potential therapeutic targets.

Table 1: Quantified Phosphorylation Sites on EGFRvIII and Key Downstream Effectors. This table summarizes the fold change in phosphorylation of key signaling proteins in EGFRvIII-expressing cells compared to control cells, as determined by mass spectrometry.

Protein	Phosphorylation Site	Fold Change (EGFRvIII vs. Control)	Key Function	Reference
EGFRvIII	Multiple Tyrosine Sites	Constitutively Phosphorylated	Kinase Activity	[8]
GAB1	Y627	> 3-fold increase	PI3K Pathway Adaptor	[8]
PIK3R1 (p85)	Y467	> 3-fold increase	PI3K Activation	[8]
c-Met	Y1234/Y1235	Highly responsive to EGFRvIII levels	Receptor Tyrosine Kinase	[8][9]
PLCy1	Y783	~2-fold increase	PLCy Activation	
STAT3	Y705	Increased Phosphorylation	Transcription Factor	[2]
ERK1/2	T202/Y204	Modest Increase	MAPK Pathway	[8]

Data is compiled from multiple studies and represents a generalized summary. Actual values may vary based on the specific experimental system.

## Experimental Protocols

This section provides detailed methodologies for key experiments used to investigate EGFRvIII signaling pathways.

### Immunoprecipitation of EGFRvIII

This protocol is for the isolation of EGFRvIII from cell lysates to study its interaction with other proteins.

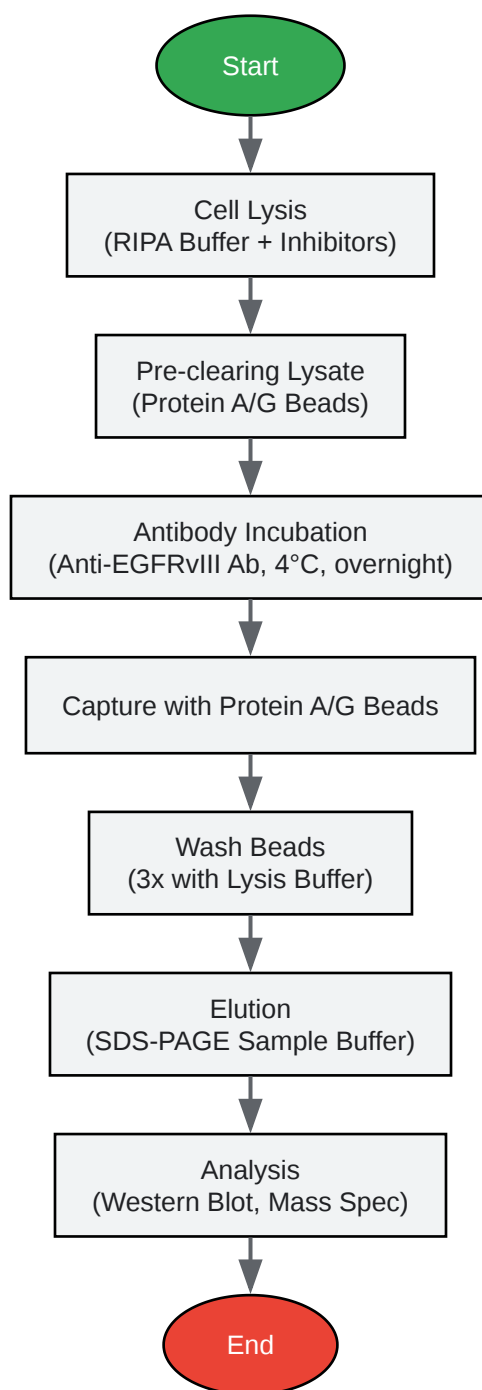

[Click to download full resolution via product page](#)

Caption: Workflow for the immunoprecipitation of EGFRvIII.

Materials:

- Cells expressing EGFRvIII

- Ice-cold Phosphate-Buffered Saline (PBS)
- RIPA Lysis Buffer (50 mM Tris-HCl pH 7.4, 150 mM NaCl, 1% NP-40, 0.5% sodium deoxycholate, 0.1% SDS) supplemented with protease and phosphatase inhibitors
- Anti-EGFRvIII antibody
- Protein A/G agarose or magnetic beads
- 2x Laemmli sample buffer

Procedure:

- Culture cells to 80-90% confluency.
- Wash cells twice with ice-cold PBS.
- Lyse cells by adding ice-cold RIPA buffer and scraping.
- Incubate the lysate on ice for 30 minutes with occasional vortexing.
- Clarify the lysate by centrifugation at 14,000 x g for 15 minutes at 4°C.
- Transfer the supernatant to a new tube and determine the protein concentration.
- Pre-clear the lysate by incubating with protein A/G beads for 1 hour at 4°C.
- Centrifuge and transfer the supernatant to a new tube.
- Add the anti-EGFRvIII antibody to the pre-cleared lysate and incubate overnight at 4°C with gentle rotation.
- Add protein A/G beads and incubate for 2-4 hours at 4°C.
- Pellet the beads by centrifugation and wash three times with ice-cold lysis buffer.
- After the final wash, aspirate the supernatant and resuspend the beads in 2x Laemmli sample buffer.

- Boil the samples for 5-10 minutes to elute the proteins.
- Centrifuge to pellet the beads and collect the supernatant for analysis by Western blot or mass spectrometry.

## Western Blot Analysis of Phosphorylated EGFRvIII and Downstream Effectors

This protocol details the detection of phosphorylated proteins in EGFRvIII signaling pathways.

Materials:

- Cell lysates prepared as in the immunoprecipitation protocol
- SDS-PAGE gels
- PVDF or nitrocellulose membranes
- Transfer buffer
- Blocking buffer (5% BSA in TBST)
- Primary antibodies (e.g., anti-phospho-EGFRvIII, anti-phospho-AKT, anti-phospho-ERK)
- HRP-conjugated secondary antibodies
- Chemiluminescent substrate

Procedure:

- Separate proteins from cell lysates by SDS-PAGE.
- Transfer the separated proteins to a PVDF or nitrocellulose membrane.
- Block the membrane with 5% BSA in TBST for 1 hour at room temperature.
- Incubate the membrane with the primary antibody (diluted in 5% BSA/TBST) overnight at 4°C with gentle agitation.

- Wash the membrane three times for 10 minutes each with TBST.
- Incubate the membrane with the HRP-conjugated secondary antibody (diluted in 5% milk/TBST) for 1 hour at room temperature.
- Wash the membrane three times for 10 minutes each with TBST.
- Incubate the membrane with a chemiluminescent substrate and visualize the signal using an imaging system.
- To analyze total protein levels, the membrane can be stripped and re-probed with an antibody against the non-phosphorylated form of the protein.

## In Vitro Kinase Assay for EGFRvIII Activity

This protocol is for measuring the kinase activity of EGFRvIII, often used to screen for inhibitors.

### Materials:

- Recombinant EGFRvIII enzyme
- Kinase assay buffer (e.g., 40mM Tris-HCl, pH 7.5, 20mM MgCl<sub>2</sub>, 0.1mg/ml BSA)
- Peptide substrate (e.g., Poly(Glu, Tyr) 4:1)
- ATP
- ADP-Glo™ Kinase Assay Kit (Promega) or similar luminescence-based assay

### Procedure:

- Prepare serial dilutions of the test compound (potential inhibitor) in kinase assay buffer.
- In a 96-well plate, add the test compound or vehicle control.
- Add the recombinant EGFRvIII enzyme to each well.
- Add the peptide substrate and ATP to initiate the kinase reaction.

- Incubate the plate at 30°C for a specified time (e.g., 60 minutes).
- Stop the reaction and deplete the remaining ATP by adding the ADP-Glo™ Reagent.
- Incubate at room temperature for 40 minutes.
- Add the Kinase Detection Reagent to convert ADP to ATP and generate a luminescent signal.
- Incubate at room temperature for 30 minutes.
- Measure the luminescence using a plate reader. The signal is proportional to the amount of ADP produced and thus the kinase activity.

## Conclusion

This technical guide provides a foundational understanding of the core signaling pathways driven by EGFRvIII, methods for their investigation, and a summary of quantitative data. The constitutive activation of multiple oncogenic pathways by EGFRvIII underscores its importance as a therapeutic target. The provided experimental protocols offer a starting point for researchers to further dissect the complexities of EGFRvIII signaling and to evaluate the efficacy of novel therapeutic strategies. A thorough understanding of these pathways and the tools to study them is essential for the development of effective treatments for EGFRvIII-positive cancers.

### *Need Custom Synthesis?*

*BenchChem offers custom synthesis for rare earth carbides and specific isotopic labeling.*

*Email: [info@benchchem.com](mailto:info@benchchem.com) or [Request Quote Online](#).*

## References

- [1. Quantitative phosphoproteomics by mass spectrometry: Past, present, and future - PMC \[pmc.ncbi.nlm.nih.gov\]](#)
- [2. academic.oup.com \[academic.oup.com\]](#)

- 3. Epidermal growth factor receptor (EGFR) and EGFRvIII in glioblastoma (GBM): signaling pathways and targeted therapies - PMC [[pmc.ncbi.nlm.nih.gov](https://pubmed.ncbi.nlm.nih.gov/)]
- 4. [antibody-creativebiolabs.com](https://antibody-creativebiolabs.com) [[antibody-creativebiolabs.com](https://antibody-creativebiolabs.com)]
- 5. Immunoprecipitation Protocol: Novus Biologicals [[novusbio.com](https://novusbio.com)]
- 6. Phosphoproteomic investigation of targets of protein phosphatases in EGFR signaling - PMC [[pmc.ncbi.nlm.nih.gov](https://pubmed.ncbi.nlm.nih.gov/)]
- 7. JAK2/STAT3 targeted therapy suppresses tumor invasion via disruption of the EGFRvIII/JAK2/STAT3 axis and associated focal adhesion in EGFRvIII-expressing glioblastoma - PubMed [[pubmed.ncbi.nlm.nih.gov](https://pubmed.ncbi.nlm.nih.gov/)]
- 8. [researchgate.net](https://researchgate.net) [[researchgate.net](https://researchgate.net)]
- 9. Development of an EGFRvIII specific recombinant antibody - PMC [[pmc.ncbi.nlm.nih.gov](https://pubmed.ncbi.nlm.nih.gov/)]
- 10. [promega.com](https://promega.com) [[promega.com](https://promega.com)]
- 11. [documents.thermofisher.com](https://documents.thermofisher.com) [[documents.thermofisher.com](https://documents.thermofisher.com)]
- 12. Molecular Characterization of EGFR and EGFRvIII Signaling Networks in Human Glioblastoma Tumor Xenografts - PMC [[pmc.ncbi.nlm.nih.gov](https://pubmed.ncbi.nlm.nih.gov/)]
- 13. [benchchem.com](https://benchchem.com) [[benchchem.com](https://benchchem.com)]
- To cite this document: BenchChem. [An In-depth Technical Guide to EGFRvIII Peptide Signaling Pathways]. BenchChem, [2026]. [Online PDF]. Available at: [<https://www.benchchem.com/product/b15582649/docs#an-in-depth-technical-guide-to-egfrviii-peptide-signaling-pathways>]

---

### Disclaimer & Data Validity:

The information provided in this document is for Research Use Only (RUO) and is strictly not intended for diagnostic or therapeutic procedures. While BenchChem strives to provide accurate protocols, we make no warranties, express or implied, regarding the fitness of this product for every specific experimental setup.

**Technical Support:** The protocols provided are for reference purposes. Unsure if this reagent suits your experiment?

**Need Industrial/Bulk Grade?** [Request Custom Synthesis Quote](#)

# BenchChem

Our mission is to be the trusted global source of essential and advanced chemicals, empowering scientists and researchers to drive progress in science and industry.

## Contact

Address: 3281 E Guasti Rd

Ontario, CA 91761, United States

Phone: (601) 213-4426

Email: [info@benchchem.com](mailto:info@benchchem.com)

[Contact our Ph.D. Support Team for a compatibility check](#)