

# comparative analysis of bioorthogonal labeling techniques

**Author:** BenchChem Technical Support Team. **Date:** April 2026

## Compound of Interest

Compound Name: *Biotin-PEG4-methyltetrazine*

Cat. No.: *B15580222*

[Get Quote](#)

## A Comparative Guide to Bioorthogonal Labeling Techniques

For Researchers, Scientists, and Drug Development Professionals

Bioorthogonal chemistry refers to chemical reactions that can occur inside living systems without interfering with native biochemical processes.<sup>[1][2]</sup> This powerful toolkit enables the precise labeling, visualization, and manipulation of biomolecules—such as proteins, glycans, and lipids—in their natural environment.<sup>[1][3]</sup> The selection of an appropriate bioorthogonal reaction is critical and depends on factors like reaction speed, biocompatibility, and the specific biological question being addressed.<sup>[4][5]</sup>

This guide provides a comparative analysis of the most prominent bioorthogonal labeling techniques, supported by quantitative data and detailed experimental protocols to aid researchers in making informed decisions for their experimental designs.

### Quantitative Performance Comparison

The efficacy of a bioorthogonal reaction is often quantified by its second-order rate constant ( $k_2$ ), which reflects how quickly the reaction proceeds at given reactant concentrations. A higher

rate constant is crucial for labeling low-abundance biomolecules or tracking rapid dynamic processes in vivo.[4] The table below summarizes the key performance metrics for several leading bioorthogonal labeling reactions.

Reaction Technique	Reactant 1	Reactant 2	Second-Order Rate Constant ( $k_2$ ) ( $M^{-1}s^{-1}$ )	Key Features & Advantages
Tetrazine Ligation (IEDDA)	Tetrazine (Tz)	trans-Cyclooctene (TCO)	$1 - 1 \times 10^6$ [6][7]	Exceptionally fast kinetics, highly specific, no catalyst required, ideal for in vivo applications and low concentration labeling.[8][9][10]
Strain-Promoted Alkyne-Azide Cycloaddition (SPAAC)	Strained Cyclooctyne	Azide	$10^{-3} - 1$	Metal-free "click chemistry", good biocompatibility, widely used for live-cell imaging. [1][11][12] Reaction rate is highly dependent on the specific cyclooctyne structure.[13]
Staudinger Ligation	Triarylphosphine	Azide	$\sim 7.7 \times 10^{-3}$ [14][15]	The first bioorthogonal reaction developed; foundational but has slower kinetics compared to newer methods. [1][16]

---

Nitron-  
Cyclooctyne  
Cycloaddition

Nitron

Cyclooctyne

12 - 32<sup>[1]</sup>

Fast, metal-free reaction, but incorporating the nitron handle into biomolecules can be challenging.<sup>[1]</sup>

---

## Reaction Mechanisms and Workflows

Understanding the underlying chemical transformations and general experimental procedures is key to successfully applying these techniques.

### Mechanism of Staudinger Ligation

The Staudinger ligation is a modification of the classic Staudinger reduction. It involves the reaction of an azide with a triarylphosphine, which is engineered with an electrophilic trap (e.g., a methyl ester). The initial reaction forms an aza-ylide intermediate, which is then trapped in an intramolecular reaction to form a stable amide bond, covalently linking the two molecules.<sup>[17]</sup>  
<sup>[18]</sup>

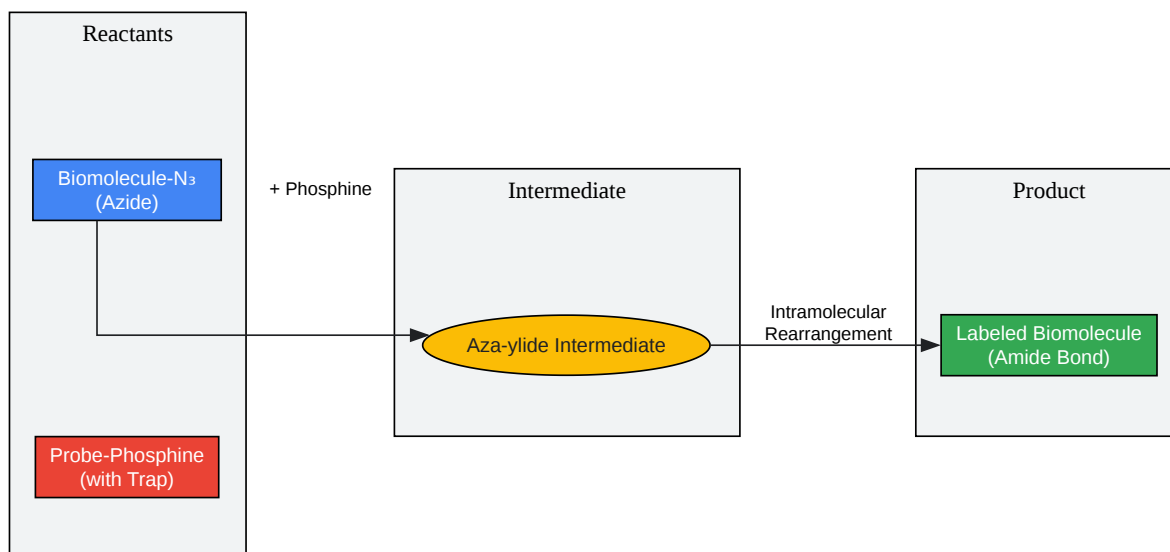

[Click to download full resolution via product page](#)

**Caption:** Mechanism of the Staudinger Ligation reaction.

## Mechanism of Strain-Promoted Alkyne-Azide Cycloaddition (SPAAC)

SPAAC is a metal-free variant of click chemistry that utilizes a strained cyclooctyne.<sup>[11]</sup> The ring strain of the cyclooctyne provides the energy to drive the [3+2] cycloaddition reaction with an azide, forming a stable triazole linkage without the need for a cytotoxic copper catalyst.<sup>[1]</sup><sup>[19]</sup> This makes it highly suitable for applications in living systems.

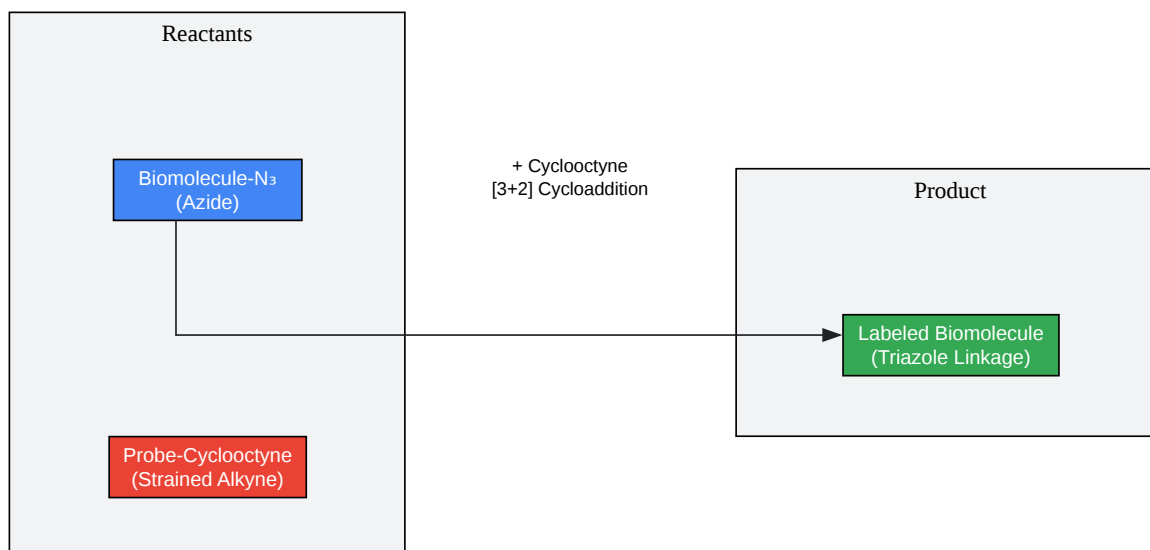

[Click to download full resolution via product page](#)

**Caption:** Mechanism of the Strain-Promoted Alkyne-Azide Cycloaddition (SPAAC).

## Mechanism of Inverse-Electron-Demand Diels-Alder (IEDDA) Ligation

The IEDDA reaction, often called the tetrazine ligation, is the fastest known bioorthogonal reaction.[2] It occurs between an electron-deficient diene (a tetrazine) and a strained, electron-rich dienophile (like trans-cyclooctene, TCO).[20] The reaction proceeds via a [4+2] cycloaddition, followed by a retro-Diels-Alder reaction that irreversibly releases nitrogen gas (N<sub>2</sub>), driving the reaction to completion.[8][9]

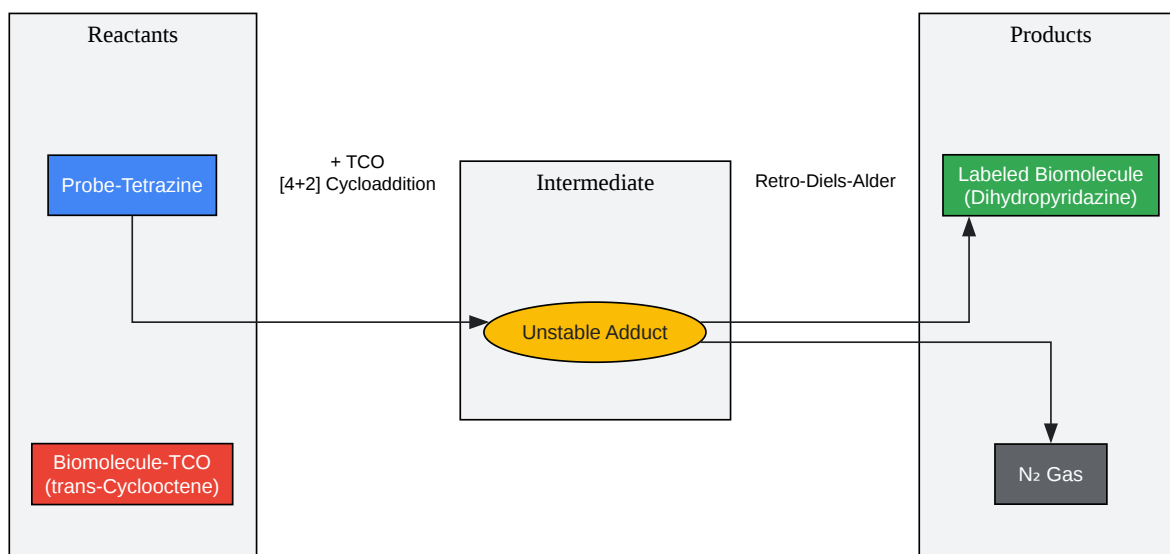

[Click to download full resolution via product page](#)

**Caption:** Mechanism of the Inverse-Electron-Demand Diels-Alder (IEDDA) reaction.

## General Experimental Workflow

Most bioorthogonal labeling experiments follow a two-step process. First, a biomolecule of interest is tagged with a chemical reporter group (e.g., an azide or TCO). This is often achieved metabolically, for instance, by feeding cells an unnatural sugar derivative.<sup>[18]</sup> Second, a probe molecule containing the complementary reactive group and a functional tag (e.g., a fluorophore or biotin) is introduced. The bioorthogonal reaction then selectively links the probe to the target biomolecule for subsequent detection or isolation.<sup>[1]</sup>

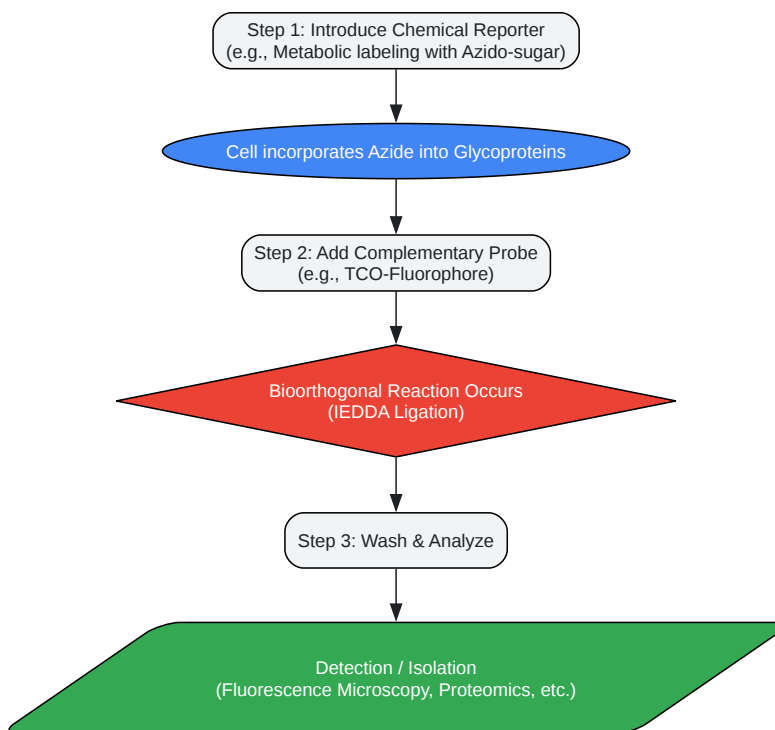

[Click to download full resolution via product page](#)

**Caption:** A general workflow for a two-step bioorthogonal labeling experiment.

## Experimental Protocols

The following protocols provide standardized methodologies for common bioorthogonal labeling applications.

### Protocol 1: SPAAC for Cell Surface Glycan Labeling

This protocol describes the labeling of cell surface glycans that have been metabolically tagged with an azido sugar, followed by reaction with a strained alkyne probe.

**Materials:**

- Cells cultured with an appropriate azido sugar (e.g., Ac<sub>4</sub>ManNAz) for 48-72 hours.
- Strained alkyne probe (e.g., DBCO-Fluorophore), 10 mM stock in DMSO.
- Phosphate-buffered saline (PBS), pH 7.4.
- Cell culture medium.

**Procedure:**

- After metabolic labeling, gently wash the cells three times with ice-cold PBS to remove unincorporated azido sugars.
- Prepare the labeling solution by diluting the strained alkyne probe stock solution in cell culture medium or PBS to a final concentration of 10-50 μM.
- Add the labeling solution to the cells and incubate for 30-60 minutes at 37°C or room temperature.
- Remove the labeling solution and wash the cells three times with PBS to remove the unreacted probe.
- The cells are now ready for analysis (e.g., fluorescence microscopy or flow cytometry).

## Protocol 2: Tetrazine Ligation for Protein-Protein Conjugation

This protocol outlines the rapid and efficient conjugation of two proteins, one modified with a trans-cyclooctene (TCO) group and the other with a tetrazine (Tz) group.<sup>[6][7]</sup>

**Materials:**

- TCO-modified Protein 1 in PBS, pH 7.4.
- Tetrazine-modified Protein 2 in PBS, pH 7.4.

- PBS, pH 7.4.

#### Procedure:

- Prepare solutions of TCO-Protein 1 and Tz-Protein 2 in PBS at the desired concentrations (typically in the low micromolar range).
- Mix the two protein solutions in a 1:1 molar ratio in a microcentrifuge tube.
- Incubate the reaction mixture at room temperature. Due to the extremely fast kinetics, the reaction is often complete within 5-30 minutes.[\[21\]](#)
- The resulting protein-protein conjugate can be used directly or purified from any unreacted starting material by size-exclusion chromatography if necessary.

## Protocol 3: Staudinger Ligation for Labeling Proteins in a Cell Lysate

This protocol details the labeling of an azide-modified protein in a complex cell lysate with a phosphine-biotin probe for subsequent enrichment.[\[7\]](#)

#### Materials:

- Cell lysate containing azide-modified target protein.
- Phosphine-probe conjugate (e.g., Phosphine-Biotin), 10 mM stock in DMSO.
- Lysis buffer (e.g., RIPA buffer).
- PBS, pH 7.4.

#### Procedure:

- Quantify the total protein concentration of the cell lysate using a standard protein assay (e.g., BCA).
- To 1 mg of total protein in lysate, add the phosphine-biotin probe to a final concentration of 100-250  $\mu$ M.

- Incubate the reaction at room temperature for 2-4 hours with gentle rotation.
- The biotin-labeled protein is now ready for enrichment using streptavidin-coated beads, followed by analysis via Western blot or mass spectrometry.

### Need Custom Synthesis?

BenchChem offers custom synthesis for rare earth carbides and specific isotopic labeling.

Email: [info@benchchem.com](mailto:info@benchchem.com) or [Request Quote Online](#).

## References

1. Bioorthogonal chemistry - Wikipedia [[en.wikipedia.org](https://en.wikipedia.org)]
2. Designing Bioorthogonal Reactions for Biomedical Applications - PMC [[pmc.ncbi.nlm.nih.gov](https://pubmed.ncbi.nlm.nih.gov)]
3. Making Connections: Click Chemistry and Bioorthogonal Chemistry | The Scientist [[the-scientist.com](https://www.the-scientist.com)]
4. Click Chemistry in Complex Mixtures: Bioorthogonal Bioconjugation - PMC [[pmc.ncbi.nlm.nih.gov](https://pubmed.ncbi.nlm.nih.gov)]
5. Developing bioorthogonal probes to span a spectrum of reactivities - PMC [[pmc.ncbi.nlm.nih.gov](https://pubmed.ncbi.nlm.nih.gov)]
6. [broadpharm.com](https://www.broadpharm.com) [[broadpharm.com](https://www.broadpharm.com)]
7. [benchchem.com](https://www.benchchem.com) [[benchchem.com](https://www.benchchem.com)]
8. [pubs.acs.org](https://pubs.acs.org) [[pubs.acs.org](https://pubs.acs.org)]
9. Recent Advances in the Development of Tetrazine Ligation Tools for Pretargeted Nuclear Imaging - PMC [[pmc.ncbi.nlm.nih.gov](https://pubmed.ncbi.nlm.nih.gov)]
10. Inverse Electron Demand Diels-Alder Reaction - Creative Biolabs [[creative-biolabs.com](https://www.creative-biolabs.com)]
11. [bioconjugation.bocsci.com](https://www.bioconjugation.bocsci.com) [[bioconjugation.bocsci.com](https://www.bioconjugation.bocsci.com)]
12. Strain-Promoted Azide-Alkyne Cycloaddition [[manu56.magtech.com.cn](https://www.manu56.magtech.com.cn)]
13. Strain-Promoted Alkyne-Azide Cycloadditions (SPAAC) Reveal New Features of Glycoconjugate Biosynthesis - PMC [[pmc.ncbi.nlm.nih.gov](https://pubmed.ncbi.nlm.nih.gov)]
14. [raineslab.com](https://www.raineslab.com) [[raineslab.com](https://www.raineslab.com)]

- [15. pubs.acs.org \[pubs.acs.org\]](#)
- [16. pubs.acs.org \[pubs.acs.org\]](#)
- [17. bioconjugation.bocsci.com \[bioconjugation.bocsci.com\]](#)
- [18. Staudinger Ligation Reaction Chemistry | Thermo Fisher Scientific - TR \[thermofisher.com\]](#)
- [19. pubs.acs.org \[pubs.acs.org\]](#)
- [20. Inverse electron-demand Diels–Alder reaction - Wikipedia \[en.wikipedia.org\]](#)
- [21. Tetrazine- and trans-cyclooctene-functionalised polypept\(o\)ides for fast bioorthogonal tetrazine ligation - Polymer Chemistry \(RSC Publishing\) \[pubs.rsc.org\]](#)
- To cite this document: BenchChem. [comparative analysis of bioorthogonal labeling techniques]. BenchChem, [2026]. [Online PDF]. Available at: [\[https://www.benchchem.com/product/b15580222/docs#comparative-analysis-of-bioorthogonal-labeling-techniques\]](https://www.benchchem.com/product/b15580222/docs#comparative-analysis-of-bioorthogonal-labeling-techniques)

---

### Disclaimer & Data Validity:

The information provided in this document is for Research Use Only (RUO) and is strictly not intended for diagnostic or therapeutic procedures. While BenchChem strives to provide accurate protocols, we make no warranties, express or implied, regarding the fitness of this product for every specific experimental setup.

**Technical Support:** The protocols provided are for reference purposes. Unsure if this reagent suits your experiment?

**Need Industrial/Bulk Grade?** [Request Custom Synthesis Quote](#)

## BenchChem

Our mission is to be the trusted global source of essential and advanced chemicals, empowering scientists and researchers to drive progress in science and industry.

### Contact

Address: 3281 E Guasti Rd  
Ontario, CA 91761, United States  
Phone: (601) 213-4426  
Email: [info@benchchem.com](mailto:info@benchchem.com)

Contact our Ph.D. Support Team for a compatibility check