

(R)-NVS-ZP7-4 solubility issues and solutions

Author: BenchChem Technical Support Team. **Date:** April 2026

Compound of Interest

Compound Name: (R)-NVS-ZP7-4

Cat. No.: B15579830

[Get Quote](#)

Technical Support Center: (R)-NVS-ZP7-4

Welcome to the technical support center for **(R)-NVS-ZP7-4**. This resource is designed to assist researchers, scientists, and drug development professionals in overcoming common challenges associated with the handling and use of **(R)-NVS-ZP7-4**, with a particular focus on solubility.

Frequently Asked Questions (FAQs)

Q1: What is **(R)-NVS-ZP7-4** and what is its mechanism of action?

(R)-NVS-ZP7-4 is a selective inhibitor of the zinc transporter SLC39A7, also known as ZIP7.[1] [2] ZIP7 is responsible for transporting zinc from the endoplasmic reticulum (ER) into the cytoplasm.[3] By inhibiting ZIP7, **(R)-NVS-ZP7-4** increases zinc levels in the ER, leading to ER stress and the induction of the unfolded protein response (UPR).[4][5] This compound was identified through a phenotypic screen for inhibitors of the Notch signaling pathway and has been shown to interfere with the trafficking of the Notch receptor to the cell surface.[4][6] It has been demonstrated to induce apoptosis in certain cancer cell lines, such as T-cell acute lymphoblastic leukemia (T-ALL).[2][4]

Q2: What are the recommended solvents for dissolving **(R)-NVS-ZP7-4**?

(R)-NVS-ZP7-4 is soluble in dimethyl sulfoxide (DMSO) and ethanol.[2][7] It is reported to be insoluble in water.[8]

Q3: What is the recommended storage condition for **(R)-NVS-ZP7-4**?

For long-term storage, **(R)-NVS-ZP7-4** as a solid should be stored at -20°C, protected from light, and is stable for at least four years under these conditions.[2] Stock solutions should be stored at -80°C for up to 6 months or at -20°C for up to 1 month, also protected from light.[1] It is advisable to aliquot stock solutions to avoid repeated freeze-thaw cycles.[8]

Troubleshooting Guide: Solubility Issues

Difficulties with the solubility of **(R)-NVS-ZP7-4** can often be traced to solvent quality or handling procedures. This guide provides solutions to common problems.

Issue 1: Precipitate forms after dissolving **(R)-NVS-ZP7-4** in DMSO.

- Possible Cause: The DMSO used may have absorbed moisture from the atmosphere. DMSO is highly hygroscopic, and the presence of water can significantly decrease the solubility of **(R)-NVS-ZP7-4**. [1][8]
- Solution:
 - Always use fresh, anhydrous, high-purity DMSO from a newly opened bottle.
 - If a new bottle is not available, use DMSO from a bottle that has been properly stored with desiccant.
 - Warm the solution gently (e.g., in a 37°C water bath) and sonicate to aid dissolution.

Issue 2: The compound does not fully dissolve at the desired concentration.

- Possible Cause: The desired concentration may exceed the solubility limit in the chosen solvent.
- Solution:

- Consult the solubility data table below to ensure you are working within the known solubility limits.
- Prepare a more dilute stock solution and adjust the final concentration in your experimental medium accordingly. Be mindful of the final DMSO concentration in your assay, as high concentrations can be toxic to cells.[9]

Issue 3: The compound precipitates out of the aqueous experimental medium.

- Possible Cause: **(R)-NVS-ZP7-4** has poor aqueous solubility. When a concentrated DMSO stock is diluted into an aqueous buffer or cell culture medium, the compound can crash out of solution.
- Solution:
 - Minimize the volume of the DMSO stock solution added to the aqueous medium. A final DMSO concentration of less than 0.5% is generally recommended.
 - Add the DMSO stock to the aqueous medium while vortexing or stirring to ensure rapid and even dispersion.
 - For in vivo studies, consider using a formulation with excipients that improve solubility and stability, such as a suspension with carboxymethylcellulose sodium (CMC-Na).[8]

Quantitative Solubility Data

Solvent	Reported Solubility	Molar Concentration (mM)	Source(s)
DMSO	≥ 125 mg/mL	≥ 249.19	[1]
DMSO	100 mg/mL	199.35	[8]
Ethanol	50 mg/mL	99.68	[8]
Ethanol	Soluble	Not specified	[2][7]
Water	Insoluble	Not applicable	[8]

Note: The molecular weight of **(R)-NVS-ZP7-4** is 501.6 g/mol .[2]

Experimental Protocols

Protocol 1: Preparation of a 10 mM Stock Solution in DMSO

- Materials:
 - **(R)-NVS-ZP7-4** (solid)
 - Anhydrous, high-purity DMSO
 - Sterile microcentrifuge tubes
 - Calibrated micropipettes
- Procedure:
 1. Equilibrate the vial of **(R)-NVS-ZP7-4** to room temperature before opening to prevent condensation.
 2. Weigh out the desired amount of **(R)-NVS-ZP7-4**. For example, to prepare 1 mL of a 10 mM stock solution, weigh out 5.016 mg.
 3. Add the appropriate volume of fresh, anhydrous DMSO to the solid compound.
 4. Vortex the solution until the solid is completely dissolved. Gentle warming (37°C) and brief sonication may be used to facilitate dissolution.
 5. Aliquot the stock solution into smaller volumes in sterile, light-protected tubes to minimize freeze-thaw cycles.
 6. Store the aliquots at -80°C.

Protocol 2: Preparation of an In Vivo Formulation (Homogeneous Suspension)

This protocol is adapted from a general method for oral administration of hydrophobic compounds.[8]

- Materials:
 - **(R)-NVS-ZP7-4** (solid)
 - Carboxymethylcellulose sodium (CMC-Na)
 - Sterile water for injection
 - Homogenizer or sonicator
- Procedure:
 1. Prepare a 0.5% (w/v) solution of CMC-Na in sterile water. For example, add 50 mg of CMC-Na to 10 mL of sterile water and stir until fully dissolved. Autoclave the solution to ensure sterility.
 2. Weigh the required amount of **(R)-NVS-ZP7-4**.
 3. Add the CMC-Na solution to the solid compound to achieve the desired final concentration (e.g., 5 mg/mL).[8]
 4. Homogenize or sonicate the mixture until a uniform suspension is formed.
 5. It is recommended to prepare this formulation fresh on the day of use.[10]

Visualizations

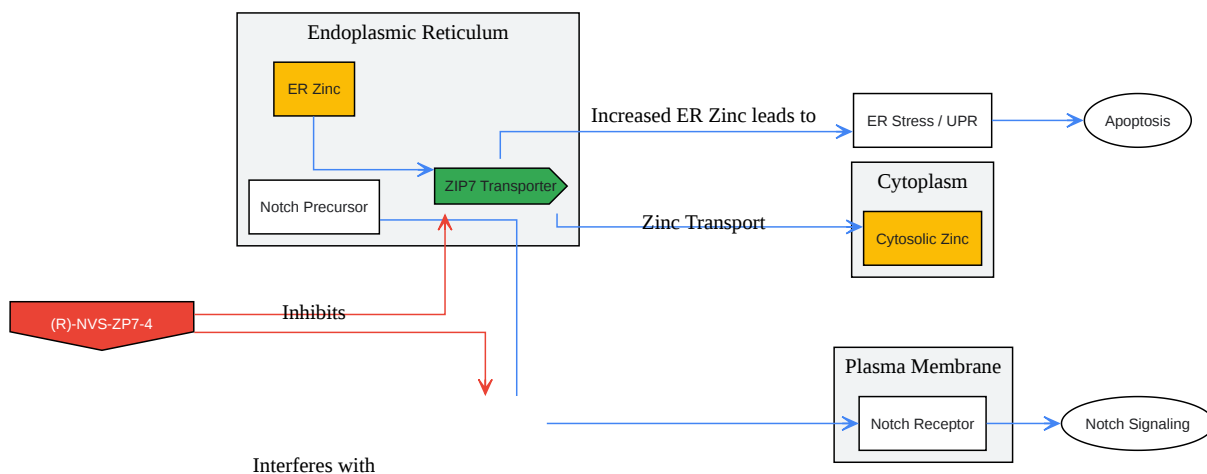

[Click to download full resolution via product page](#)

Caption: Mechanism of action of **(R)-NVS-ZP7-4**.

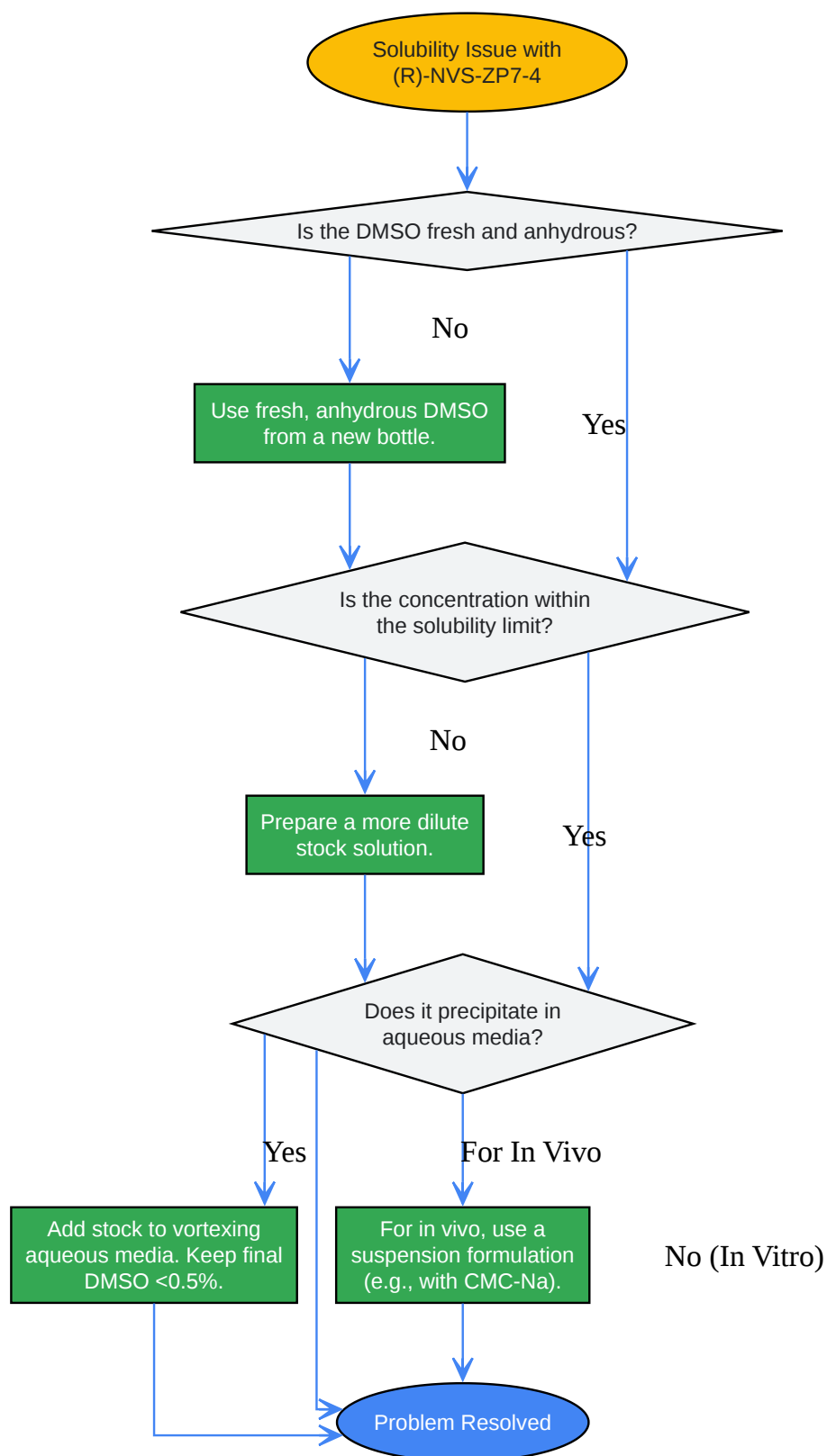

[Click to download full resolution via product page](#)

Caption: Troubleshooting workflow for solubility issues.

Need Custom Synthesis?

BenchChem offers custom synthesis for rare earth carbides and specific isotopic labeling.

Email: info@benchchem.com or [Request Quote Online](#).

References

- [1. medchemexpress.com \[medchemexpress.com\]](https://www.medchemexpress.com)
- [2. cdn.caymanchem.com \[cdn.caymanchem.com\]](https://www.cdn.caymanchem.com)
- [3. The Zinc Transporter SLC39A7 \(ZIP7\) Is Essential for Regulation of Cytosolic Zinc Levels - PubMed \[pubmed.ncbi.nlm.nih.gov\]](https://pubmed.ncbi.nlm.nih.gov/)
- [4. Discovery of a ZIP7 inhibitor from a Notch pathway screen - PMC \[pmc.ncbi.nlm.nih.gov\]](https://pubmed.ncbi.nlm.nih.gov/)
- [5. researchgate.net \[researchgate.net\]](https://www.researchgate.net)
- [6. Discovery of a ZIP7 inhibitor from a Notch pathway screen. | BioFrontiers Institute | University of Colorado Boulder \[colorado.edu\]](https://www.biofrontiers.org/)
- [7. caymanchem.com \[caymanchem.com\]](https://www.caymanchem.com)
- [8. selleckchem.com \[selleckchem.com\]](https://www.selleckchem.com)
- [9. Unexpected low-dose toxicity of the universal solvent DMSO - PubMed \[pubmed.ncbi.nlm.nih.gov\]](https://pubmed.ncbi.nlm.nih.gov/)
- [10. medchemexpress.com \[medchemexpress.com\]](https://www.medchemexpress.com)
- To cite this document: BenchChem. [(R)-NVS-ZP7-4 solubility issues and solutions]. BenchChem, [2026]. [Online PDF]. Available at: [\[https://www.benchchem.com/product/b15579830/docs#r-nvs-zp7-4-solubility-issues-and-solutions\]](https://www.benchchem.com/product/b15579830/docs#r-nvs-zp7-4-solubility-issues-and-solutions)

Disclaimer & Data Validity:

The information provided in this document is for Research Use Only (RUO) and is strictly not intended for diagnostic or therapeutic procedures. While BenchChem strives to provide accurate protocols, we make no warranties, express or implied, regarding the fitness of this product for every specific experimental setup.

Technical Support: The protocols provided are for reference purposes. Unsure if this reagent suits your experiment?

Need Industrial/Bulk Grade? [Request Custom Synthesis Quote](#)

BenchChem

Our mission is to be the trusted global source of essential and advanced chemicals, empowering scientists and researchers to drive progress in science and industry.

Contact

Address: 3281 E Guasti Rd
Ontario, CA 91761, United States
Phone: (601) 213-4426
Email: info@benchchem.com

[Contact our Ph.D. Support Team for a compatibility check](#)