

# A Comparative Guide to the Degradation Efficiency of Pomalidomide-Based PROTACs

**Author:** BenchChem Technical Support Team. **Date:** April 2026

## Compound of Interest

Compound Name: Pomalidomide-CO-C3-PEG4-C6-NH2  
Cat. No.: B15578418

[Get Quote](#)

For Researchers, Scientists, and Drug Development Professionals

This guide provides a comprehensive comparison of the degradation efficiency, specifically the half-maximal degradation concentration (DC50) and maximum degradation (Dmax), of various Pomalidomide-based Proteolysis Targeting Chimeras (PROTACs). Pomalidomide, a well-established ligand for the Cereblon (CRBN) E3 ubiquitin ligase, serves as a crucial component in the design of these heterobifunctional molecules that induce targeted protein degradation. This document summarizes key experimental data, provides detailed methodologies for relevant assays, and visualizes the underlying biological pathways and experimental processes.

## Comparative Degradation Efficiency of Pomalidomide PROTACs

The efficacy of Pomalidomide-based PROTACs is primarily evaluated by their ability to induce the degradation of a target protein. This is quantified by the DC50 value, representing the concentration of the PROTAC that achieves 50% degradation of the target protein, and the

Dmax value, which indicates the maximum percentage of protein degradation achievable. Lower DC50 values are indicative of higher potency.

The following tables summarize the degradation efficiencies of several Pomalidomide-based PROTACs against a range of therapeutically relevant protein targets.

Target Protein	PROTAC Compound	Cell Line	DC50 (nM)	Dmax (%)	Reference
HDAC8	ZQ-23	Not Specified	147	93	[1][2]
ALK	MS4078 (C4-alkyne)	SU-DHL-1	~50	>90	[3]
ALK	dALK-2 (C5-alkyne)	SU-DHL-1	~10	>95	[3]
BCR-ABL	Compound 30 (SIAIS100)	K562	2.7	91.2	
BCR-ABL	PROTAC35	Not Specified	340	>95	[4]
BCL-XL	PROTAC171	MOLT-4	63	90.8	[4]
EGFR	Compound 15	A549	43.4	86	
EGFR	Compound 16	A549	32.9	96	
CDK2	Compound 74	PC-3	62	Not Reported	[4]
CDK9	Compound 74	PC-3	33	Not Reported	[4]

## Experimental Protocols

Accurate determination of DC50 and Dmax values is critical for the evaluation and comparison of PROTAC efficacy. The following are detailed protocols for key experiments.

## Western Blotting for DC50 and Dmax Determination

This is a standard method to quantify the dose-dependent degradation of a target protein.

### a. Cell Culture and Treatment:

- Seed cells at an appropriate density in multi-well plates and allow them to adhere overnight.
- Treat the cells with a serial dilution of the Pomalidomide-based PROTAC for a predetermined time (e.g., 24 hours). Include a vehicle control (e.g., DMSO).

### b. Cell Lysis:

- After treatment, wash the cells with ice-cold phosphate-buffered saline (PBS).
- Lyse the cells in radioimmunoprecipitation assay (RIPA) buffer supplemented with protease and phosphatase inhibitors.
- Scrape the cells and collect the lysate.
- Centrifuge the lysate at high speed at 4°C to pellet cell debris.
- Collect the supernatant containing the protein extract.

### c. Protein Quantification:

- Determine the protein concentration of each lysate using a bicinchoninic acid (BCA) assay or a similar protein quantification method to ensure equal loading.

### d. SDS-PAGE and Western Blotting:

- Normalize the protein samples to the same concentration with lysis buffer and Laemmli buffer.
- Denature the samples by heating.
- Separate the proteins by sodium dodecyl sulfate-polyacrylamide gel electrophoresis (SDS-PAGE).

- Transfer the separated proteins to a polyvinylidene fluoride (PVDF) or nitrocellulose membrane.
- Block the membrane with 5% non-fat milk or bovine serum albumin (BSA) in Tris-buffered saline with Tween 20 (TBST) for 1 hour at room temperature.
- Incubate the membrane with a primary antibody specific to the target protein overnight at 4°C.
- Wash the membrane with TBST.
- Incubate with a horseradish peroxidase (HRP)-conjugated secondary antibody for 1 hour at room temperature.
- Wash the membrane again with TBST.
- Visualize the protein bands using an enhanced chemiluminescence (ECL) substrate and an imaging system.
- To ensure equal protein loading, the membrane can be stripped and re-probed with an antibody against a loading control protein (e.g., GAPDH,  $\beta$ -actin, or  $\beta$ -tubulin).

e. Data Analysis:

- Quantify the band intensities using image analysis software.
- Normalize the intensity of the target protein band to the intensity of the corresponding loading control band.
- Calculate the percentage of protein remaining for each PROTAC concentration relative to the vehicle control.
- Plot the percentage of remaining protein against the logarithm of the PROTAC concentration and fit the data to a dose-response curve (e.g., a four-parameter logistic model) to determine the DC50 and Dmax values.

## In-Cell Ubiquitination Assay

This assay confirms that the PROTAC-mediated protein degradation occurs via the ubiquitin-proteasome system.

a. Cell Treatment:

- Treat cells with the Pomalidomide-based PROTAC at a concentration known to induce significant degradation (e.g., 5-10 times the DC50).
- In a parallel set of wells, co-treat cells with the PROTAC and a proteasome inhibitor (e.g., 10  $\mu$ M MG132) for 4-6 hours. The proteasome inhibitor will block the degradation of ubiquitinated proteins, allowing them to accumulate.

b. Cell Lysis:

- Lyse the cells in a buffer containing deubiquitinase inhibitors (e.g., N-ethylmaleimide (NEM) or PR-619) to preserve the ubiquitinated state of the proteins.

c. Immunoprecipitation:

- Incubate the cell lysates with a primary antibody against the target protein overnight at 4°C.
- Add Protein A/G magnetic beads to pull down the antibody-protein complex.
- Wash the beads to remove non-specific binding.
- Elute the immunoprecipitated protein from the beads.

d. Western Blotting:

- Separate the eluted proteins by SDS-PAGE and transfer them to a membrane.
- Probe the membrane with a primary antibody that recognizes ubiquitin (e.g., P4D1 or FK2).
- A ladder or smear of high-molecular-weight bands in the lanes from cells treated with the PROTAC and the proteasome inhibitor indicates polyubiquitination of the target protein.

## Visualizations: Pathways and Workflows

## Mechanism of Pomalidomide PROTAC-Induced Protein Degradation

Pomalidomide-based PROTACs function by forming a ternary complex between the target protein and the CRBN E3 ubiquitin ligase. This proximity facilitates the transfer of ubiquitin molecules to the target protein, marking it for degradation by the 26S proteasome.

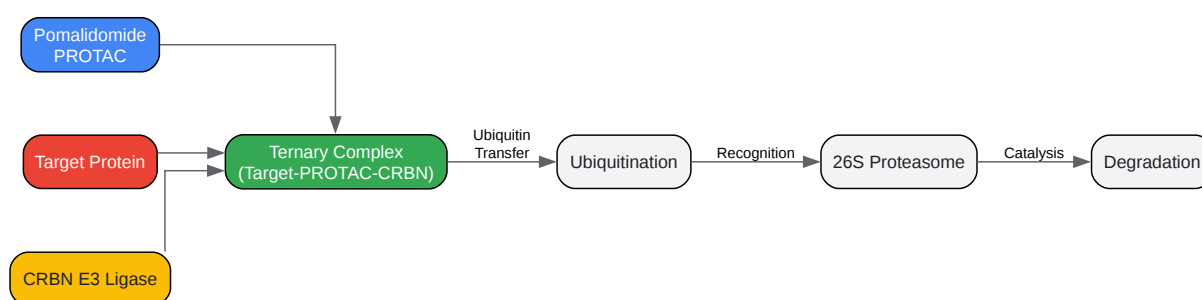

[Click to download full resolution via product page](#)

Caption: Mechanism of Pomalidomide PROTAC action.

## Experimental Workflow for PROTAC Evaluation

The evaluation of a novel PROTAC typically follows a structured workflow to assess its degradation capability and mechanism of action.

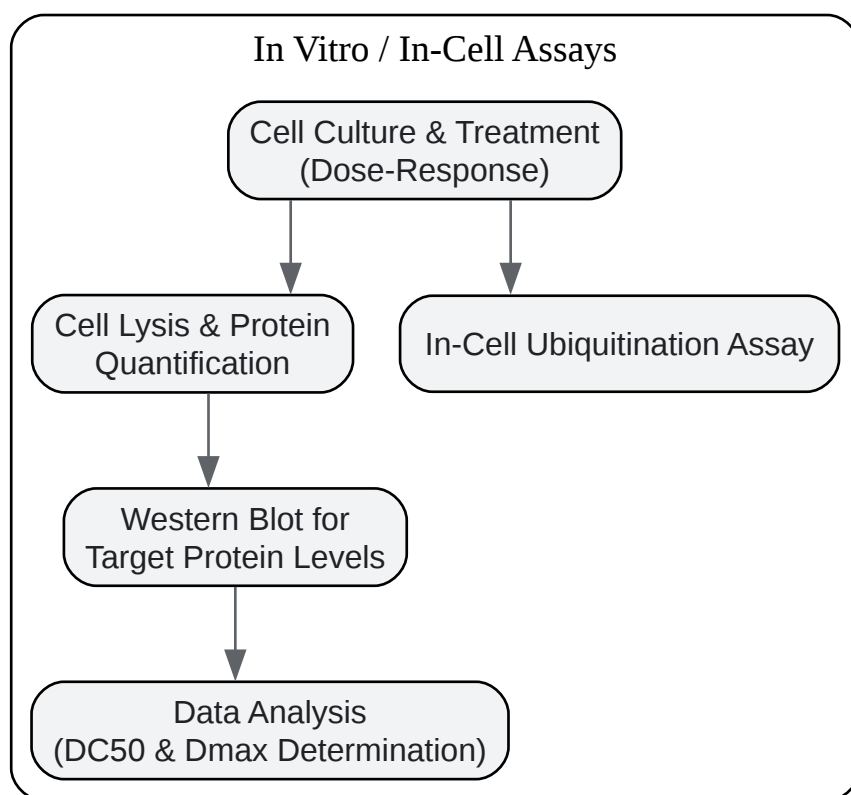

[Click to download full resolution via product page](#)

Caption: Experimental workflow for PROTAC evaluation.

## Signaling Pathways of Target Proteins

Understanding the signaling pathways in which the target proteins are involved is crucial for predicting the functional consequences of their degradation.

### HDAC8 Signaling

HDAC8 is a class I histone deacetylase that regulates the expression of various genes involved in cell cycle progression and apoptosis by deacetylating histone and non-histone proteins.

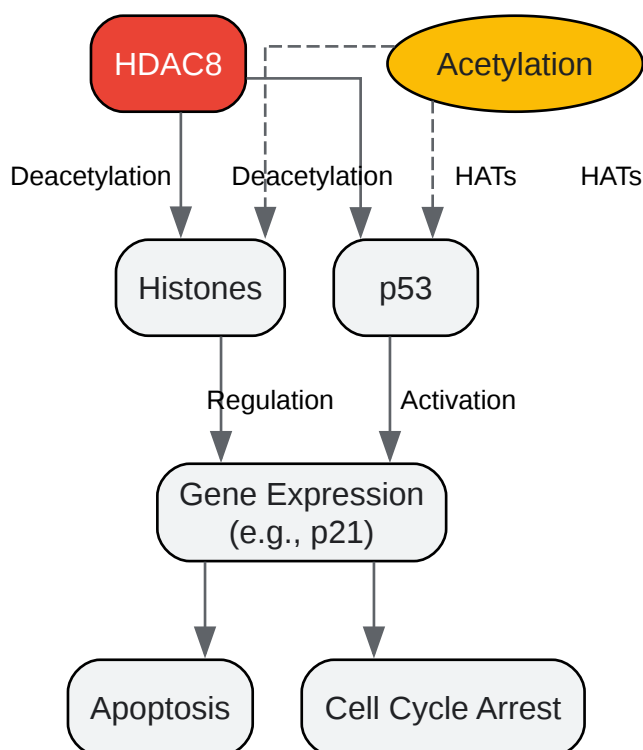

[Click to download full resolution via product page](#)

Caption: Simplified HDAC8 signaling pathway.

## ALK Signaling

Anaplastic lymphoma kinase (ALK) is a receptor tyrosine kinase that, when constitutively activated (e.g., through chromosomal rearrangement), drives cell proliferation and survival through downstream pathways like PI3K/AKT and RAS/MAPK.

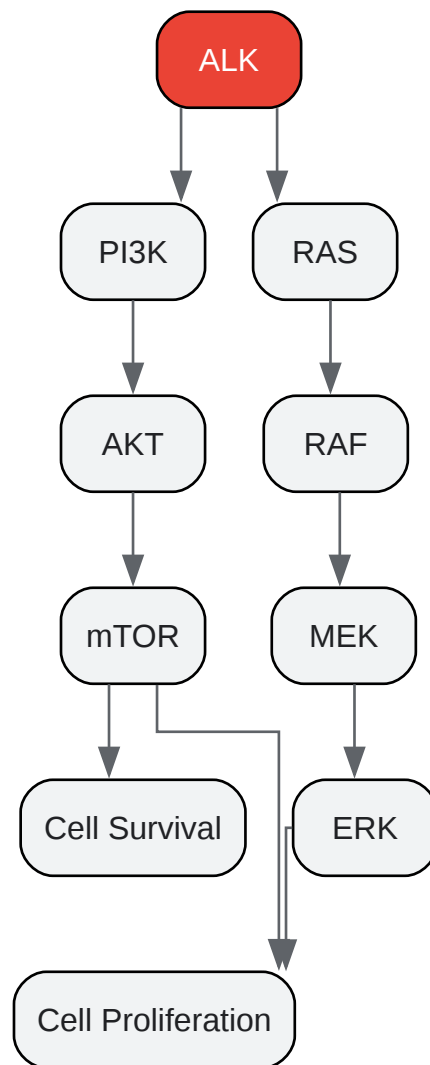

[Click to download full resolution via product page](#)

Caption: Key ALK signaling pathways in cancer.

### BCR-ABL Signaling

The BCR-ABL fusion protein is a constitutively active tyrosine kinase that is the hallmark of chronic myeloid leukemia (CML). It activates multiple signaling pathways, including the JAK/STAT and RAS/MAPK pathways, leading to uncontrolled cell proliferation and inhibition of apoptosis.

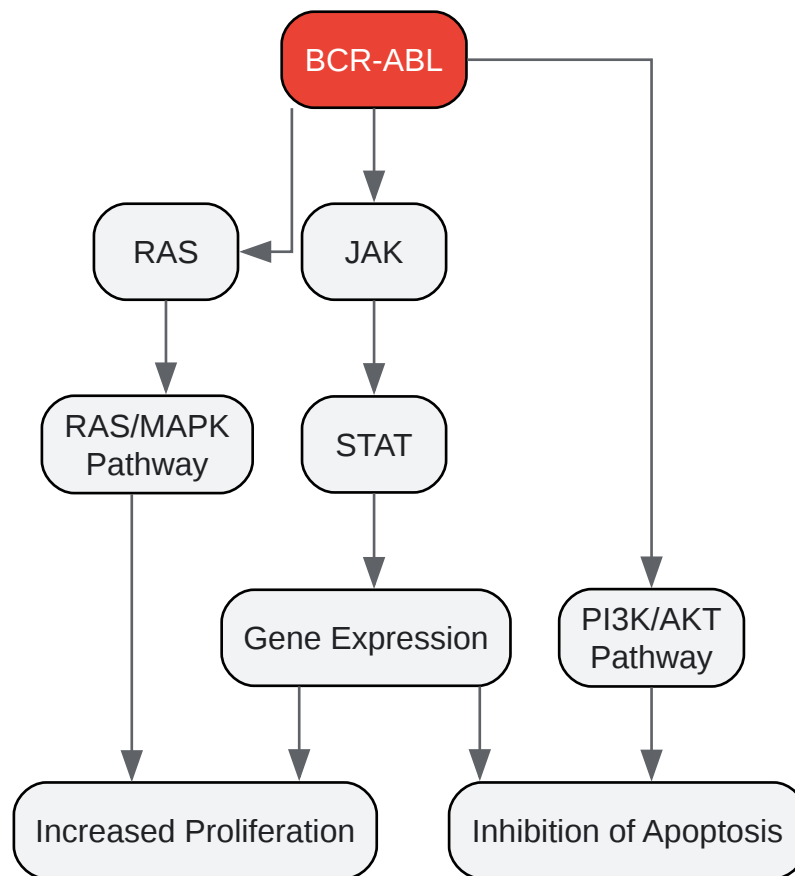

[Click to download full resolution via product page](#)

Caption: Major BCR-ABL signaling pathways.

### BCL-XL Signaling

BCL-XL is an anti-apoptotic protein that prevents the release of cytochrome c from the mitochondria, thereby inhibiting the intrinsic pathway of apoptosis.

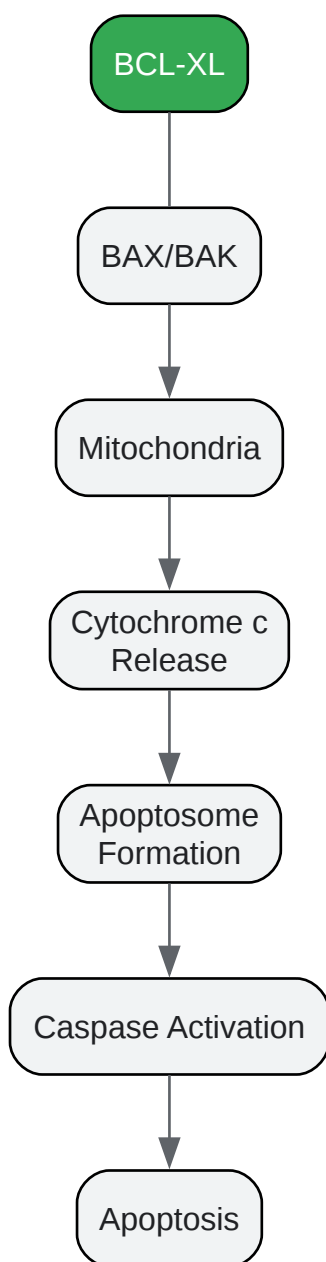

[Click to download full resolution via product page](#)

Caption: BCL-XL's role in the intrinsic apoptosis pathway.

### EGFR Signaling

The epidermal growth factor receptor (EGFR) is a receptor tyrosine kinase that, upon activation by its ligands, initiates downstream signaling cascades such as the RAS/MAPK and PI3K/AKT pathways, which are critical for cell growth and proliferation.

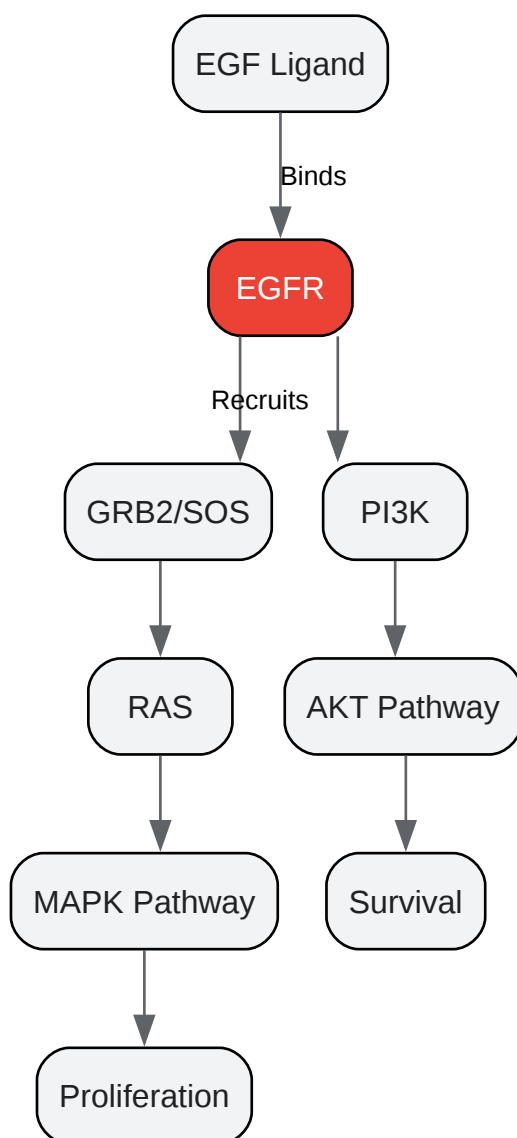

[Click to download full resolution via product page](#)

Caption: Overview of the EGFR signaling pathway.

### ***Need Custom Synthesis?***

*BenchChem offers custom synthesis for rare earth carbides and specific isotopic labeling.*

*Email: [info@benchchem.com](mailto:info@benchchem.com) or [Request Quote Online](#).*

## References

- 1. 表皮生长因子受体 (EGFR) 信号传导 [[sigmaaldrich.cn](http://sigmaaldrich.cn)]
- 2. Molecular pathways: BCR-ABL - PubMed [[pubmed.ncbi.nlm.nih.gov](http://pubmed.ncbi.nlm.nih.gov)]
- 3. [lifesciences.danaher.com](http://lifesciences.danaher.com) [[lifesciences.danaher.com](http://lifesciences.danaher.com)]
- 4. [researchgate.net](http://researchgate.net) [[researchgate.net](http://researchgate.net)]
- To cite this document: BenchChem. [A Comparative Guide to the Degradation Efficiency of Pomalidomide-Based PROTACs]. BenchChem, [2026]. [Online PDF]. Available at: [<https://www.benchchem.com/product/b15578418/docs#a-comparative-guide-to-the-degradation-efficiency-of-pomalidomide-based-protacs>]

---

### Disclaimer & Data Validity:

The information provided in this document is for Research Use Only (RUO) and is strictly not intended for diagnostic or therapeutic procedures. While BenchChem strives to provide accurate protocols, we make no warranties, express or implied, regarding the fitness of this product for every specific experimental setup.

**Technical Support:** The protocols provided are for reference purposes. Unsure if this reagent suits your experiment?

**Need Industrial/Bulk Grade?** [Request Custom Synthesis Quote](#)

## BenchChem

Our mission is to be the trusted global source of essential and advanced chemicals, empowering scientists and researchers to drive progress in science and industry.

### Contact

Address: 3281 E Guasti Rd  
Ontario, CA 91761, United States  
Phone: (601) 213-4426  
Email: [info@benchchem.com](mailto:info@benchchem.com)

[Contact our Ph.D. Support Team for a compatibility check](#)

