

The Pro-Efferocytic Agent VU533: A Comparative Analysis

Author: BenchChem Technical Support Team. **Date:** April 2026

Compound of Interest

Compound Name: VU533
Cat. No.: B15577627

[Get Quote](#)

A note to our readers: Initial searches for the compound "**VU533**" did not yield specific information regarding its pro-efferocytic effects. This suggests that "**VU533**" may be an internal designation not yet in the public domain, a potential misnomer, or a compound that has not been characterized for this specific activity. To fulfill the spirit of the requested guide, we have focused on a well-documented pro-efferocytic agent, the SHP-1 inhibitor NSC-87877, and will compare its activity to other known classes of efferocytosis-promoting compounds. This guide is intended for researchers, scientists, and drug development professionals interested in the therapeutic potential of enhancing efferocytosis.

Introduction to Efferocytosis and its Therapeutic Potential

Efferocytosis is the process by which apoptotic (dying) cells are recognized and removed by phagocytic cells, primarily macrophages. This process is crucial for tissue homeostasis, resolution of inflammation, and prevention of autoimmune responses. Dysfunctional efferocytosis is implicated in a variety of chronic inflammatory diseases, including atherosclerosis, chronic obstructive pulmonary disease (COPD), and autoimmune disorders like systemic lupus erythematosus (SLE). Consequently, therapeutic strategies aimed at enhancing efferocytosis are of significant interest.

This guide provides a comparative overview of the SHP-1 inhibitor NSC-87877 and other classes of pro-efferocytic agents, including Liver X Receptor (LXR) agonists, Peroxisome Proliferator-Activated Receptor-gamma (PPAR γ) agonists, and agents that block the CD47-SIRP α "don't eat me" signaling axis.

Comparative Efficacy of Pro-Efferocytic Agents

The following table summarizes the quantitative effects of various pro-efferocytic agents on macrophage-mediated efferocytosis, as reported in the literature. It is important to note that direct head-to-head comparisons are limited, and experimental conditions vary between studies.

Compound Class	Representative Agent	Efferocytosis Metric	Fold/Percent Change	Cell Type	Reference
SHP-1 Inhibitor	NSC-87877 (or genetic loss-of-function)	Phagocytic Index	2-3 fold increase	Mouse Bone Marrow-Derived Macrophages	
LXR Agonist	GW3965	% of F4/80+ cells with phagocytosed apoptotic cells	~43% to ~82% (increase)	Mouse Peritoneal Macrophages	[1]
PPAR γ Agonist	Rosiglitazone	Phagocytic Activity	Significant increase	Rat Primary Microglia	
Anti-CD47 Antibody	Anti-CD47 mAb	Phagocytosis of myeloma cells	Significant increase	Macrophages	[2]

Signaling Pathways of Pro-Efferocytic Agents

The mechanisms by which these compounds enhance efferocytosis differ, targeting various points in the signaling cascade that governs apoptotic cell recognition and engulfment.

SHP-1 Inhibition

SHP-1 is a protein tyrosine phosphatase that acts as a negative regulator of phagocytosis downstream of the CD47-SIRP α signaling axis. Inhibition of SHP-1 relieves this braking mechanism, thereby promoting efferocytosis.[3][4][5]

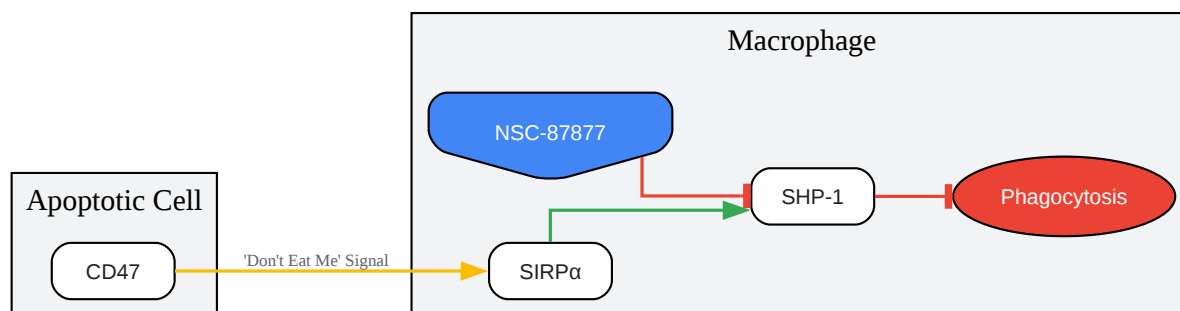

[Click to download full resolution via product page](#)

SHP-1 Inhibition Pathway

LXR and PPAR γ Agonism

LXR and PPAR γ are nuclear receptors that, upon activation by their respective agonists, translocate to the nucleus and induce the transcription of genes involved in efferocytosis.[6] A key target gene is the receptor tyrosine kinase MerTK, which plays a critical role in the recognition and engulfment of apoptotic cells.

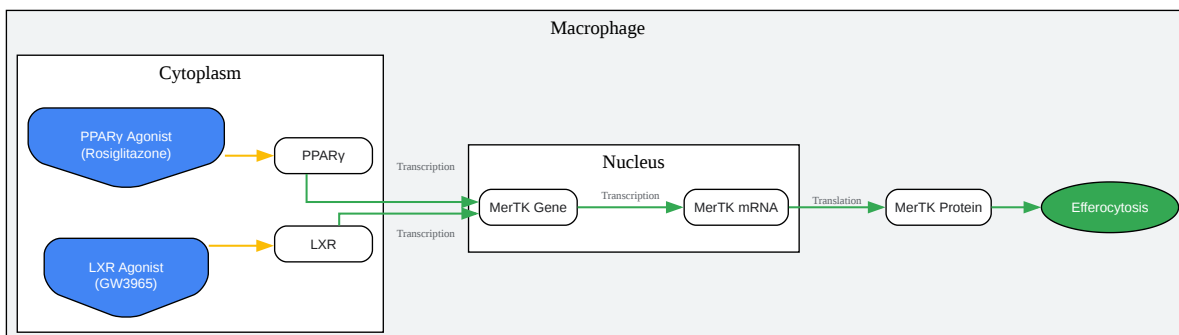

[Click to download full resolution via product page](#)

Nuclear Receptor Agonist Pathway

CD47-SIRPα Blockade

CD47 on the surface of cells interacts with SIRPα on macrophages to transmit a "don't eat me" signal, which inhibits phagocytosis.[7] Anti-CD47 antibodies physically block this interaction, thereby promoting the engulfment of apoptotic cells.



[Click to download full resolution via product page](#)

CD47-SIRPα Blockade Pathway

Experimental Protocols

A variety of in vitro and in vivo assays are used to quantify efferocytosis. Below are generalized protocols for commonly used in vitro methods.

In Vitro Efferocytosis Assay (Flow Cytometry-Based)

This method allows for the high-throughput quantification of apoptotic cell engulfment by macrophages.

1. Preparation of Macrophages:

- Culture macrophage cell lines (e.g., J774A.1, RAW264.7) or differentiate primary monocytes into macrophages in appropriate culture plates.
- For some protocols, macrophages can be labeled with a fluorescent dye (e.g., CFSE) for easy identification.

2. Preparation of Apoptotic Target Cells:

- Use a cell line that can be easily induced to undergo apoptosis (e.g., Jurkat T cells).
- Induce apoptosis using methods such as UV irradiation or treatment with staurosporine.
- Label the apoptotic cells with a pH-sensitive fluorescent dye (e.g., pHrodo Red) or a viability dye (e.g., Calcein AM) prior to apoptosis induction.

3. Co-culture and Efferocytosis:

- Add the labeled apoptotic cells to the macrophage culture at a specific ratio (e.g., 5:1 apoptotic cells to macrophages).
- Co-incubate for a defined period (e.g., 1-2 hours) at 37°C to allow for efferocytosis.

4. Sample Preparation and Analysis:

- Gently wash the cells to remove non-engulfed apoptotic cells.
- Detach the macrophages from the plate using a non-enzymatic cell dissociation solution.

- Analyze the cell suspension by flow cytometry. Macrophages that have engulfed apoptotic cells will show a fluorescent signal from the labeled apoptotic cells.
- The percentage of fluorescent macrophages represents the efferocytosis rate or phagocytic index.

In Vitro Efferocytosis Assay (Microscopy-Based)

This method provides visual confirmation of efferocytosis and allows for the quantification of engulfed cells per macrophage.

1. Preparation of Cells:

- Seed macrophages on glass coverslips in a culture plate.
- Prepare and label apoptotic cells with a fluorescent dye as described for the flow cytometry assay.

2. Co-culture and Efferocytosis:

- Add the labeled apoptotic cells to the macrophages on coverslips and co-incubate.

3. Staining and Imaging:

- After incubation, wash the coverslips to remove non-engulfed cells.
- Fix the cells with paraformaldehyde.
- Optionally, stain the macrophages with a counterstain (e.g., DAPI for nuclei, or an antibody against a macrophage marker like F4/80).
- Mount the coverslips on microscope slides.
- Image the cells using a fluorescence microscope.

4. Quantification:

- Count the number of macrophages that have internalized fluorescent apoptotic bodies.

- Count the total number of macrophages in the field of view.
- The phagocytic index can be calculated as: $(\text{Number of macrophages with engulfed cells} / \text{Total number of macrophages}) \times 100$.

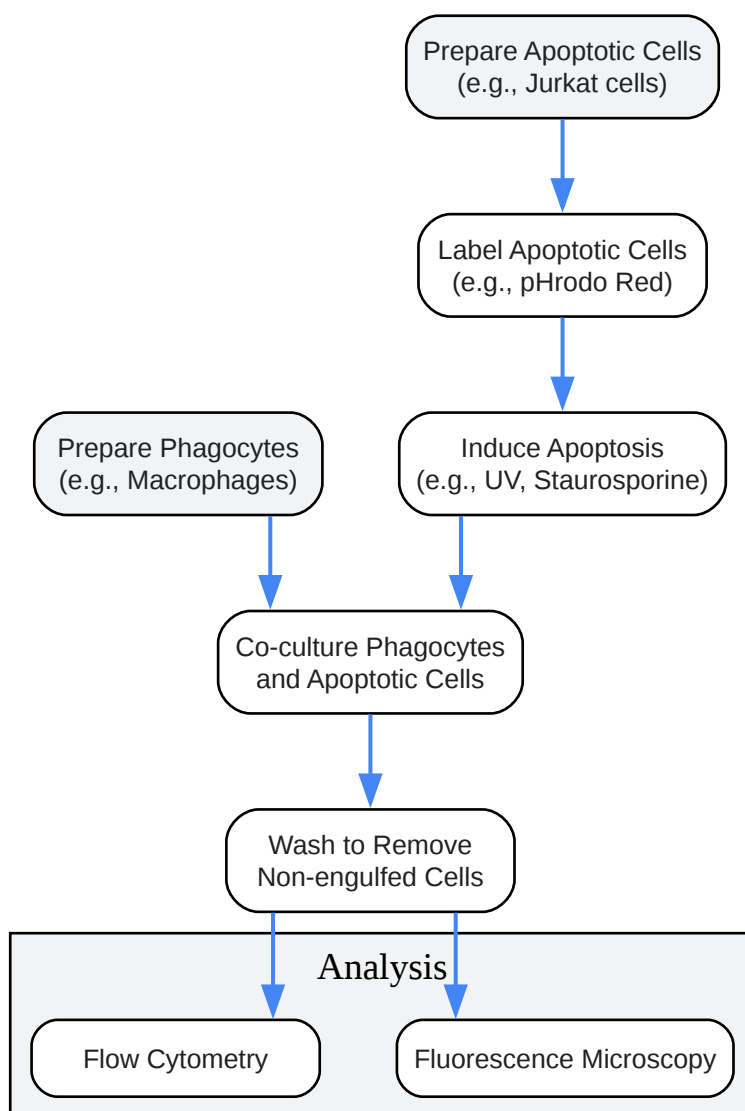

[Click to download full resolution via product page](#)

Need Custom Synthesis?

BenchChem offers custom synthesis for rare earth carbides and specific isotopic labeling.

Email: info@benchchem.com or [Request Quote Online](#).

References

- 1. Protective Functions of Liver X Receptor α in Established Vulnerable Plaques: Involvement of Regulating Endoplasmic Reticulum–Mediated Macrophage Apoptosis and Efferocytosis - PMC [[pmc.ncbi.nlm.nih.gov](https://pubmed.ncbi.nlm.nih.gov/)]
- 2. Anti-CD47 antibodies promote phagocytosis and inhibit the growth of human myeloma cells - PubMed [pubmed.ncbi.nlm.nih.gov]
- 3. CD47 promotes autoimmune valvular carditis by impairing macrophage efferocytosis and enhancing cytokine production - PMC [[pmc.ncbi.nlm.nih.gov](https://pubmed.ncbi.nlm.nih.gov/)]
- 4. Pro-efferocytic macrophage membrane biomimetic nanoparticles for the synergistic treatment of atherosclerosis via competition effect - PMC [[pmc.ncbi.nlm.nih.gov](https://pubmed.ncbi.nlm.nih.gov/)]
- 5. Pro-efferocytic nanoparticles are specifically taken up by lesional macrophages and prevent atherosclerosis - PMC [[pmc.ncbi.nlm.nih.gov](https://pubmed.ncbi.nlm.nih.gov/)]
- 6. Efferocytosis signaling in the regulation of macrophage inflammatory responses - PMC [[pmc.ncbi.nlm.nih.gov](https://pubmed.ncbi.nlm.nih.gov/)]
- 7. CD47–SIRP α -targeted therapeutics: status and prospects - PMC [[pmc.ncbi.nlm.nih.gov](https://pubmed.ncbi.nlm.nih.gov/)]
- To cite this document: BenchChem. [The Pro-Efferocytic Agent VU533: A Comparative Analysis]. BenchChem, [2026]. [Online PDF]. Available at: [<https://www.benchchem.com/product/b15577627/docs#the-pro-efferocytic-agent-vu533-a-comparative-analysis>]

Disclaimer & Data Validity:

The information provided in this document is for Research Use Only (RUO) and is strictly not intended for diagnostic or therapeutic procedures. While BenchChem strives to provide accurate protocols, we make no warranties, express or implied, regarding the fitness of this product for every specific experimental setup.

Technical Support: The protocols provided are for reference purposes. Unsure if this reagent suits your experiment?

Need Industrial/Bulk Grade? [Request Custom Synthesis Quote](#)

BenchChem

Our mission is to be the trusted global source of essential and advanced chemicals, empowering scientists and researchers to drive progress in science and industry.

Contact

Address: 3281 E Guasti Rd

Ontario, CA 91761, United States

Phone: (601) 213-4426

Email: info@benchchem.com

[Contact our Ph.D. Support Team for a compatibility check](#)