

# Application Notes: Synthesis of VH032-Thiol-C6-NH2 Conjugate for PROTAC Development

**Author:** BenchChem Technical Support Team. **Date:** April 2026

## Compound of Interest

Compound Name: VH032-thiol-C6-NH2

Cat. No.: B15577031

[Get Quote](#)

## Introduction

Proteolysis-targeting chimeras (PROTACs) are heterobifunctional molecules that represent a novel therapeutic modality for targeted protein degradation.<sup>[1][2][3]</sup> A PROTAC consists of a ligand that binds to a target protein of interest and another ligand that recruits an E3 ubiquitin ligase, joined by a chemical linker.<sup>[1][2][3]</sup> This proximity induces the ubiquitination and subsequent degradation of the target protein by the proteasome. The von Hippel-Lindau (VHL) E3 ligase is frequently utilized in PROTAC design due to the availability of potent small molecule ligands, such as VH032.<sup>[1][2]</sup>

This document provides detailed protocols for the conjugation of a carboxylated derivative of the VHL ligand VH032 with a bifunctional thiol-C6-amine linker (HS-(CH<sub>2</sub>)<sub>6</sub>-NH<sub>2</sub>). The resulting conjugate, **VH032-thiol-C6-NH<sub>2</sub>**, is a key intermediate in the synthesis of PROTACs, where the terminal thiol group is available for conjugation to a ligand for a target protein of interest. The primary method described is an amide bond formation facilitated by the coupling agent HATU.

## Principle of Conjugation

The conjugation of a carboxylated VH032 derivative (VH032-acid) to the thiol-C6-NH<sub>2</sub> linker is achieved through the formation of a stable amide bond. The reaction is typically mediated by a

peptide coupling agent, such as HATU (1-[Bis(dimethylamino)methylene]-1H-1,2,3-triazolo[4,5-b]pyridinium 3-oxid hexafluorophosphate), in the presence of a non-nucleophilic base like N,N-diisopropylethylamine (DIPEA). HATU activates the carboxylic acid of VH032, making it susceptible to nucleophilic attack by the primary amine of the linker.

## Materials and Reagents

- VH032-acid derivative (e.g., (S,R,S)-AHPC-CO-C6-COOH)
- Thiol-C6-NH2 linker (6-aminohexane-1-thiol)
- HATU (Hexafluorophosphate Azabenzotriazole Tetramethyl Uronium)
- DIPEA (N,N-Diisopropylethylamine)
- Anhydrous Dimethylformamide (DMF)
- Dichloromethane (DCM)
- Methanol (MeOH)
- Ethyl Acetate (EtOAc)
- Saturated aqueous sodium bicarbonate ( $\text{NaHCO}_3$ )
- Brine (saturated aqueous NaCl)
- Anhydrous sodium sulfate ( $\text{Na}_2\text{SO}_4$ )
- High-Performance Liquid Chromatography (HPLC) system
- Mass Spectrometer (MS)
- Standard laboratory glassware and magnetic stirrer

## Data Presentation

### Table 1: Starting Material Specifications

Compound	Molecular Weight (g/mol)	Purity	Source
VH032-acid	Varies by linker	>95%	Synthesized or Commercial
Thiol-C6-NH2	133.26	>95%	Commercial
VH032 Amine Precursor	488.04 (HCl salt)	97%	Synthesized[4]

## Table 2: Representative Reaction Parameters and Outcomes

Parameter	Value	Notes
Reactants Ratio		
VH032-acid	1.0 eq	Limiting reagent
Thiol-C6-NH2	1.2 eq	Slight excess to ensure complete consumption of VH032-acid
HATU	1.2 eq	Coupling agent
DIPEA	3.0 eq	Base
Reaction Conditions		
Solvent	Anhydrous DMF	
Temperature	Room Temperature (20-25 °C)	
Reaction Time	12-18 hours	Monitored by LC-MS
Yield and Purity		
Crude Yield	>85%	
Purified Yield	60-75%	After HPLC purification
Final Purity	>97%	Determined by HPLC

## Experimental Protocols

### Protocol 1: HATU-Mediated Amide Coupling

This protocol describes the conjugation of a VH032-acid derivative with the Thiol-C6-NH<sub>2</sub> linker.

- Preparation:
  - In a flame-dried round-bottom flask under an inert atmosphere (e.g., argon or nitrogen), dissolve the VH032-acid derivative (1.0 eq) in anhydrous DMF.
  - Add HATU (1.2 eq) to the solution and stir for 5 minutes.
  - Add DIPEA (3.0 eq) to the reaction mixture and stir for another 10 minutes at room temperature.
- Reaction:
  - In a separate vial, dissolve the Thiol-C6-NH<sub>2</sub> linker (1.2 eq) in a small amount of anhydrous DMF.
  - Add the linker solution dropwise to the activated VH032-acid mixture.
  - Allow the reaction to stir at room temperature for 12-18 hours.
  - Monitor the reaction progress by LC-MS to confirm the formation of the desired product and consumption of the starting material.
- Work-up:
  - Once the reaction is complete, dilute the mixture with ethyl acetate.
  - Wash the organic layer sequentially with saturated aqueous NaHCO<sub>3</sub> (2x) and brine (1x).
  - Dry the organic layer over anhydrous Na<sub>2</sub>SO<sub>4</sub>, filter, and concentrate under reduced pressure to obtain the crude product.
- Purification:

- Purify the crude product using reverse-phase preparative HPLC to obtain the highly pure **VH032-thiol-C6-NH2** conjugate.
- Characterization:
  - Confirm the identity and purity of the final product using LC-MS and  $^1\text{H}$  NMR. The expected mass corresponding to the conjugated product should be observed.

## Visualizations

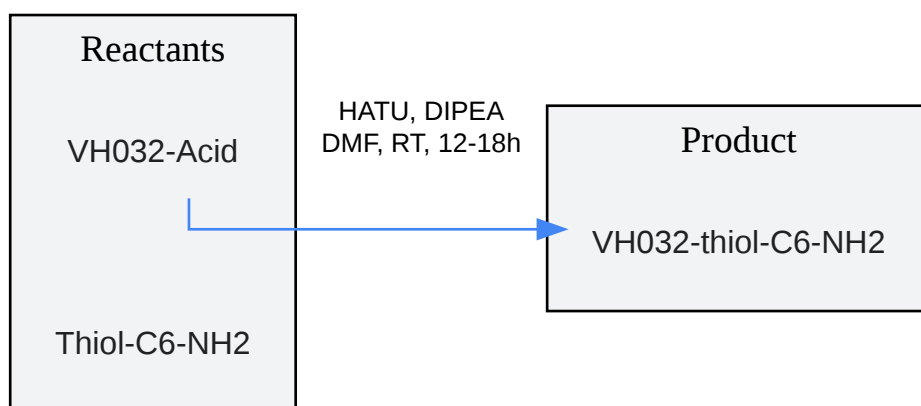

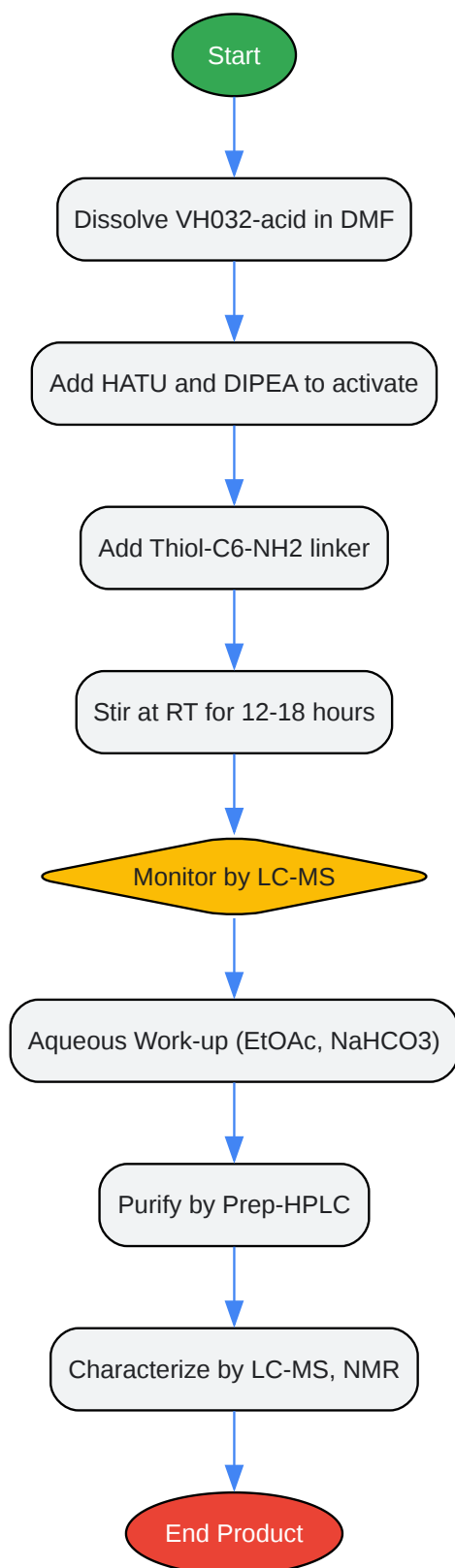

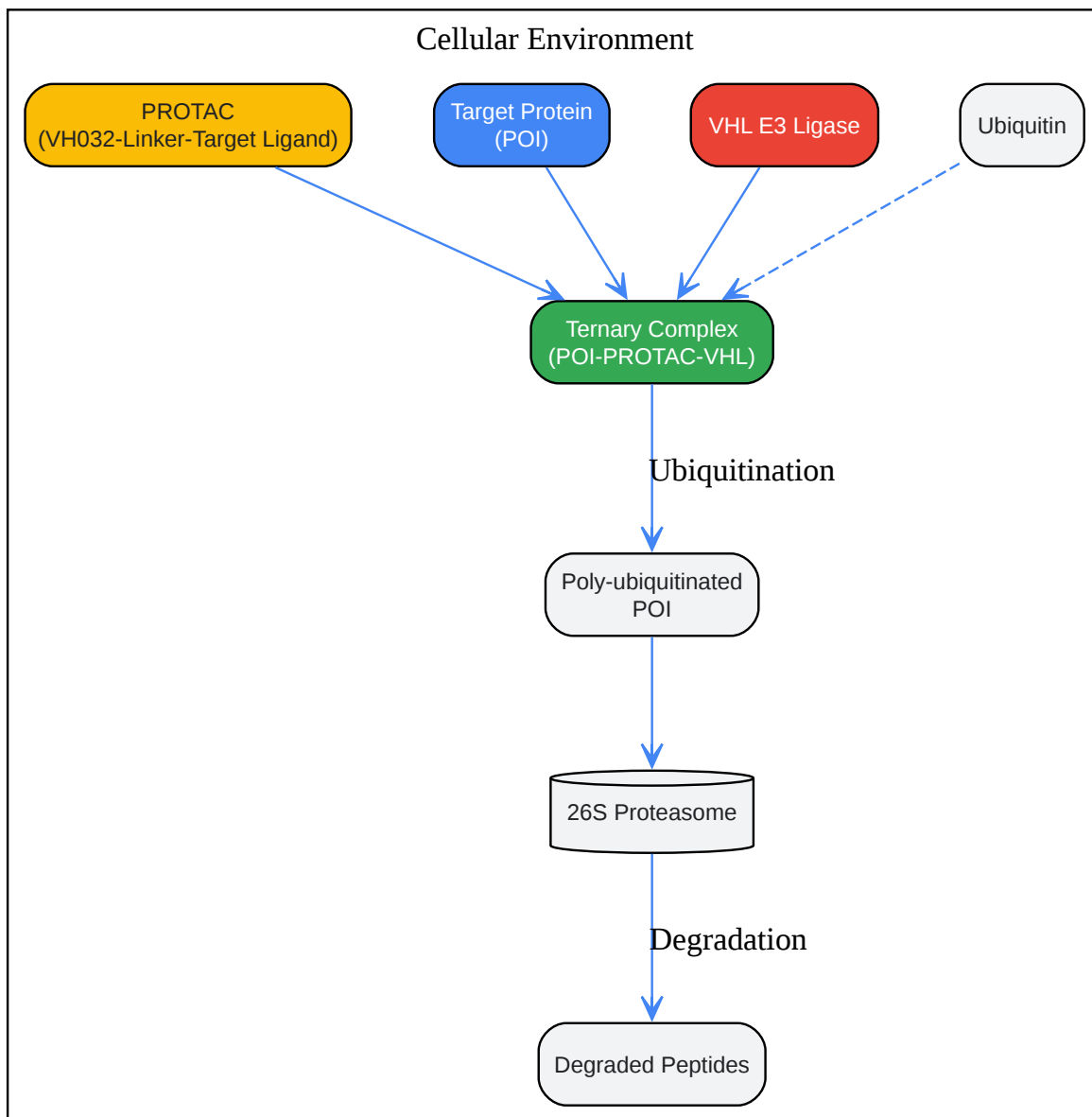

[Click to download full resolution via product page](#)

### Need Custom Synthesis?

BenchChem offers custom synthesis for rare earth carbides and specific isotopic labeling.

Email: [info@benchchem.com](mailto:info@benchchem.com) or [Request Quote Online](#).

## References

- [1. Discovery of small molecule ligands for the von Hippel-Lindau \(VHL\) E3 ligase and their use as inhibitors and PROTAC degraders - PMC \[pmc.ncbi.nlm.nih.gov\]](#)
- [2. Workflow for E3 Ligase Ligand Validation for PROTAC Development - PMC \[pmc.ncbi.nlm.nih.gov\]](#)
- [3. Synthesis and Biological Activity of a VHL-Based PROTAC Specific for p38 \$\alpha\$  - PMC \[pmc.ncbi.nlm.nih.gov\]](#)
- [4. Feasible Column Chromatography-Free, Multi-Gram Scale Synthetic Process of VH032 Amine, Which Could Enable Rapid PROTAC Library Construction - PMC \[pmc.ncbi.nlm.nih.gov\]](#)
- To cite this document: BenchChem. [Application Notes: Synthesis of VH032-Thiol-C6-NH2 Conjugate for PROTAC Development]. BenchChem, [2026]. [Online PDF]. Available at: [<https://www.benchchem.com/product/b15577031/docs#application-notes-synthesis-of-vh032-thiol-c6-nh2-conjugate-for-protac-development>]

---

### Disclaimer & Data Validity:

The information provided in this document is for Research Use Only (RUO) and is strictly not intended for diagnostic or therapeutic procedures. While BenchChem strives to provide accurate protocols, we make no warranties, express or implied, regarding the fitness of this product for every specific experimental setup.

**Technical Support:** The protocols provided are for reference purposes. Unsure if this reagent suits your experiment?

**Need Industrial/Bulk Grade?** [Request Custom Synthesis Quote](#)

## BenchChem

Our mission is to be the trusted global source of essential and advanced chemicals, empowering scientists and researchers to drive progress in science and industry.

### Contact

Address: 3281 E Guasti Rd  
Ontario, CA 91761, United States  
Phone: (601) 213-4426  
Email: [info@benchchem.com](mailto:info@benchchem.com)

Contact our Ph.D. Support Team for a compatibility check