

The Cellular Landscape of ARL16: A Technical Guide

Author: BenchChem Technical Support Team. **Date:** April 2026

Compound of Interest

Compound Name: *ARL16 Human Pre-designed
siRNA Set A*

Cat. No.: *B15575849*

[Get Quote](#)

For Researchers, Scientists, and Drug Development Professionals

This in-depth technical guide explores the cellular localization of the ADP-ribosylation factor-like 16 (ARL16) protein. A comprehensive understanding of a protein's subcellular distribution is fundamental to elucidating its function and its potential as a therapeutic target. This document summarizes the current knowledge of ARL16 localization, provides detailed experimental methodologies, and visualizes associated signaling pathways.

Subcellular Localization of ARL16

ARL16, a member of the ARF family of small GTPases, exhibits a complex and dynamic subcellular distribution, suggesting its involvement in multiple cellular processes.^{[1][2]} Studies have identified ARL16 in several distinct cellular compartments, including the cytosol, mitochondria, and perhaps most significantly, the primary cilium and its associated structures.^{[1][3][4][5]} The localization can also be isoform-dependent.^{[1][3]}

Quantitative Distribution of ARL16

While much of the localization data is qualitative, the following table summarizes the observed distribution of ARL16 across different cell types and experimental conditions.

Cellular Compartment	Cell Type(s)	Method(s)	Description of Localization	Reference(s)
Primary Cilium	hTERT-RPE1	Immunofluorescence	Punctate staining along the ciliary axoneme.	[1][3][4]
Human Retinal Photoreceptors	Immunofluorescence	Localized to the ciliary region and the inner segment. Specifically found in the periciliary region at the base of the connecting cilium.	[1][2][4][5]	
Mitochondria	hTERT-RPE1	Immunofluorescence (co-localization with HSP60)	Co-localizes with the mitochondrial protein HSP60.	[1][3][4][5]
MEFs (exogenous expression)	Immunofluorescence	The 197-residue human isoform strongly co-localizes with HSP60 at mitochondria.	[1][3]	
Cytosol	HEK293, HeLa	Not specified	Previously reported to be cytosolic.	[1][2][3][6]
MEFs (exogenous expression)	Immunofluorescence	The 173-residue human and mouse isoforms show diffuse cytosolic staining.	[1][2][3]	

hTERT-RPE1	Immunofluorescence	Diffuse staining across the cell.	[1][3][4][5]
Basal Body	Human Retinal Photoreceptors	Immunofluorescence (co-localization with Centrin 3)	Found at the basal body. [1][2][4][5]
Golgi Apparatus	Indirectly implicated	Genetic knockout studies	Knockout of Arl16 leads to the accumulation of the ciliary proteins IFT140 and INPP5E at the Golgi, suggesting a role in Golgi-to-cilia trafficking. [1][3][7]

ARL16-Associated Signaling Pathways

ARL16 is implicated in at least two distinct signaling pathways: the regulation of protein trafficking to the primary cilium and the innate immune response to viral pathogens.

Golgi-to-Cilium Trafficking Pathway

ARL16 plays a crucial role in the transport of specific proteins, namely IFT140 and INPP5E, from the Golgi apparatus to the primary cilium. Its absence leads to the aberrant accumulation of these proteins at the Golgi, which in turn disrupts ciliogenesis and ciliary function.[1][3][7]

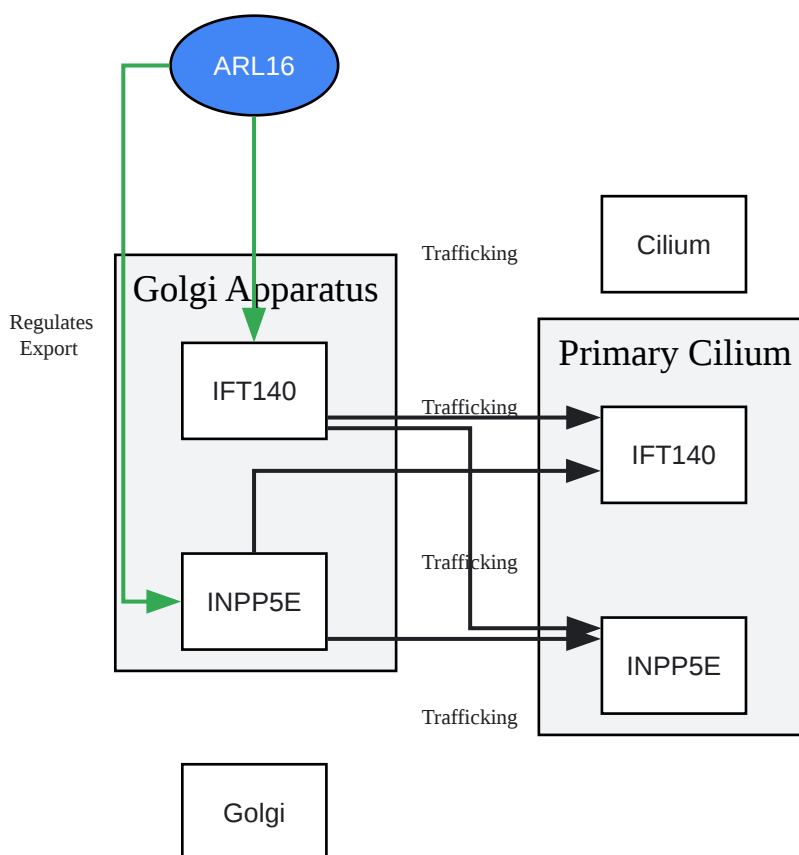

[Click to download full resolution via product page](#)

Caption: ARL16-mediated regulation of protein export from the Golgi to the cilium.

RIG-I Antiviral Signaling Pathway

ARL16 has been identified as a negative regulator of the RIG-I-mediated antiviral response.[8] It interacts with the C-terminal domain (CTD) of RIG-I in a GTP-dependent manner, which is thought to inhibit RIG-I's ability to bind to viral RNA and initiate downstream signaling, thereby preventing an excessive immune response.[8]

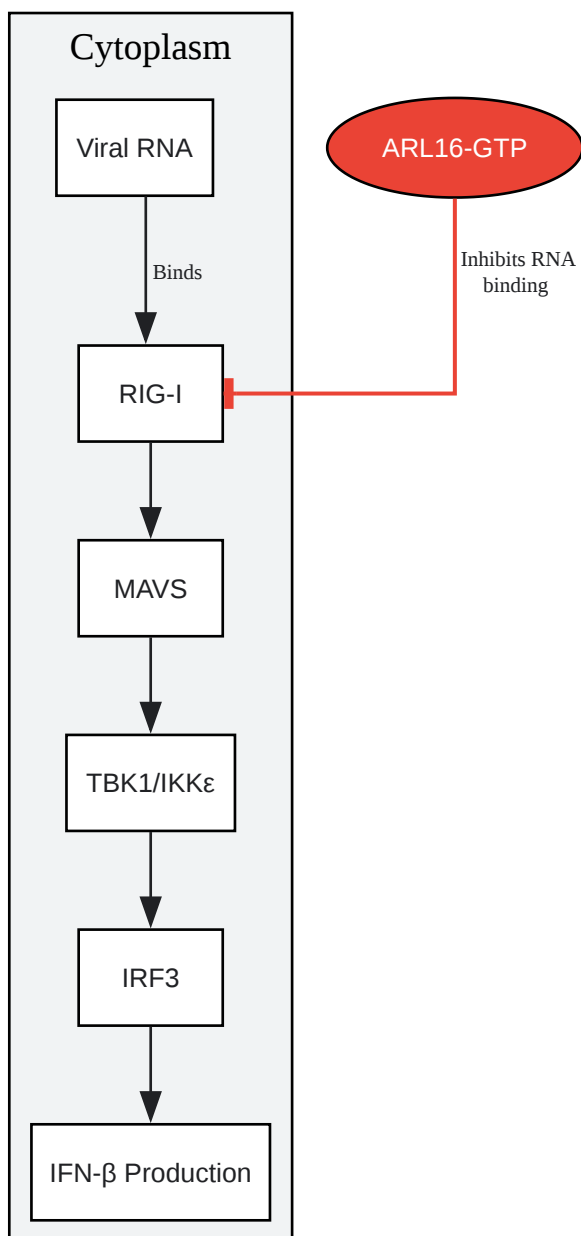

[Click to download full resolution via product page](#)

Caption: Inhibitory role of ARL16 in the RIG-I antiviral signaling pathway.

Experimental Protocols

The following are detailed methodologies for key experiments used to determine the cellular localization of ARL16.

Immunofluorescence Staining for ARL16

This protocol is adapted from methodologies used to visualize endogenous and exogenously expressed ARL16.^{[1][9]}

3.1.1. Cell Culture and Fixation

- Culture hTERT-RPE1 or other suitable cells on glass coverslips.
- For ciliation studies, serum-starve the cells for 24-48 hours.
- Wash the cells twice with phosphate-buffered saline (PBS).
- Fix the cells using one of the following methods:
 - Paraformaldehyde (PFA) Fixation: Incubate with 4% PFA in PBS for 15 minutes at room temperature.
 - Methanol Fixation: Incubate with ice-cold methanol for 10 minutes at -20°C.
- Wash the cells three times with PBS for 5 minutes each.

3.1.2. Permeabilization and Blocking

- Permeabilize the cells with 0.1% Triton X-100 in PBS for 10 minutes.
- Wash three times with PBS.
- Block with 5% normal goat serum (or other appropriate serum) and 0.05% Triton X-100 in PBS for 1 hour at room temperature.

3.1.3. Antibody Incubation

- Dilute the primary antibody (e.g., anti-ARL16) in the blocking buffer.
- Incubate the cells with the primary antibody overnight at 4°C.
- For co-localization studies, incubate with a second primary antibody targeting a marker for a specific organelle (e.g., anti-HSP60 for mitochondria, anti-acetylated tubulin for cilia).

- Wash the cells three times with PBS containing 0.05% Triton X-100 for 5 minutes each.
- Dilute the fluorescently-labeled secondary antibody in the blocking buffer.
- Incubate the cells with the secondary antibody for 1 hour at room temperature in the dark.
- Wash three times with PBS containing 0.05% Triton X-100 for 5 minutes each.

3.1.4. Mounting and Imaging

- Mount the coverslips on glass slides using a mounting medium containing DAPI for nuclear counterstaining.
- Seal the coverslips with nail polish.
- Image the slides using a confocal or epifluorescence microscope.

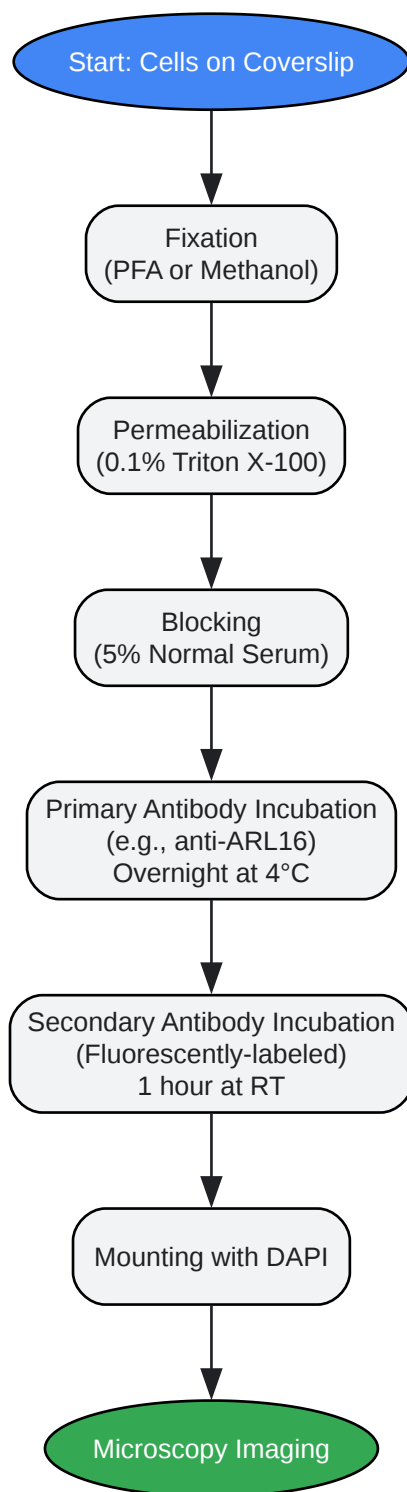

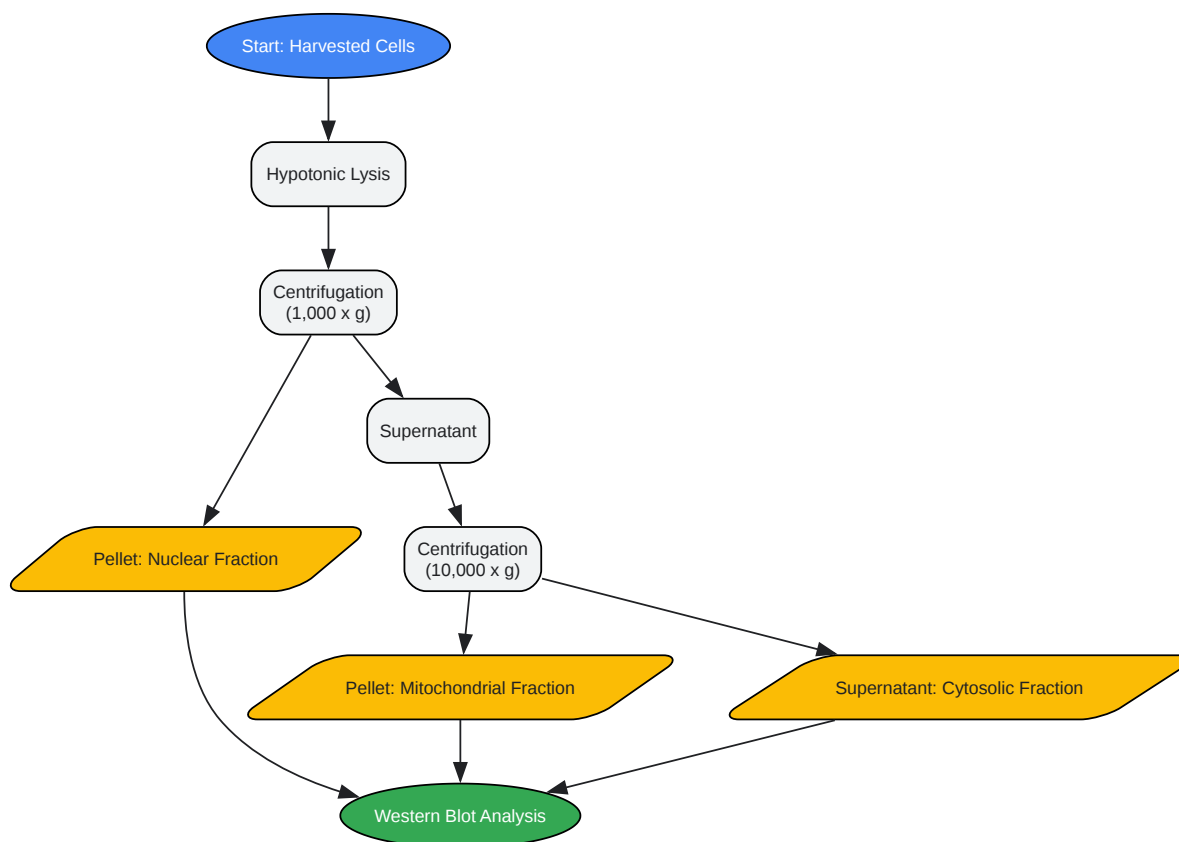

[Click to download full resolution via product page](#)

Need Custom Synthesis?

BenchChem offers custom synthesis for rare earth carbides and specific isotopic labeling.

Email: info@benchchem.com or [Request Quote Online](#).

References

- [1. biorxiv.org \[biorxiv.org\]](#)
- [2. Phylogenetic profiling and cellular analyses of ARL16 reveal roles in traffic of IFT140 and INPP5E - PMC \[pmc.ncbi.nlm.nih.gov\]](#)
- [3. biorxiv.org \[biorxiv.org\]](#)
- [4. researchgate.net \[researchgate.net\]](#)
- [5. researchgate.net \[researchgate.net\]](#)
- [6. molbiolcell.org \[molbiolcell.org\]](#)
- [7. molbiolcell.org \[molbiolcell.org\]](#)
- [8. ARF-like Protein 16 \(ARL16\) Inhibits RIG-I by Binding with Its C-terminal Domain in a GTP-dependent Manner - PMC \[pmc.ncbi.nlm.nih.gov\]](#)
- [9. usbio.net \[usbio.net\]](#)
- To cite this document: BenchChem. [The Cellular Landscape of ARL16: A Technical Guide]. BenchChem, [2026]. [Online PDF]. Available at: [\[https://www.benchchem.com/product/b15575849/docs#the-cellular-landscape-of-arl16-a-technical-guide\]](https://www.benchchem.com/product/b15575849/docs#the-cellular-landscape-of-arl16-a-technical-guide)

Disclaimer & Data Validity:

The information provided in this document is for Research Use Only (RUO) and is strictly not intended for diagnostic or therapeutic procedures. While BenchChem strives to provide accurate protocols, we make no warranties, express or implied, regarding the fitness of this product for every specific experimental setup.

Technical Support: The protocols provided are for reference purposes. Unsure if this reagent suits your experiment?

Need Industrial/Bulk Grade? [Request Custom Synthesis Quote](#)

BenchChem

Our mission is to be the trusted global source of essential and advanced chemicals, empowering scientists and researchers to drive progress in science and industry.

Contact

Address: 3281 E Guasti Rd

Ontario, CA 91761, United States

Phone: (601) 213-4426

Email: info@benchchem.com

[Contact our Ph.D. Support Team for a compatibility check](#)