

Technical Support Center: Optimizing Boc Deprotection of endo-BCN-PEG4-Boc

Author: BenchChem Technical Support Team. **Date:** April 2026

Compound of Interest

Compound Name: *endo-BCN-PEG4-Boc*

Cat. No.: *B15575395*

[Get Quote](#)

This guide provides troubleshooting advice and frequently asked questions to assist researchers, scientists, and drug development professionals in optimizing the Boc deprotection of **endo-BCN-PEG4-Boc**.

Troubleshooting Guide

Issue 1: Incomplete or Slow Deprotection

Symptoms:

- Presence of starting material (**endo-BCN-PEG4-Boc**) in the reaction mixture after the expected reaction time, as observed by TLC, LC-MS, or NMR.
- A complex mixture of products, including partially deprotected species.

Potential Causes & Solutions:

Potential Cause	Suggested Solution
Insufficient Acid Strength or Concentration	<p>The tert-butoxycarbonyl (Boc) group is cleaved by acidolysis. If the acid concentration is too low, the reaction may not go to completion.</p> <p>Increase the concentration of the acid (e.g., from 20% TFA in DCM to 50% TFA in DCM). Alternatively, consider a stronger acid system like 4M HCl in 1,4-dioxane.[1]</p>
Inadequate Reaction Time or Temperature	<p>Deprotection is a kinetic process. For some substrates, room temperature may not be sufficient for complete deprotection within a typical timeframe.[1] Extend the reaction time and continue to monitor the progress. Gentle heating might be considered if the molecule is stable at elevated temperatures, but this should be approached with caution to avoid side reactions.</p>
Steric Hindrance	<p>The bulky nature of the PEG chain can sterically hinder the approach of the acid to the Boc-protected amine, slowing down the reaction.[1]</p> <p>Using a higher concentration of acid or a stronger acid system can help overcome this.</p>
Solvent Issues	<p>Proper solvation of both the PEGylated compound and the acid is crucial for an efficient reaction. Dichloromethane (DCM) is a commonly used solvent for TFA-mediated deprotection.[1] Ensure your starting material is fully dissolved in the chosen solvent.</p>

Issue 2: Observation of Side Products

Symptoms:

- Unexpected peaks in HPLC or LC-MS analysis of the crude product.

- Mass spectral data indicating modifications to the BCN ring or other parts of the molecule.

Potential Causes & Solutions:

Potential Cause	Suggested Solution
Alkylation by Tert-butyl Cation	The cleavage of the Boc group generates a reactive tert-butyl cation, which can alkylate nucleophilic sites on the molecule.[2][3] To prevent this, add a scavenger to the reaction mixture. Common scavengers include triisopropylsilane (TIS) or triethylsilane (TES), typically at a concentration of 2.5-5% (v/v).[1][2]
Acid-Labile Functional Groups	If your molecule contains other acid-sensitive groups, they may be cleaved or modified under the deprotection conditions.[1] Consider using milder deprotection conditions, such as a lower concentration of acid or a shorter reaction time. For highly sensitive substrates, alternative deprotection methods might be necessary.[4][5][6]
BCN Ring Instability	While the BCN group is generally stable, strong acidic conditions could potentially lead to side reactions. Monitor the reaction closely for any degradation of the BCN moiety. If degradation is observed, milder conditions are recommended.

Frequently Asked Questions (FAQs)

Q1: What are the standard starting conditions for Boc deprotection of a PEGylated amine like **endo-BCN-PEG4-Boc**?

A common starting point is to dissolve the Boc-protected compound in dichloromethane (DCM) at a concentration of 0.1-0.2 M and cool it to 0°C in an ice bath.[1] Then, add trifluoroacetic acid (TFA) to a final concentration of 20-50% (v/v).[1]

Q2: How should I monitor the progress of the deprotection reaction?

The reaction progress can be monitored by Thin Layer Chromatography (TLC) or Liquid Chromatography-Mass Spectrometry (LC-MS).[1][7] By comparing the spot or peak of the starting material with the newly formed product spot/peak, you can determine when the reaction is complete.

Q3: What is the appropriate work-up procedure after the deprotection is complete?

Upon completion, the reaction mixture is typically concentrated under reduced pressure to remove the solvent and excess TFA.[1] To remove residual TFA, co-evaporation with a solvent like toluene (3 times) is often effective.[1] The resulting TFA salt of the deprotected amine can sometimes be used directly in the next step.[8]

Q4: How can I neutralize the TFA salt to obtain the free amine?

If the free amine is required, the residue can be dissolved in a suitable organic solvent and washed with a basic aqueous solution, such as saturated sodium bicarbonate.[1][7] The organic layer is then dried over an anhydrous salt (e.g., sodium sulfate), filtered, and concentrated to yield the free amine.[7]

Q5: My deprotected product is an oil and difficult to handle. What can I do?

TFA salts of amines are often oily.[9] One common technique is to precipitate the deprotected product from the reaction mixture by adding a non-polar solvent like diethyl ether.[1] Alternatively, using a different acid for deprotection, such as 4M HCl in 1,4-dioxane, often yields a solid hydrochloride salt which can be easier to isolate.[9]

Experimental Protocols

General Protocol for Boc Deprotection using TFA

This protocol is a general guideline and may require optimization for your specific substrate.

Materials:

- **endo-BCN-PEG4-Boc**

- Dichloromethane (DCM), anhydrous
- Trifluoroacetic acid (TFA)
- Triisopropylsilane (TIS) (optional, as a scavenger)
- Toluene
- Saturated sodium bicarbonate solution
- Anhydrous sodium sulfate
- Round-bottom flask
- Magnetic stirrer and stir bar
- Ice bath

Procedure:

- Dissolve the **endo-BCN-PEG4-Boc** in anhydrous DCM to a concentration of 0.1-0.2 M in a round-bottom flask.
- Cool the solution to 0°C using an ice bath.
- Slowly add TFA to the desired final concentration (e.g., 20-50% v/v).
- If using a scavenger, add TIS to a final concentration of 2.5-5% (v/v).^[1]
- Stir the reaction at 0°C for 30 minutes, then allow it to warm to room temperature.^[1]
- Monitor the reaction progress by TLC or LC-MS until the starting material is consumed (typically 1-2 hours).^[1]
- Upon completion, concentrate the reaction mixture under reduced pressure.
- Add toluene and concentrate again under reduced pressure. Repeat this step two more times to remove residual TFA.^[1]

- The resulting TFA salt can be used directly or neutralized as described in the FAQs.

Data Presentation

General Reaction Conditions for Boc Deprotection

Parameter	TFA in DCM	HCl in 1,4-Dioxane
Acid Concentration	20-50% (v/v)[1]	4M[1][9]
Temperature	0°C to Room Temperature[1]	Room Temperature[9]
Reaction Time	30 minutes - 2 hours[1][7]	1 - 4 hours[7]
Scavengers	TIS, TES (2.5-5% v/v)[1][2]	Not typically required
Typical Product Form	TFA salt (often oily)[9]	HCl salt (often solid)[9]

Visualizations

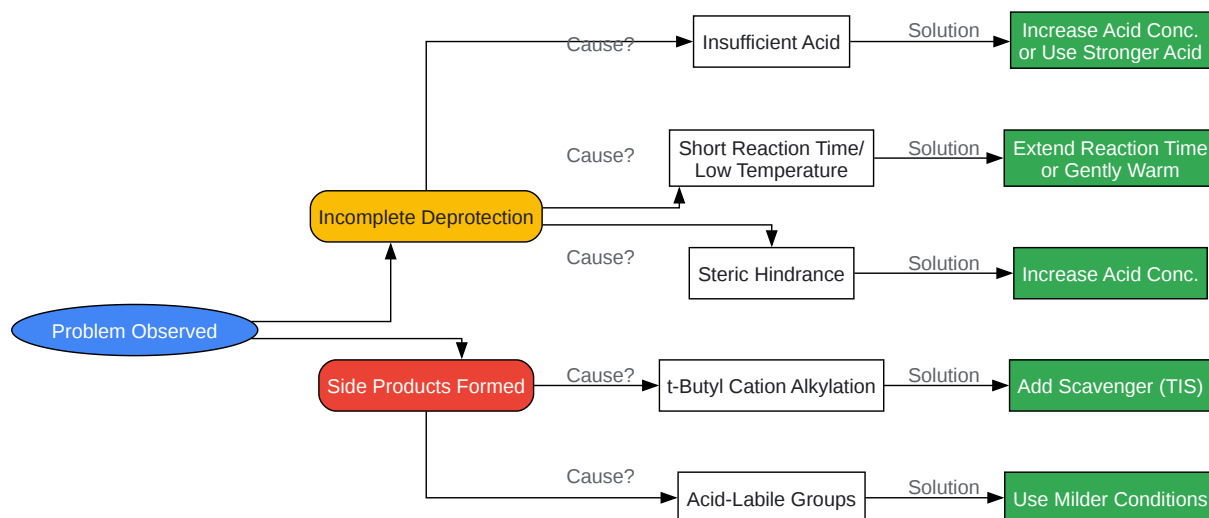

[Click to download full resolution via product page](#)

Caption: Troubleshooting workflow for Boc deprotection.

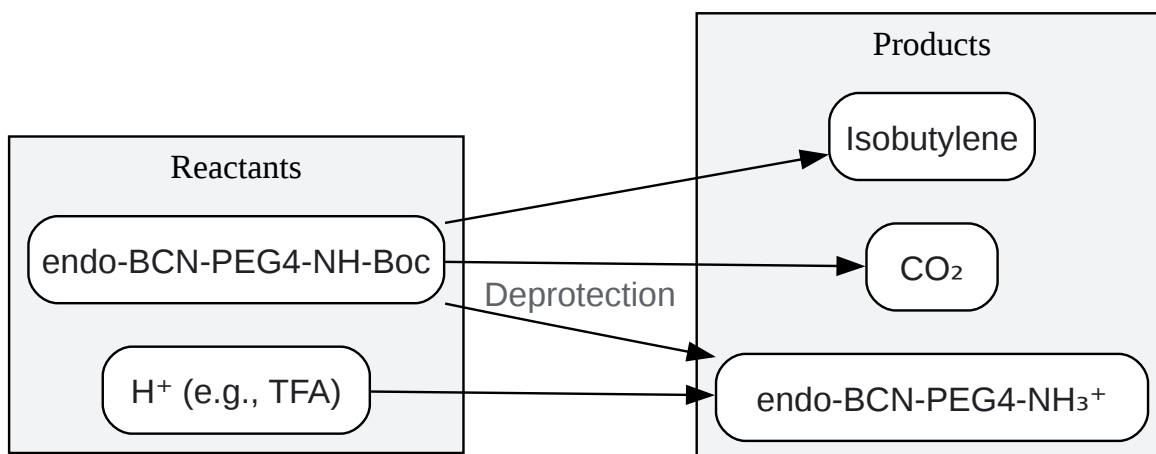

[Click to download full resolution via product page](#)

Caption: General reaction pathway for acid-catalyzed Boc deprotection.

Need Custom Synthesis?

BenchChem offers custom synthesis for rare earth carbides and specific isotopic labeling.

Email: info@benchchem.com or [Request Quote Online](#).

References

- [1. benchchem.com \[benchchem.com\]](https://www.benchchem.com)
- [2. benchchem.com \[benchchem.com\]](https://www.benchchem.com)
- [3. BOC Deprotection - Wordpress \[reagents.acsgcipr.org\]](https://reagents.acsgcipr.org)
- [4. Mild deprotection of the N-tert-butyloxycarbonyl \(N-Boc\) group using oxalyl chloride - PMC \[pmc.ncbi.nlm.nih.gov\]](https://pmc.ncbi.nlm.nih.gov)
- [5. mdpi.com \[mdpi.com\]](https://mdpi.com)
- [6. pdfs.semanticscholar.org \[pdfs.semanticscholar.org\]](https://pdfs.semanticscholar.org)

- [7. benchchem.com \[benchchem.com\]](https://www.benchchem.com)
- [8. rsc.org \[rsc.org\]](https://www.rsc.org)
- [9. reddit.com \[reddit.com\]](https://www.reddit.com)
- To cite this document: BenchChem. [Technical Support Center: Optimizing Boc Deprotection of endo-BCN-PEG4-Boc]. BenchChem, [2026]. [Online PDF]. Available at: [<https://www.benchchem.com/product/b15575395/docs#technical-support-center-optimizing-boc-deprotection-of-endo-bcn-peg4-boc>]

Disclaimer & Data Validity:

The information provided in this document is for Research Use Only (RUO) and is strictly not intended for diagnostic or therapeutic procedures. While BenchChem strives to provide accurate protocols, we make no warranties, express or implied, regarding the fitness of this product for every specific experimental setup.

Technical Support: The protocols provided are for reference purposes. Unsure if this reagent suits your experiment?

Need Industrial/Bulk Grade? [Request Custom Synthesis Quote](#)

BenchChem

Our mission is to be the trusted global source of essential and advanced chemicals, empowering scientists and researchers to drive progress in science and industry.

Contact

Address: 3281 E Guasti Rd
Ontario, CA 91761, United States
Phone: (601) 213-4426
Email: info@benchchem.com

[Contact our Ph.D. Support Team for a compatibility check](#)

