

# Investigating the Cellular Targets of GNF362: A Technical Guide

**Author:** BenchChem Technical Support Team. **Date:** April 2026

## Compound of Interest

Compound Name: GNF362  
Cat. No.: B15575103

[Get Quote](#)

For Researchers, Scientists, and Drug Development Professionals

## Abstract

**GNF362** is a potent, selective, and orally bioavailable small molecule inhibitor of inositol trisphosphate 3-kinase B (ITPKB). By targeting a key negative regulator of intracellular calcium signaling, **GNF362** represents a novel therapeutic strategy for T-cell mediated autoimmune diseases and potentially other indications. This technical guide provides an in-depth overview of the cellular targets of **GNF362**, its mechanism of action, and detailed protocols for key experiments used to characterize its activity.

## Introduction

T-lymphocyte activation is a critical event in the adaptive immune response, and its dysregulation can lead to autoimmune and inflammatory disorders. A key second messenger in T-cell signaling is inositol 1,4,5-trisphosphate (IP3), which mobilizes intracellular calcium (Ca<sup>2+</sup>) stores. Inositol trisphosphate 3-kinase B (ITPKB) acts as a negative regulator in this pathway by phosphorylating IP3 to inositol 1,3,4,5-tetrakisphosphate (IP4), thereby terminating the IP3-mediated Ca<sup>2+</sup> signal.[1]

**GNF362** was identified through high-throughput screening as a potent inhibitor of ITPKB.[2] Its mechanism of action involves blocking this negative regulatory step, leading to sustained and augmented intracellular Ca<sup>2+</sup> levels in activated lymphocytes. This enhanced Ca<sup>2+</sup> signal drives pathogenic T-cells towards apoptosis, a process known as activation-induced cell death. [1][2] This targeted approach offers the potential for selective depletion of alloreactive T-cells while sparing other immune functions.[1]

## Cellular Targets and Potency

**GNF362** is a highly potent inhibitor of the inositol trisphosphate 3-kinase (ITPK) family. Its primary target is ITPKB, with slightly lower potency against ITPKA and ITPKC. The selectivity of **GNF362** is a key attribute, as it shows minimal activity against a broad panel of other protein and lipid kinases.[2]

**Table 1: In Vitro Potency of GNF362**

Target	IC50 (nM)	Cellular Effect	EC50 (nM)
ITPKB	9	Induction of Calcium Influx (mouse splenocytes)	12
ITPKA	20		
ITPKC	19		

Data compiled from publicly available sources.[2][3]

## Signaling Pathway of GNF362 Action

The primary mechanism of **GNF362** is the modulation of the IP3 signaling pathway, which is crucial for T-cell activation.

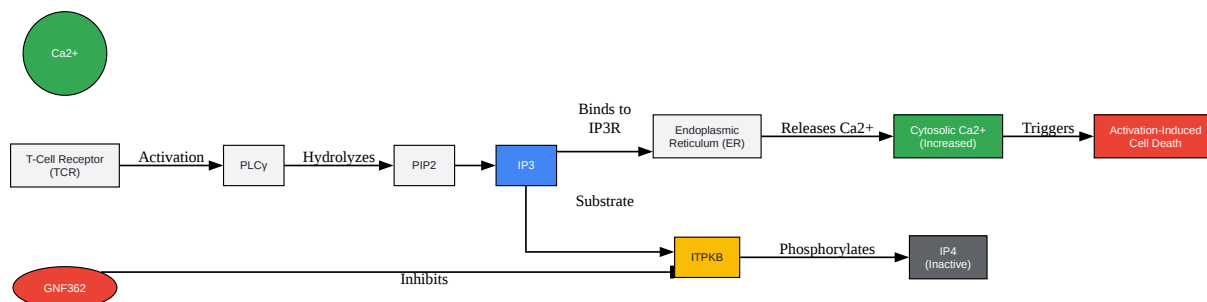

[Click to download full resolution via product page](#)

Caption: **GNF362** inhibits ITPKB, leading to increased IP<sub>3</sub>, enhanced Ca<sup>2+</sup> release, and T-cell apoptosis.

## Experimental Protocols

This section provides detailed methodologies for key experiments used to characterize the cellular effects of **GNF362**.

### In Vitro Kinase Inhibition Assay (Kinase-Glo™)

This assay quantifies the activity of ITPK enzymes by measuring the amount of ATP remaining after the kinase reaction.

Workflow:

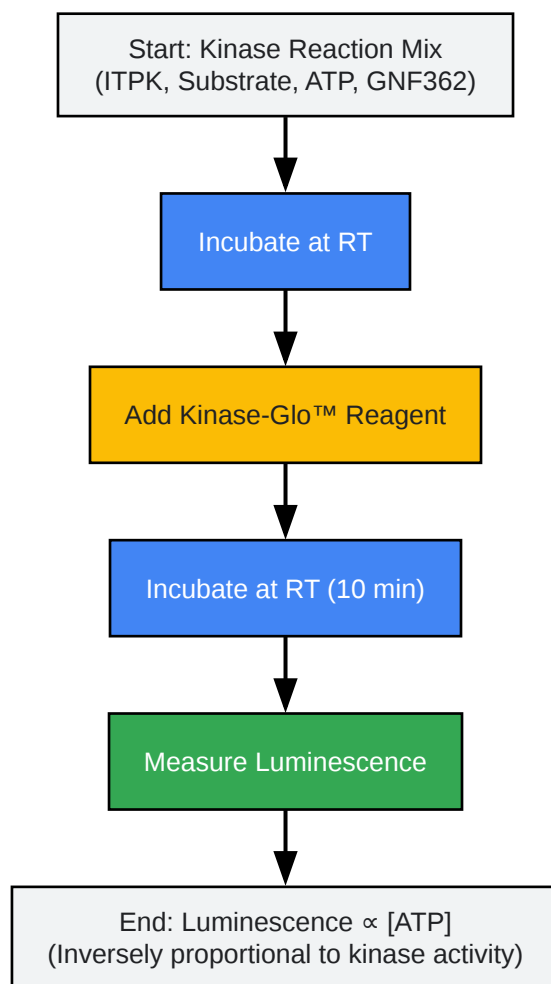

[Click to download full resolution via product page](#)

Caption: Workflow for the Kinase-Glo™ assay to measure **GNF362**'s inhibitory activity.

#### Methodology:

- Prepare a kinase reaction buffer (e.g., 40 mM Tris-HCl pH 7.5, 20 mM MgCl<sub>2</sub>, 0.1 mg/mL BSA).
- In a 96-well or 384-well white plate, add the ITPK enzyme (ITPKA, ITPKB, or ITPKC), its substrate (IP3), and varying concentrations of **GNF362**.
- Initiate the reaction by adding ATP (e.g., 10 μM).
- Incubate the plate at room temperature for a predetermined time (e.g., 60 minutes).

- Add a volume of Kinase-Glo™ Reagent equal to the volume of the kinase reaction in each well.[4][5]
- Mix the contents on a plate shaker for 2 minutes to induce cell lysis and inhibit kinase activity.
- Incubate at room temperature for 10 minutes to stabilize the luminescent signal.[6]
- Measure luminescence using a plate-reading luminometer.
- Calculate IC50 values by plotting the percentage of kinase inhibition against the log concentration of **GNF362**.

## Cellular Calcium Flux Assay

This assay measures changes in intracellular calcium concentration in response to cell stimulation in the presence of **GNF362**.

Methodology:

- Isolate splenocytes or purified T-cells from a suitable source (e.g., mouse spleen).
- Resuspend cells to a concentration of  $1 \times 10^6$  cells/mL.
- Load the cells with a calcium-sensitive dye, such as Fluo-4 AM (1-2  $\mu$ M for lymphocytes), by incubating at 37°C for 30-45 minutes.[3][7]
- Wash the cells twice with a calcium-free buffer (e.g., PBS) to remove excess dye.[3]
- Pre-incubate the cells with varying concentrations of **GNF362**.
- Establish a baseline fluorescence reading using a flow cytometer or a fluorescence plate reader (e.g., FLIPR).[8]
- Stimulate the cells with an appropriate agonist (e.g., anti-IgM for B-cells or anti-CD3/CD28 for T-cells) to induce IP3 production and initial calcium release from intracellular stores.
- Add extracellular calcium to the buffer to measure store-operated calcium entry (SOCE).

- Record the fluorescence intensity over time. The peak fluorescence is proportional to the intracellular calcium concentration.
- Calculate EC50 values based on the dose-dependent increase in peak calcium response.

## T-Cell Proliferation and Apoptosis Assay

This experiment assesses the effect of **GNF362** on T-cell proliferation and its ability to induce activation-induced cell death.

Logical Flow:

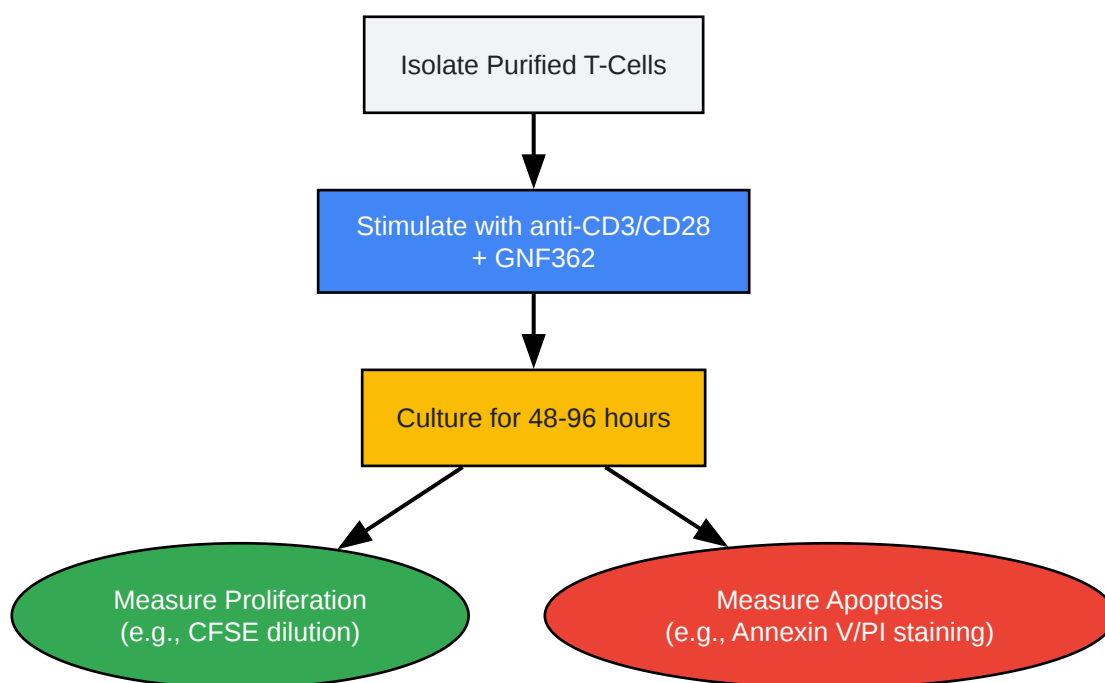

[Click to download full resolution via product page](#)

### Need Custom Synthesis?

BenchChem offers custom synthesis for rare earth carbides and specific isotopic labeling.

Email: [info@benchchem.com](mailto:info@benchchem.com) or [Request Quote Online](#).

## References

- [1. antibody-creativebiolabs.com \[antibody-creativebiolabs.com\]](https://antibody-creativebiolabs.com)
- [2. bio-rad-antibodies.com \[bio-rad-antibodies.com\]](https://bio-rad-antibodies.com)
- [3. Fluo-3 and Fluo-4 Protocols \[icms.qmul.ac.uk\]](https://icms.qmul.ac.uk)
- [4. Kinase-Glo® Luminescent Kinase Assay Platform Protocol \[promega.com\]](https://promega.com)
- [5. ebiotrade.com \[ebiotrade.com\]](https://ebiotrade.com)
- [6. promega.com \[promega.com\]](https://promega.com)
- [7. Calcium Imaging in T Lymphocytes: a Protocol for Use with Genetically Encoded or Chemical Ca<sup>2+</sup> Indicators - PMC \[pmc.ncbi.nlm.nih.gov\]](https://pubmed.ncbi.nlm.nih.gov/16111111/)
- [8. moleculardevices.com \[moleculardevices.com\]](https://moleculardevices.com)
- To cite this document: BenchChem. [Investigating the Cellular Targets of GNF362: A Technical Guide]. BenchChem, [2026]. [Online PDF]. Available at: [\[https://www.benchchem.com/product/b15575103/docs#investigating-the-cellular-targets-of-gnf362-a-technical-guide\]](https://www.benchchem.com/product/b15575103/docs#investigating-the-cellular-targets-of-gnf362-a-technical-guide)

---

### Disclaimer & Data Validity:

The information provided in this document is for Research Use Only (RUO) and is strictly not intended for diagnostic or therapeutic procedures. While BenchChem strives to provide accurate protocols, we make no warranties, express or implied, regarding the fitness of this product for every specific experimental setup.

**Technical Support:** The protocols provided are for reference purposes. Unsure if this reagent suits your experiment?

**Need Industrial/Bulk Grade?** [Request Custom Synthesis Quote](#)

## BenchChem

Our mission is to be the trusted global source of essential and advanced chemicals, empowering scientists and researchers to drive progress in science and industry.

### Contact

Address: 3281 E Guasti Rd

Ontario, CA 91761, United States

Phone: (601) 213-4426

Email: [info@benchchem.com](mailto:info@benchchem.com)

Contact our Ph.D. Support Team for a compatibility check