

# Assessing Downstream Signaling of Cbl-b Degradation: A Comparative Guide

**Author:** BenchChem Technical Support Team. **Date:** April 2026

## Compound of Interest

Compound Name: PROTAC Cbl-b-IN-1

Cat. No.: B15575071

[Get Quote](#)

For Researchers, Scientists, and Drug Development Professionals

Casitas B-lineage lymphoma-b (Cbl-b) is a critical intracellular E3 ubiquitin ligase that functions as a negative regulator of immune cell activation, particularly in T cells and Natural Killer (NK) cells.[1][2] Its degradation or inhibition unleashes potent anti-tumor immune responses, making it a prime target for cancer immunotherapy.[3] This guide provides a comparative overview of key methods to assess the downstream signaling events following Cbl-b degradation, supported by experimental data and detailed protocols.

## Introduction to Cbl-b Signaling

Cbl-b acts as a gatekeeper, setting the threshold for T-cell activation.[2][4] In the absence of co-stimulatory signals (like from CD28), Cbl-b is active and ubiquitinates key signaling proteins, targeting them for proteasomal degradation or otherwise inhibiting their function.[1][3] This ubiquitination dampens the signaling cascade originating from the T-cell receptor (TCR), leading to a state of T-cell anergy or tolerance.[4][5]

When Cbl-b is degraded or its function is inhibited, this negative regulation is lifted. This results in enhanced and sustained activation of multiple downstream signaling pathways, including the

PI3K/Akt, MAPK/ERK, and NF-κB pathways, culminating in robust T-cell proliferation, cytokine production, and cytotoxic activity.[1][4][5]

## Core Signaling Pathways Affected by Cbl-b Degradation

The degradation of Cbl-b leads to the hyperactivation of several downstream signaling molecules. Key substrates of Cbl-b's E3 ligase activity include Phospholipase C gamma 1 (PLCγ1), the p85 subunit of Phosphoinositide 3-kinase (PI3K), Vav1, and Protein Kinase C theta (PKCθ).[6][7] Consequently, assessing the status of these molecules and their downstream effectors is paramount to understanding the impact of Cbl-b degradation.

Below is a diagram illustrating the central role of Cbl-b in regulating T-cell activation.

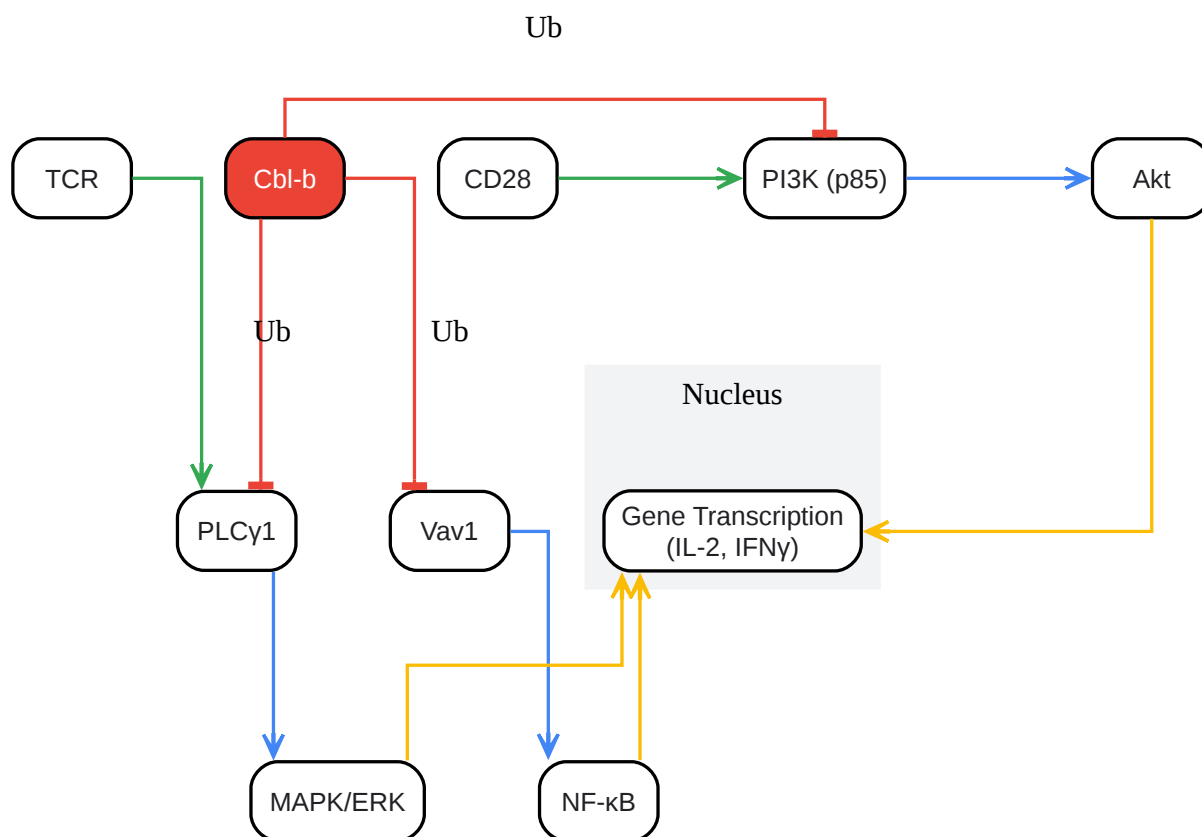

[Click to download full resolution via product page](#)

**Caption:** Cbl-b negatively regulates TCR and CD28 signaling pathways.

## Comparative Analysis of Assessment Methods

The functional consequence of Cbl-b degradation can be quantified using a variety of techniques. The choice of method depends on the specific research question, desired throughput, and available resources. Below is a comparison of common methodologies.

Method	Parameter Measured	Throughput	Quantitative	Advantages	Disadvantages
Western Blot	Protein phosphorylation (p-PLC $\gamma$ 1, p-ERK), Cbl-b protein levels	Low	Semi-quantitative	Direct measure of signaling activation, widely available	Low throughput, variability between experiments
Flow Cytometry	T-cell activation markers (CD69, CD25), proliferation (e.g., CFSE)	High	Quantitative	Single-cell data, multi-parameter analysis	Indirect measure of upstream signaling
ELISA / Luminex	Secreted cytokines (IL-2, IFN- $\gamma$ , TNF- $\alpha$ )	Medium-High	Quantitative	Functional endpoint, high sensitivity	Bulk measurement, no single-cell resolution
TR-FRET Assays	Cbl-b auto-ubiquitination or substrate ubiquitination	High	Quantitative	Homogeneous (no-wash) format, suitable for HTS	In vitro assay, may not reflect cellular complexity
Immunoprecipitation	Interaction between Cbl-b and its substrates	Low	Qualitative/Semi-quantitative	Demonstrates direct protein-protein interaction	Can be technically challenging, potential for artifacts

## Experimental Protocols

### Western Blot for Phosphorylated Downstream Targets

This protocol describes the detection of phosphorylated PLC $\gamma$ 1 (p-PLC $\gamma$ 1) and ERK1/2 (p-ERK1/2) in T-cells following Cbl-b inhibition.

Methodology:

- **Cell Treatment:** Culture primary T-cells or Jurkat T-cells. Treat cells with a Cbl-b inhibitor (e.g., NX-1607) or vehicle control for the desired time.
- **Cell Lysis:** Harvest and wash cells with ice-cold PBS. Lyse cells in RIPA buffer supplemented with protease and phosphatase inhibitors.
- **Protein Quantification:** Determine protein concentration using a BCA assay.
- **SDS-PAGE:** Load equal amounts of protein (20-30  $\mu$ g) onto a 4-12% Bis-Tris polyacrylamide gel and perform electrophoresis.
- **Protein Transfer:** Transfer proteins to a PVDF membrane.
- **Blocking:** Block the membrane with 5% non-fat milk or BSA in TBST for 1 hour at room temperature.
- **Primary Antibody Incubation:** Incubate the membrane overnight at 4°C with primary antibodies against p-PLC $\gamma$ 1, p-ERK1/2, total PLC $\gamma$ 1, total ERK1/2, and a loading control (e.g.,  $\beta$ -Actin).[8]
- **Secondary Antibody Incubation:** Wash the membrane with TBST and incubate with HRP-conjugated secondary antibodies for 1 hour at room temperature.
- **Detection:** Detect chemiluminescence using an imaging system.[8] Quantify band intensity using software like ImageJ.

## Flow Cytometry for T-Cell Activation Markers

This protocol details the assessment of CD69 expression, an early marker of T-cell activation.

Methodology:

- **Cell Stimulation:** Isolate primary human or murine T-cells.

- Treatment: Treat T-cells with a Cbl-b inhibitor or a genetic tool (e.g., siRNA) to induce Cbl-b degradation.
- Activation: Stimulate the T-cells with anti-CD3/CD28 antibodies for 18-24 hours.
- Staining: Harvest cells and wash with FACS buffer (PBS with 2% FBS). Stain with fluorescently-conjugated antibodies against CD4, CD8, and CD69 for 30 minutes on ice.
- Data Acquisition: Wash the cells and acquire data on a flow cytometer.
- Analysis: Gate on CD4+ or CD8+ T-cell populations and quantify the percentage of CD69-positive cells.

## In Vitro TR-FRET Ubiquitination Assay

This protocol provides a high-throughput method to directly measure the E3 ligase activity of Cbl-b.

Methodology:

- Reaction Setup: In a 384-well plate, combine the necessary components: E1 activating enzyme, E2 conjugating enzyme (e.g., UBE2D2), biotin-labeled ubiquitin, and GST-tagged Cbl-b.[9]
- Compound Addition: Add test compounds (potential Cbl-b inhibitors) or DMSO control.
- Initiation: Start the reaction by adding ATP. Incubate at 37°C for a specified time (e.g., 60 minutes).
- Detection: Stop the reaction and add detection reagents: a Terbium-labeled anti-GST antibody (donor) and a fluorescently-labeled streptavidin (acceptor).[9]
- Measurement: Read the Time-Resolved Fluorescence Resonance Energy Transfer (TR-FRET) signal on a compatible plate reader. A decrease in signal indicates inhibition of Cbl-b auto-ubiquitination.

## Experimental Workflow Visualization

The following diagram outlines a typical workflow for assessing the downstream effects of a novel Cbl-b inhibitor.

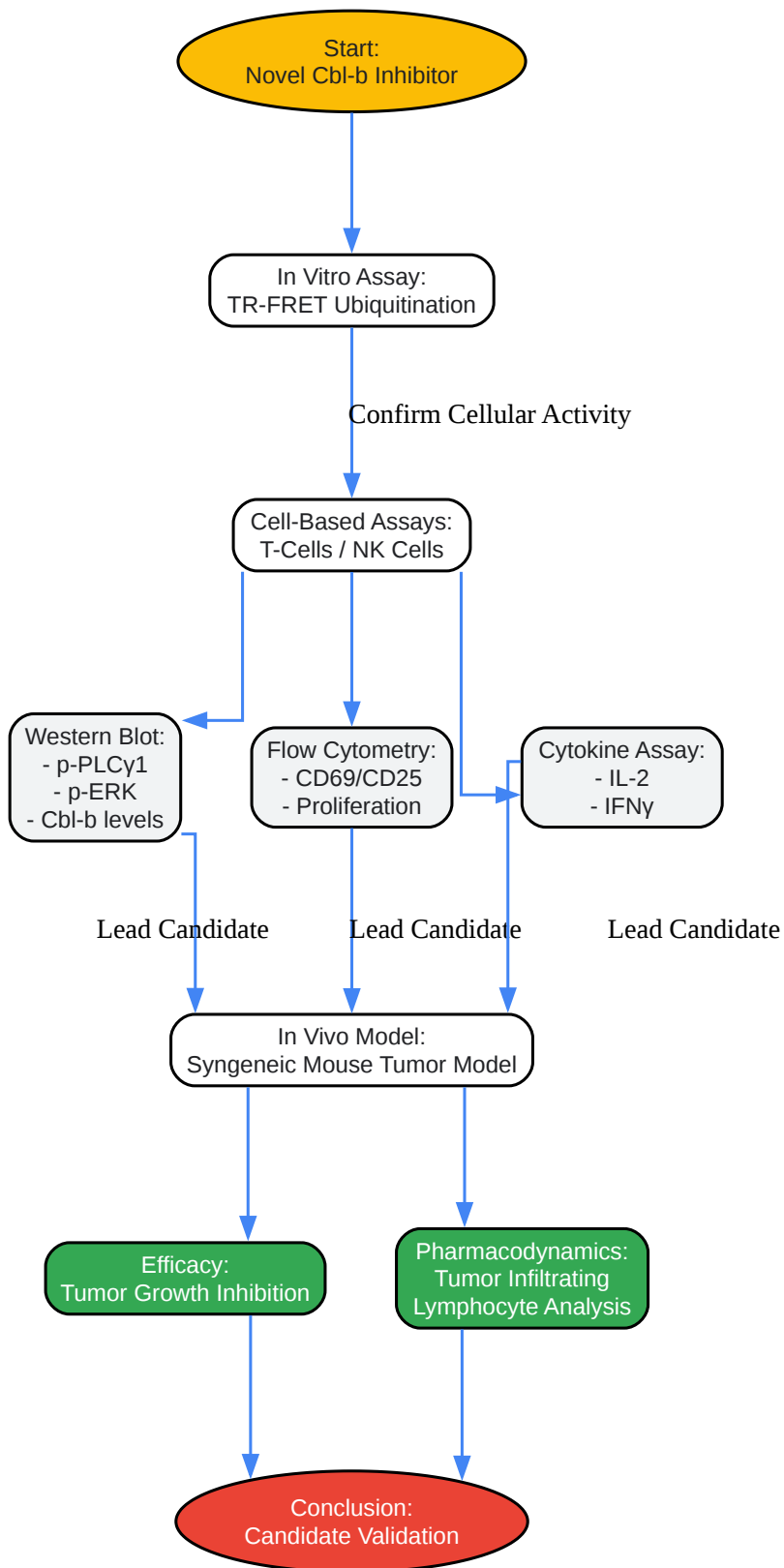

[Click to download full resolution via product page](#)

**Caption:** Workflow for preclinical assessment of a Cbl-b inhibitor.

## Conclusion

Assessing the downstream signaling of Cbl-b degradation is crucial for validating novel therapeutic strategies that target this E3 ligase. A multi-faceted approach combining direct biochemical assays, such as Western blotting for pathway activation, with functional cell-based assays, like flow cytometry for T-cell activation markers and cytokine release assays, provides a comprehensive understanding of a compound's or genetic perturbation's effect. For high-throughput screening, in vitro methods like TR-FRET offer a robust and scalable alternative.[9] By employing the appropriate combination of these methodologies, researchers can effectively characterize the immunological consequences of Cbl-b degradation and accelerate the development of next-generation immunotherapies.

### *Need Custom Synthesis?*

*BenchChem offers custom synthesis for rare earth carbides and specific isotopic labeling.*

*Email: [info@benchchem.com](mailto:info@benchchem.com) or [Request Quote Online](#).*

## References

- [1. jitc.bmj.com](http://jitc.bmj.com) [[jitc.bmj.com](http://jitc.bmj.com)]
- [2. Regulation of immune responses by E3 ubiquitin ligase Cbl-b - PMC](#) [[pmc.ncbi.nlm.nih.gov](http://pmc.ncbi.nlm.nih.gov)]
- [3. jitc.bmj.com](http://jitc.bmj.com) [[jitc.bmj.com](http://jitc.bmj.com)]
- [4. E3 ubiquitin ligase Cbl-b in innate and adaptive immunity - PMC](#) [[pmc.ncbi.nlm.nih.gov](http://pmc.ncbi.nlm.nih.gov)]
- [5. Cbl-b: Roles in T Cell Tolerance, Proallergic T Cell Development, and Cancer Immunity - PMC](#) [[pmc.ncbi.nlm.nih.gov](http://pmc.ncbi.nlm.nih.gov)]
- [6. Mechanisms of Cbl-Mediated Ubiquitination of Proteins in T and Natural Killer Cells and Effects on Immune Cell Functions - PMC](#) [[pmc.ncbi.nlm.nih.gov](http://pmc.ncbi.nlm.nih.gov)]
- [7. c-Cbl and Cbl-b ubiquitin ligases: substrate diversity and the negative regulation of signalling responses - PMC](#) [[pmc.ncbi.nlm.nih.gov](http://pmc.ncbi.nlm.nih.gov)]

- [8. Ubiquitin Ligases CBL and CBL-B Maintain the Homeostasis and Immune Quiescence of Dendritic Cells - PMC \[pmc.ncbi.nlm.nih.gov\]](#)
- [9. Screening tools for CBL activity | TR-FRET Assay Kit | BPS Bioscience \[bio-connect.nl\]](#)
- To cite this document: BenchChem. [Assessing Downstream Signaling of Cbl-b Degradation: A Comparative Guide]. BenchChem, [2026]. [Online PDF]. Available at: [<https://www.benchchem.com/product/b15575071/docs#assessing-downstream-signaling-of-cbl-b-degradation-a-comparative-guide>]

### Disclaimer & Data Validity:

The information provided in this document is for Research Use Only (RUO) and is strictly not intended for diagnostic or therapeutic procedures. While BenchChem strives to provide accurate protocols, we make no warranties, express or implied, regarding the fitness of this product for every specific experimental setup.

**Technical Support:** The protocols provided are for reference purposes. Unsure if this reagent suits your experiment?

**Need Industrial/Bulk Grade?** [Request Custom Synthesis Quote](#)

## BenchChem

Our mission is to be the trusted global source of essential and advanced chemicals, empowering scientists and researchers to drive progress in science and industry.

### Contact

Address: 3281 E Guasti Rd  
Ontario, CA 91761, United States  
Phone: (601) 213-4426  
Email: [info@benchchem.com](mailto:info@benchchem.com)

[Contact our Ph.D. Support Team for a compatibility check](#)

