

ZG-2291 (ZG02) and its Effects on Metabolic Dysfunction: A Technical Guide

Author: BenchChem Technical Support Team. **Date:** April 2026

Compound of Interest

Compound Name: ZG-2291
Cat. No.: B15573515

[Get Quote](#)

For Researchers, Scientists, and Drug Development Professionals

Introduction

Metabolic dysfunction, characterized by a cluster of conditions including insulin resistance, hyperglycemia, and dyslipidemia, represents a significant global health challenge. The pursuit of novel therapeutic agents to combat this complex pathophysiology is a paramount goal in drug discovery. This technical guide focuses on the preclinical evidence surrounding ZG02, a tetrahydrocarbazole derivative that has demonstrated potential in ameliorating metabolic dysfunction. While the initial query referenced **ZG-2291**, the available scientific literature points to ZG02 as the compound of interest in this therapeutic area. This document provides a comprehensive overview of the core data, experimental protocols, and mechanistic insights into ZG02's effects on metabolic health.

Core Data Presentation: In Vivo Efficacy of ZG02

The primary in vivo study on ZG02 was conducted using a high-fat diet/streptozotocin-induced type 2 diabetes mouse model. The quantitative outcomes of this study are summarized below for clear comparison.

Table 1: Effects of ZG02 on Body Weight and Glycemic Control in a Type 2 Diabetes Mouse Model[1][2]

Parameter	Control Group	Diabetes Group	ZG02-Treated Group
Body Weight (g)	Normal	Significantly Increased	Significantly Restored
Fasting Blood Glucose (FBG)	Normal	Significantly Increased	Significantly Decreased
Oral Glucose Tolerance Test (OGTT)	Normal Glucose Clearance	Impaired Glucose Clearance	Improved Glucose Clearance
Fasting Serum Insulin	Normal	Significantly Increased	Restored towards Normal
HOMA-IR	Normal	Significantly Increased	Significantly Lowered

Table 2: Effects of ZG02 on Hepatic Glucose Metabolism in a Type 2 Diabetes Mouse Model[1][2]

Parameter	Control Group	Diabetes Group	ZG02-Treated Group
G6PC Activity in Liver	Normal	Significantly Increased	Significantly Lowered
p-AMPK Protein Expression	Normal	Decreased	Significantly Restored
Sirt1 Protein Expression	Normal	Decreased	Significantly Restored
PGC-1 α Protein Expression	Normal	Decreased	Significantly Restored

Potential Effects on Lipid Metabolism (Inferred)

While direct experimental data on the effects of ZG02 on lipid profiles are not yet available, its mechanism of action through the activation of the AMPK/Sirt1/PGC-1 α pathway allows for

informed inferences. Activation of this pathway is well-documented to play a crucial role in lipid metabolism.

- **AMPK Activation:** Generally leads to the inhibition of fatty acid and cholesterol synthesis while promoting fatty acid oxidation.[1] It can reduce triglyceride synthesis and VLDL secretion from the liver.
- **SIRT1 Activation:** Is known to promote lipolysis and fatty acid oxidation.
- **PGC-1 α Activation:** Plays a pivotal role in upregulating genes involved in fatty acid oxidation.

Based on these established roles, it is hypothesized that ZG02 may contribute to an improved lipid profile by reducing circulating triglycerides and cholesterol, and decreasing hepatic steatosis. Further studies are warranted to confirm these potential effects.

Experimental Protocols

High-Fat Diet/Streptozotocin-Induced Type 2 Diabetes Mouse Model

This model is designed to mimic the pathophysiology of type 2 diabetes, which involves both insulin resistance and subsequent β -cell dysfunction.

- **Animal Model:** Male C57BL/6 mice are typically used.
- **Diet-Induced Insulin Resistance:** Mice are fed a high-fat diet (HFD) for a period of 8-12 weeks to induce obesity and insulin resistance.
- **Induction of Hyperglycemia:** Following the HFD period, a low dose of streptozotocin (STZ), a pancreatic β -cell toxin, is administered via intraperitoneal injection. A single high dose (e.g., 95 mg/kg) or multiple low doses (e.g., 40 mg/kg for 5 consecutive days) can be used.
- **Confirmation of Diabetes:** The diabetic state is confirmed by monitoring fasting blood glucose levels, which are typically elevated above a certain threshold (e.g., >250 mg/dL).
- **Treatment:** The ZG02 group receives the compound via intraperitoneal injection at a specified dose (e.g., 30 mg/kg/day) for a defined period (e.g., two weeks).

Biochemical and Molecular Analyses

- Fasting Blood Glucose (FBG): Blood is collected from the tail vein after an overnight fast, and glucose levels are measured using a glucometer.
- Oral Glucose Tolerance Test (OGTT): After an overnight fast, mice are administered an oral gavage of glucose solution. Blood glucose levels are then measured at various time points (e.g., 0, 30, 60, 90, and 120 minutes) to assess glucose clearance.
- Serum Insulin and HOMA-IR: Fasting blood samples are collected, and serum insulin levels are determined using an ELISA kit. The Homeostatic Model Assessment of Insulin Resistance (HOMA-IR) is calculated using the formula: $\text{HOMA-IR} = [\text{Fasting Insulin } (\mu\text{U/L}) \times \text{Fasting Glucose (mmol/L)}] / 22.5$.
- Glucose-6-Phosphatase (G6PC) Activity: Liver tissue is homogenized, and the enzymatic activity of G6PC is measured using a commercially available assay kit.
- Western Blot Analysis: Liver tissue lysates are prepared, and protein concentrations are determined. Equal amounts of protein are separated by SDS-PAGE, transferred to a membrane, and incubated with primary antibodies against total AMPK, phosphorylated AMPK (p-AMPK), Sirt1, and PGC-1 α . Following incubation with secondary antibodies, the protein bands are visualized and quantified.

Mandatory Visualizations

Signaling Pathway of ZG02 in Metabolic Regulation

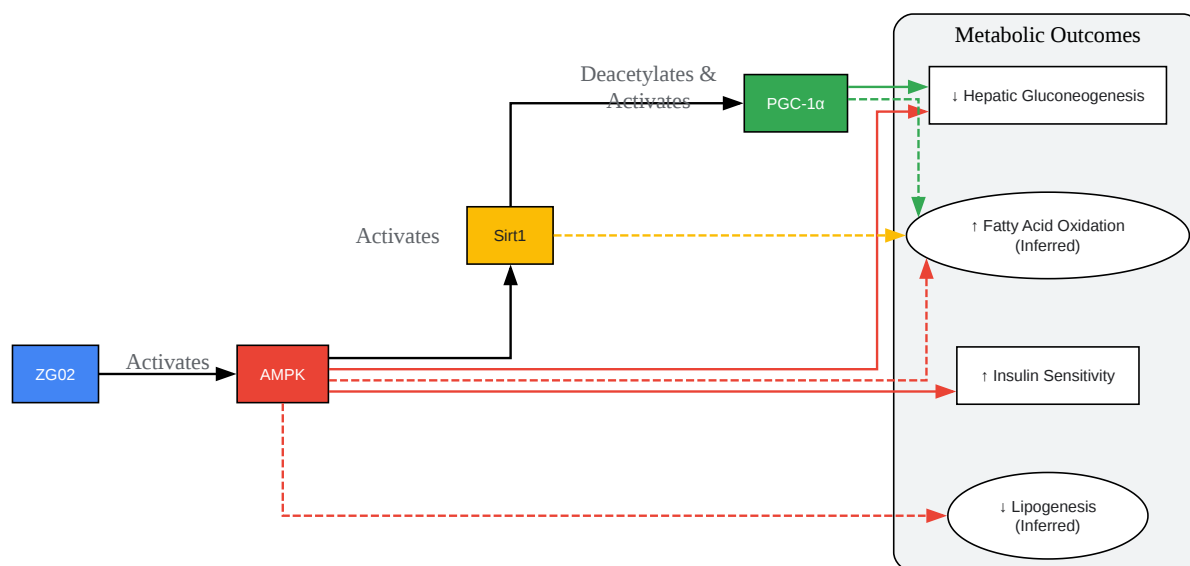

[Click to download full resolution via product page](#)

Caption: Proposed signaling cascade of ZG02 in improving metabolic function.

Experimental Workflow for In Vivo Efficacy Testing of ZG02

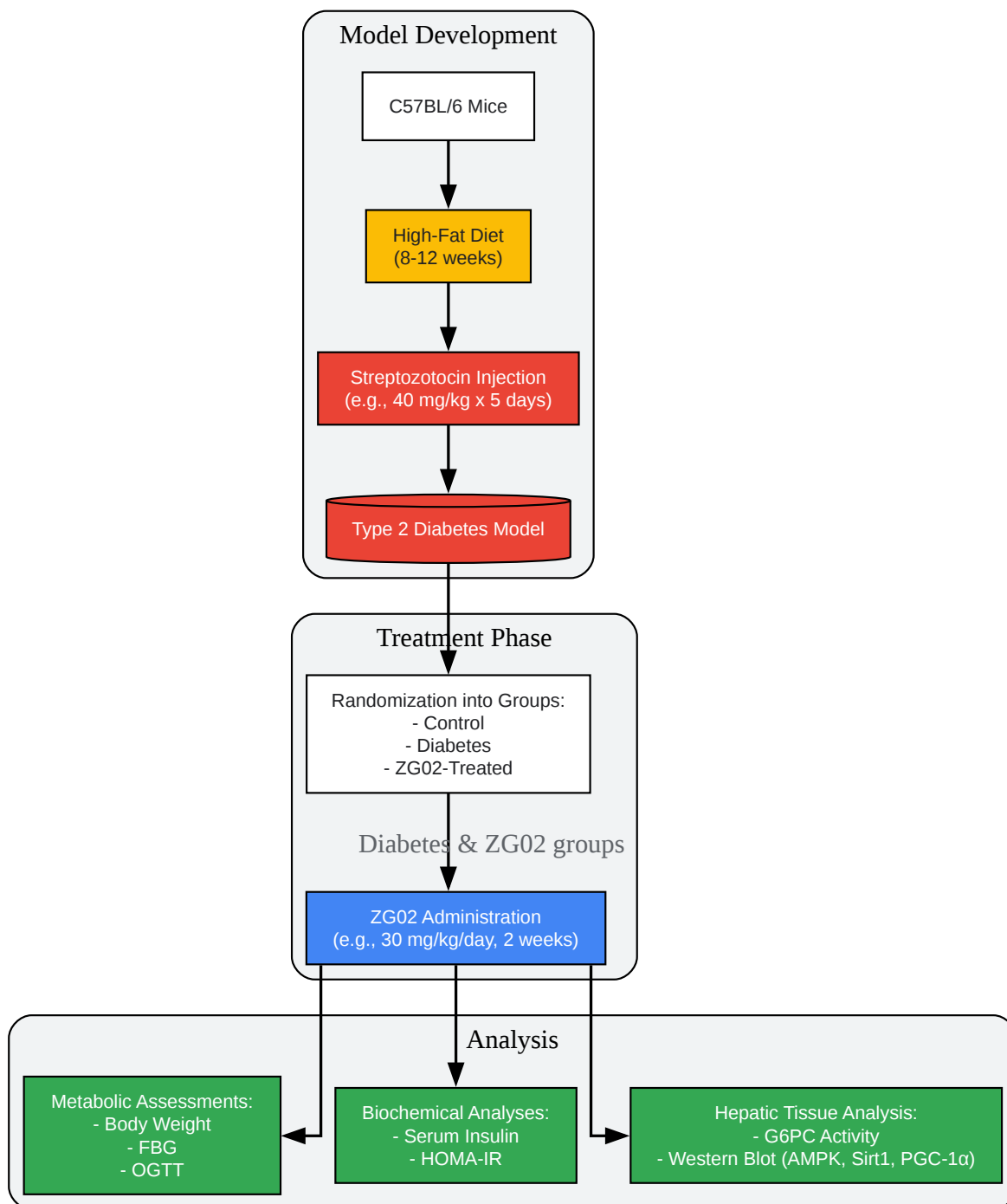

[Click to download full resolution via product page](#)

Caption: Workflow for evaluating ZG02's efficacy in a diabetic mouse model.

Conclusion

ZG02, a novel tetrahydrocarbazole derivative, demonstrates significant potential as a therapeutic agent for metabolic dysfunction. Preclinical data strongly indicate its ability to improve glucose metabolism and enhance insulin sensitivity in a type 2 diabetes model. The mechanism of action appears to be mediated through the activation of the AMPK/Sirt1/PGC-1 α signaling pathway, a critical regulator of cellular energy homeostasis. While further research is required to elucidate its specific effects on lipid metabolism, the known functions of its molecular targets suggest a favorable impact on lipid profiles. The detailed experimental protocols provided herein offer a framework for the continued investigation and development of ZG02 and similar compounds for the treatment of metabolic diseases.

Need Custom Synthesis?

BenchChem offers custom synthesis for rare earth carbides and specific isotopic labeling.

Email: info@benchchem.com or [Request Quote Online](#).

References

- [1. AMP-activated protein kinase: an emerging drug target to regulate imbalances in lipid and carbohydrate metabolism to treat cardio-metabolic diseases: Thematic Review Series: New Lipid and Lipoprotein Targets for the Treatment of Cardiometabolic Diseases - PMC \[pmc.ncbi.nlm.nih.gov\]](#)
- To cite this document: BenchChem. [ZG-2291 (ZG02) and its Effects on Metabolic Dysfunction: A Technical Guide]. BenchChem, [2026]. [Online PDF]. Available at: [\[https://www.benchchem.com/product/b15573515/docs#zg-2291-zg02-and-its-effects-on-metabolic-dysfunction-a-technical-guide\]](https://www.benchchem.com/product/b15573515/docs#zg-2291-zg02-and-its-effects-on-metabolic-dysfunction-a-technical-guide)

Disclaimer & Data Validity:

The information provided in this document is for Research Use Only (RUO) and is strictly not intended for diagnostic or therapeutic procedures. While BenchChem strives to provide accurate protocols, we make no warranties, express or implied, regarding the fitness of this product for every specific experimental setup.

Technical Support: The protocols provided are for reference purposes. Unsure if this reagent suits your experiment?

Need Industrial/Bulk Grade? [Request Custom Synthesis Quote](#)

BenchChem

Our mission is to be the trusted global source of essential and advanced chemicals, empowering scientists and researchers to drive progress in science and industry.

Contact

Address: 3281 E Guasti Rd
Ontario, CA 91761, United States
Phone: (601) 213-4426
Email: info@benchchem.com

[Contact our Ph.D. Support Team for a compatibility check](#)