

# Technical Support Center: Long-Term GIMAP4 Silencing

**Author:** BenchChem Technical Support Team. **Date:** April 2026

## Compound of Interest

Compound Name:	<i>GIMAP4 Human Pre-designed siRNA Set A</i>
Cat. No.:	<i>B15573996</i>

[Get Quote](#)

This technical support center provides researchers, scientists, and drug development professionals with comprehensive troubleshooting guides and frequently asked questions (FAQs) for challenges encountered during long-term GIMAP4 silencing experiments.

## Troubleshooting Guides

This section addresses specific issues that may arise during your long-term GIMAP4 silencing experiments, offering potential causes and solutions in a question-and-answer format.

Issue ID	Question	Potential Causes	Recommended Solutions
GIMAP4-TS-001	I am not observing significant GIMAP4 knockdown after antibiotic selection of my shRNA-transduced cells.	<p>1. Inefficient Lentiviral Transduction: Low viral titer or suboptimal transduction conditions.</p> <p>2. Ineffective shRNA Sequence: The chosen shRNA sequence may not efficiently target GIMAP4 mRNA.</p> <p>3. Incorrect Antibiotic Concentration: The concentration of the selection antibiotic (e.g., puromycin) may be too low, allowing non-transduced cells to survive.</p> <p>4. Improper Assay for Knockdown Assessment: Issues with qPCR primers or Western blot antibodies.</p>	<p>1. Optimize Transduction: Titer your lentivirus and optimize the multiplicity of infection (MOI). Use transduction enhancers like Polybrene.</p> <p>2. Test Multiple shRNAs: It is recommended to test 3-4 different shRNA sequences targeting GIMAP4 to identify the most effective one.</p> <p>3. Determine Optimal Antibiotic Concentration: Perform an antibiotic titration (kill curve) on your specific cell line to determine the minimum concentration required for effective selection.</p> <p>4. Validate Assays: Ensure your qPCR primers are specific and efficient. For Western blotting, validate your GIMAP4 antibody and include appropriate controls.</p>

GIMAP4-TS-002	My cells show high levels of cell death after transduction with GIMAP4 shRNA lentivirus, even before antibiotic selection.	<p>1. Lentiviral Toxicity: High viral loads can be toxic to some cell lines. 2. GIMAP4's Pro-apoptotic Function: Silencing GIMAP4 may sensitize cells to apoptosis, and the stress of transduction could be enough to trigger cell death.<sup>[1]</sup></p>	<p>1. Reduce Viral Titer: Use the lowest effective MOI that achieves good transduction efficiency. 2. Reduce Transduction Time: Shorten the incubation time with the virus (e.g., 4-8 hours instead of overnight). 3. Use a Healthier Cell Population: Ensure cells are in a logarithmic growth phase and not overly confluent at the time of transduction.</p>
GIMAP4-TS-003	I initially see good GIMAP4 knockdown, but the expression level recovers over time in my stable cell line.	<p>1. Loss of shRNA Expression: The integrated lentiviral construct may be silenced over time through epigenetic modifications. 2. Selection of Resistant Cells: A subpopulation of cells with lower shRNA expression or compensatory mechanisms may be outcompeting the well-silenced cells. 3. Loss of Vector Genomes: Long-term expression of shRNA can sometimes lead to the</p>	<p>1. Re-select the Cell Population: Periodically culture the cells in the selection antibiotic to eliminate cells that have lost shRNA expression. 2. Single-Cell Cloning: Isolate and expand single-cell clones to establish a truly homogenous stable cell line. 3. Monitor shRNA Expression: Use qPCR to periodically check the expression level of the shRNA itself.</p>

		<p>loss of the integrated viral vector.<a href="#">[2]</a><a href="#">[3]</a></p>	
<p>GIMAP4-TS-004</p>	<p>Silencing GIMAP4 does not produce the expected apoptotic phenotype in my cells.</p>	<p>1. Compensatory Mechanisms: Cells may upregulate other anti-apoptotic or pro-survival pathways to compensate for the loss of GIMAP4. This can include other Bcl-2 family proteins.<a href="#">[4]</a><a href="#">[5]</a></p> <p>2. Cell Line-Specific Differences: The role of GIMAP4 in apoptosis may be context-dependent and vary between different cell types.</p> <p>3. Incomplete Knockdown: Residual GIMAP4 expression may be sufficient to maintain its function.</p>	<p>1. Investigate Compensatory Pathways: Use techniques like RNA-seq or proteomics to identify upregulated genes or proteins in your GIMAP4-silenced cells. Consider co-silencing of potential compensatory targets.</p> <p>2. Confirm GIMAP4's Role in Your System: Before long-term studies, perform transient knockdown experiments to confirm the expected phenotype in your specific cell line.</p> <p>3. Aim for Higher Knockdown Efficiency: Screen for more potent shRNA sequences or consider using a CRISPR-Cas9 knockout approach for complete gene ablation.</p>
<p>GIMAP4-TS-005</p>	<p>I am observing unexpected phenotypic changes in my GIMAP4-silenced</p>	<p>1. Off-Target Effects: The shRNA may be silencing other unintended genes.<a href="#">[6]</a></p> <p>2. Saturation of the</p>	<p>1. Perform Rescue Experiments: Re-introduce a GIMAP4 expression vector that is resistant to your</p>

cells that don't seem related to apoptosis.

RNAi Machinery: Overexpression of shRNA can interfere with the processing of endogenous microRNAs, leading to widespread changes in gene expression.[6]

shRNA. If the phenotype is rescued, it is likely on-target. 2. Use Off-Target Prediction Tools: Utilize bioinformatics tools to predict potential off-target effects of your shRNA sequence. 3. Use a Different shRNA: Test another shRNA targeting a different region of the GIMAP4 mRNA. If the phenotype is consistent, it is more likely to be on-target. 4. Use the Lowest Effective shRNA Dose: Use a weaker promoter or a lower MOI to minimize saturation of the RNAi machinery.

---

## Frequently Asked Questions (FAQs)

### 1. What is the known function of GIMAP4?

GIMAP4, or GTPase of the immunity-associated protein family member 4, is primarily expressed in immune cells. It is known to play a role in regulating T-cell apoptosis. Specifically, it has been shown to accelerate programmed cell death induced by intrinsic stimuli, acting downstream of caspase-3 activation.[1] GIMAP4 is a cytosolic protein that can associate with the pro-apoptotic protein Bax.[7][8]

### 2. What are the main challenges in long-term GIMAP4 silencing?

The primary challenges include:

- **Cell Viability Issues:** Due to GIMAP4's role in apoptosis, its long-term absence may alter the sensitivity of cells to various stressors.
- **Compensatory Responses:** Cells may adapt to the loss of GIMAP4 by upregulating other genes involved in cell survival and apoptosis regulation.
- **Off-Target Effects:** The shRNA used to silence GIMAP4 may inadvertently affect the expression of other genes, leading to confounding results.
- **Instability of Knockdown:** The silencing effect may diminish over time due to epigenetic silencing of the shRNA expression cassette or selection against cells with strong knockdown.

### 3. How can I validate the knockdown of GIMAP4?

GIMAP4 knockdown should be validated at both the mRNA and protein levels.

- **mRNA Level:** Quantitative real-time PCR (qPCR) is the most common method. Design primers that span an exon-exon junction to avoid amplification of genomic DNA.
- **Protein Level:** Western blotting is used to detect the reduction in GIMAP4 protein. It is crucial to use a specific and validated antibody for GIMAP4.

### 4. What controls should I use in my GIMAP4 silencing experiments?

Proper controls are essential for interpreting your results accurately.

- **Negative Controls:**
  - **Non-transduced cells:** To assess the baseline phenotype.
  - **Scrambled shRNA:** A lentiviral vector expressing an shRNA sequence that does not target any known gene in your model system. This controls for the effects of viral transduction and shRNA expression.
- **Positive Control (for the experimental system):**

- An shRNA known to effectively knock down a different, well-characterized gene in your cell line. This confirms that your transduction and selection procedures are working.
- Rescue Experiment:
  - Re-expressing a silencing-resistant form of GIMAP4 in your knockdown cells to confirm that the observed phenotype is specifically due to the loss of GIMAP4.

## 5. Should I use shRNA or CRISPR-Cas9 for long-term GIMAP4 silencing?

The choice between shRNA and CRISPR-Cas9 depends on your experimental goals.

- shRNA (knockdown): Reduces the expression of GIMAP4. This is often sufficient for many studies and can be advantageous if complete loss of the protein is lethal. However, residual protein expression can sometimes complicate the interpretation of results.
- CRISPR-Cas9 (knockout): Completely ablates the GIMAP4 gene, leading to a total loss of protein expression. This provides a more definitive loss-of-function model but may be more likely to induce compensatory mechanisms.

## Experimental Protocols

### Lentiviral shRNA Transduction and Stable Cell Line Selection

This protocol describes the steps for transducing your target cells with lentiviral particles carrying a GIMAP4-specific shRNA and selecting for a stable cell line.

Materials:

- Target cells
- Lentiviral particles (GIMAP4 shRNA and scrambled control)
- Complete culture medium
- Polybrene (transduction enhancer)

- Selection antibiotic (e.g., puromycin)
- 96-well and 6-well tissue culture plates

Procedure:

- Day 1: Cell Seeding
  - Plate your target cells in a 6-well plate at a density that will result in 50-70% confluency on the day of transduction.
  - Incubate overnight at 37°C, 5% CO<sub>2</sub>.
- Day 2: Transduction
  - Thaw the lentiviral particles on ice.
  - Prepare your transduction medium by adding Polybrene to the complete culture medium at a final concentration of 4-8 µg/mL.
  - Aspirate the old medium from your cells and replace it with the transduction medium.
  - Add the lentiviral particles to the cells at the desired MOI. Gently swirl the plate to mix.
  - Incubate overnight at 37°C, 5% CO<sub>2</sub>.
- Day 3: Medium Change
  - Aspirate the virus-containing medium and replace it with fresh, complete culture medium.
- Day 4 onwards: Antibiotic Selection
  - After 24-48 hours post-transduction, aspirate the medium and replace it with complete culture medium containing the appropriate concentration of selection antibiotic (previously determined by a kill curve).
  - Replace the selection medium every 2-3 days.
  - Monitor the cells daily. Non-transduced cells should die off within 3-7 days.

- Once resistant colonies are visible, you can either pool them to create a polyclonal stable cell line or isolate individual colonies to establish monoclonal stable cell lines.

## MTT Cell Viability Assay

This colorimetric assay measures the metabolic activity of cells, which is an indicator of cell viability.

Materials:

- Cells cultured in a 96-well plate
- MTT (3-(4,5-dimethylthiazol-2-yl)-2,5-diphenyltetrazolium bromide) solution (5 mg/mL in PBS)
- DMSO or solubilization buffer
- Microplate reader

Procedure:

- Plate your GIMAP4-silenced and control cells in a 96-well plate and treat them as required for your experiment.
- At the end of the treatment period, add 10  $\mu$ L of MTT solution to each well.[\[9\]](#)
- Incubate the plate for 2-4 hours at 37°C, allowing viable cells to convert the MTT into formazan crystals.
- Aspirate the medium containing MTT and add 100  $\mu$ L of DMSO or a solubilization solution to each well to dissolve the formazan crystals.[\[10\]](#)
- Shake the plate gently for 15 minutes to ensure complete solubilization.
- Measure the absorbance at 570 nm using a microplate reader.[\[11\]](#)

## Western Blot for GIMAP4 Protein Expression

This protocol outlines the detection of GIMAP4 protein levels in cell lysates.

**Materials:**

- Cell lysates from GIMAP4-silenced and control cells
- RIPA buffer with protease inhibitors
- BCA protein assay kit
- SDS-PAGE gels
- Transfer buffer and membrane (PVDF or nitrocellulose)
- Blocking buffer (e.g., 5% non-fat milk in TBST)
- Primary antibody (anti-GIMAP4)
- HRP-conjugated secondary antibody
- Chemiluminescent substrate
- Imaging system

**Procedure:**

- Protein Extraction and Quantification:
  - Lyse cells in RIPA buffer on ice.
  - Centrifuge to pellet cell debris and collect the supernatant.
  - Determine the protein concentration of each lysate using a BCA assay.
- SDS-PAGE and Transfer:
  - Normalize the protein concentration for all samples and prepare them with Laemmli buffer.
  - Load equal amounts of protein onto an SDS-PAGE gel and run the electrophoresis.
  - Transfer the separated proteins to a membrane.

- Immunoblotting:
  - Block the membrane in blocking buffer for 1 hour at room temperature.[\[12\]](#)
  - Incubate the membrane with the primary anti-GIMAP4 antibody overnight at 4°C.
  - Wash the membrane three times with TBST.
  - Incubate with the HRP-conjugated secondary antibody for 1 hour at room temperature.
  - Wash the membrane three times with TBST.
- Detection:
  - Apply the chemiluminescent substrate and capture the signal using an imaging system.
  - Re-probe the membrane with an antibody against a loading control (e.g., GAPDH or  $\beta$ -actin) to ensure equal protein loading.

## qPCR for GIMAP4 Gene Expression

This protocol is for quantifying the relative expression of GIMAP4 mRNA.

Materials:

- RNA extracted from GIMAP4-silenced and control cells
- cDNA synthesis kit
- SYBR Green qPCR master mix
- GIMAP4-specific forward and reverse primers
- Reference gene-specific primers (e.g., GAPDH, ACTB)
- qPCR instrument

Procedure:

- RNA Extraction and cDNA Synthesis:
  - Extract total RNA from your cell samples.
  - Synthesize cDNA from the RNA using a reverse transcription kit.
- qPCR Reaction Setup:
  - Prepare the qPCR reaction mix containing SYBR Green master mix, forward and reverse primers, and cDNA template.
  - Set up reactions for both GIMAP4 and a reference gene in triplicate for each sample.
  - Include a no-template control for each primer set.
- qPCR Run:
  - Run the qPCR plate on a real-time PCR instrument using a standard cycling protocol (e.g., initial denaturation, followed by 40 cycles of denaturation, annealing, and extension).
- Data Analysis:
  - Determine the Ct (cycle threshold) values for each reaction.
  - Calculate the relative expression of GIMAP4 using the  $\Delta\Delta C_t$  method, normalizing to the reference gene and comparing to the scrambled shRNA control.

## Visualizations

### GIMAP4 in the Intrinsic Apoptosis Pathway

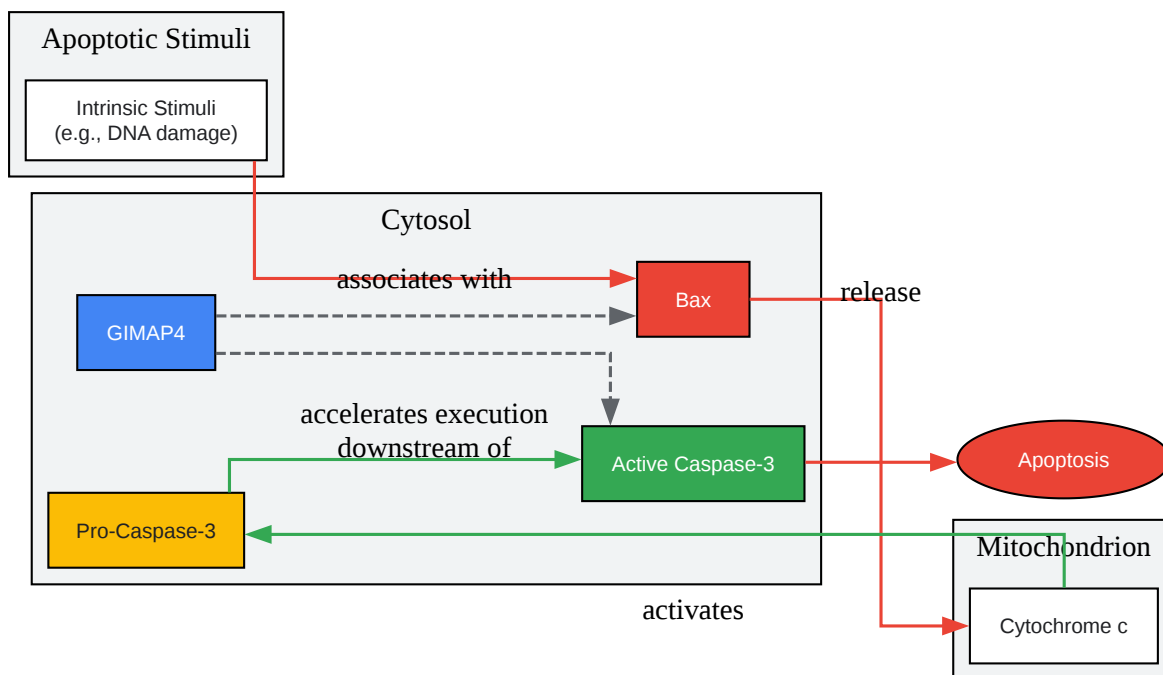

[Click to download full resolution via product page](#)

Caption: GIMAP4's role in the intrinsic apoptosis pathway.

## Experimental Workflow for Long-Term GIMAP4 Silencing

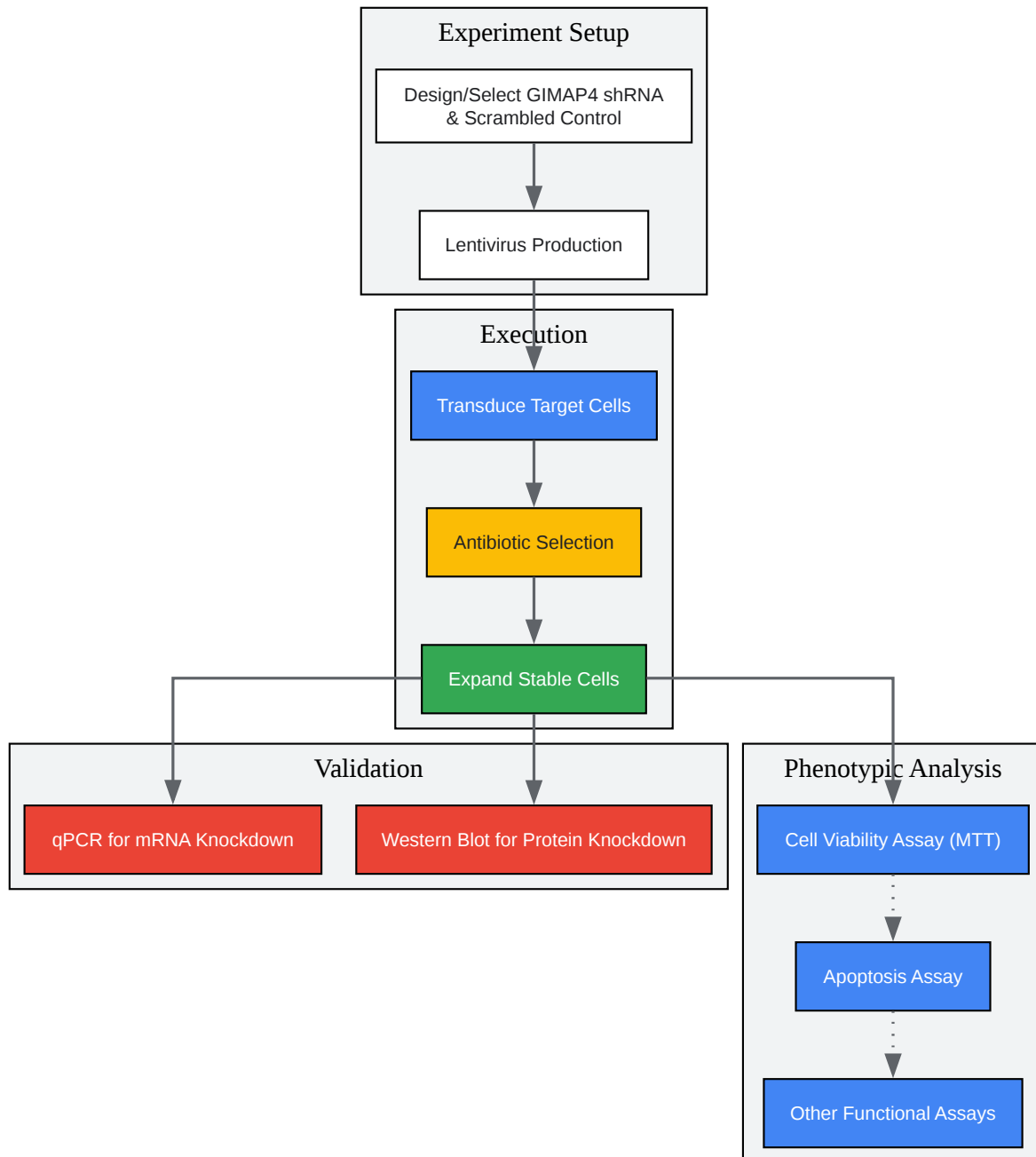

[Click to download full resolution via product page](#)

Caption: Workflow for generating and analyzing GIMAP4 stable knockdown cell lines.

## IFN- $\gamma$ Signaling Pathway Leading to Gene Expression

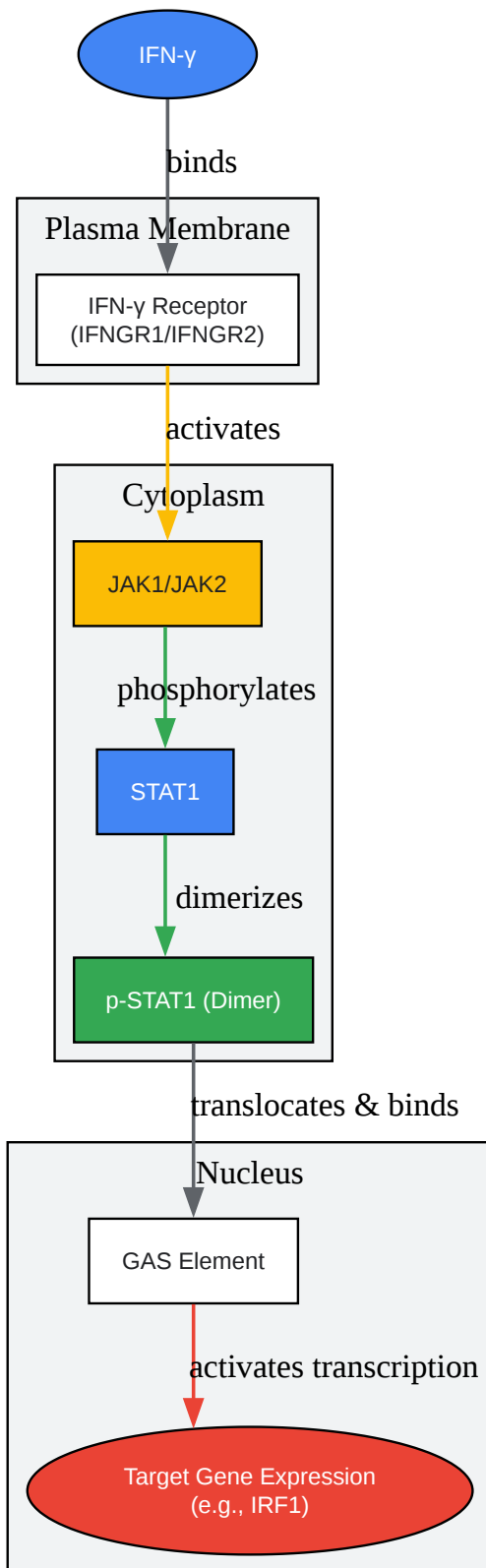

[Click to download full resolution via product page](#)

Caption: Overview of the canonical IFN- $\gamma$  JAK-STAT signaling pathway.

### Need Custom Synthesis?

BenchChem offers custom synthesis for rare earth carbides and specific isotopic labeling.

Email: [info@benchchem.com](mailto:info@benchchem.com) or [Request Quote Online](#).

## References

- 1. Gimap4 accelerates T-cell death - PubMed [[pubmed.ncbi.nlm.nih.gov](https://pubmed.ncbi.nlm.nih.gov)]
- 2. [researchgate.net](https://researchgate.net) [[researchgate.net](https://researchgate.net)]
- 3. Constitutive Expression of Short Hairpin RNA in Vivo Triggers Buildup of Mature Hairpin Molecules - PMC [[pubmed.ncbi.nlm.nih.gov](https://pubmed.ncbi.nlm.nih.gov)]
- 4. Apoptosis: a Janus bifrons in T-cell immunotherapy - PMC [[pubmed.ncbi.nlm.nih.gov](https://pubmed.ncbi.nlm.nih.gov)]
- 5. Unlocking Apoptotic Pathways: Overcoming Tumor Resistance in CAR-T-Cell Therapy - PMC [[pubmed.ncbi.nlm.nih.gov](https://pubmed.ncbi.nlm.nih.gov)]
- 6. RISC- $\gamma$  Business: Limitations of Short Hairpin RNA-Mediated Gene Silencing in the Brain and a Discussion of CRISPR/Cas-Based Alternatives - PMC [[pubmed.ncbi.nlm.nih.gov](https://pubmed.ncbi.nlm.nih.gov)]
- 7. GIMAP Proteins in T-Lymphocytes - PMC [[pubmed.ncbi.nlm.nih.gov](https://pubmed.ncbi.nlm.nih.gov)]
- 8. [researchgate.net](https://researchgate.net) [[researchgate.net](https://researchgate.net)]
- 9. [merckmillipore.com](https://www.merckmillipore.com) [[merckmillipore.com](https://www.merckmillipore.com)]
- 10. MTT (Assay protocol [[protocols.io](https://www.protocols.io)])
- 11. CyQUANT MTT Cell Proliferation Assay Kit Protocol | Thermo Fisher Scientific - JP [[thermofisher.com](https://www.thermofisher.com)]
- 12. Western blot protocol | Abcam [[abcam.com](https://www.abcam.com)]
- To cite this document: BenchChem. [Technical Support Center: Long-Term GIMAP4 Silencing]. BenchChem, [2026]. [Online PDF]. Available at: [<https://www.benchchem.com/product/b15573996/docs#technical-support-center-long-term-gimap4-silencing>]

---

### Disclaimer & Data Validity:

The information provided in this document is for Research Use Only (RUO) and is strictly not intended for diagnostic or therapeutic procedures. While BenchChem strives to provide accurate protocols, we make no warranties, express or implied, regarding the fitness of this product for every specific experimental setup.

**Technical Support:** The protocols provided are for reference purposes. Unsure if this reagent suits your experiment?

**Need Industrial/Bulk Grade?** [Request Custom Synthesis Quote](#)

## BenchChem

Our mission is to be the trusted global source of essential and advanced chemicals, empowering scientists and researchers to drive progress in science and industry.

### Contact

Address: 3281 E Guasti Rd  
Ontario, CA 91761, United States  
Phone: (601) 213-4426  
Email: [info@benchchem.com](mailto:info@benchchem.com)

[Contact our Ph.D. Support Team for a compatibility check](#)