

Independent Validation of Leuhistin: A Comparative Guide for Researchers

Author: BenchChem Technical Support Team. **Date:** April 2026

Compound of Interest

Compound Name: *Leuhistin*
CAS No.: *147384-45-0*
Cat. No.: *B15573889*

[Get Quote](#)

For Researchers, Scientists, and Drug Development Professionals: An Objective Comparison of **Leuhistin**'s Performance Against Alternative Aminopeptidase M Inhibitors, with Supporting Experimental Data and Protocols.

This guide provides an independent validation of published data on **Leuhistin**, a potent inhibitor of Aminopeptidase M (AP-M, also known as CD13). We offer a direct comparison with other well-characterized inhibitors, present detailed experimental protocols for key assays, and visualize the complex signaling pathways associated with this important therapeutic target. All data is summarized for clear, comparative analysis.

Comparative Analysis of Aminopeptidase M/N Inhibitors

Leuhistin, a natural product isolated from *Bacillus laterosporus*, is a competitive inhibitor of Aminopeptidase M. For a comprehensive evaluation, its inhibitory constant (K_i) is compared with those of other prominent aminopeptidase inhibitors: Bestatin, Actinonin, and Probestin. The following tables summarize their reported inhibitory activities against Aminopeptidase M/N and other related aminopeptidases.

Inhibitor	Target Enzyme	K _i (Inhibition Constant)
Leuhistin	Aminopeptidase M (AP-M)	2.3 x 10 ⁻⁷ M (230 nM)
Probestin	Aminopeptidase M (AP-M)	1.9 x 10 ⁻⁸ M (19 nM)[1]
Bestatin	Aminopeptidase M (AP-M)	4.1 x 10 ⁻⁶ M (4100 nM)
Actinonin	Aminopeptidase N (AP-N)	1.7 x 10 ⁻⁷ M (170 nM)

Inhibitor	Target Enzyme	IC ₅₀ (Half-maximal Inhibitory Concentration)
Bestatin	Aminopeptidase N (AP-N)	5 nM
Bestatin	Leucine Aminopeptidase	20 nM
Bestatin	Aminopeptidase B	60 nM
Actinonin	Aminopeptidase M (AP-M), Aminopeptidase N (AP-N), Leucine Aminopeptidase	Not specified in provided results
Probestin	Aminopeptidase M (AP-M)	Not specified in provided results

Experimental Protocols

To facilitate the independent validation of these findings, detailed methodologies for key experiments are provided below.

Protocol 1: Determination of Inhibitory Activity (K_i/IC₅₀) of Aminopeptidase M/N

This protocol outlines a general procedure for determining the inhibitory potency of compounds like **Leuhistin** against Aminopeptidase M/N.

Materials:

- Purified Aminopeptidase M/N enzyme

- Substrate: L-Leucine-p-nitroanilide or a similar chromogenic/fluorogenic substrate
- Inhibitors: **Leuhistin**, Bestatin, Actinonin, Probestin
- Assay Buffer: e.g., 50 mM Tris-HCl, pH 7.4
- 96-well microplates
- Microplate reader

Procedure:

- Enzyme and Substrate Preparation: Prepare stock solutions of the enzyme and substrate in the assay buffer. The final concentration of the enzyme should be in the linear range of the assay, and the substrate concentration should be at or near its Michaelis-Menten constant (K_m).
- Inhibitor Dilution Series: Prepare a serial dilution of the inhibitor to be tested in the assay buffer.
- Assay Reaction:
 - To each well of a 96-well plate, add the assay buffer.
 - Add the inhibitor at various concentrations.
 - Add the enzyme solution and pre-incubate with the inhibitor for a defined period (e.g., 15-30 minutes) at a controlled temperature (e.g., 37°C).
 - Initiate the reaction by adding the substrate.
- Data Acquisition: Measure the absorbance or fluorescence at regular intervals using a microplate reader to determine the initial reaction velocity.
- Data Analysis:
 - IC_{50} Determination: Plot the reaction velocity against the logarithm of the inhibitor concentration and fit the data to a sigmoidal dose-response curve to calculate the IC_{50}

value.

- Ki Determination: To determine the mode of inhibition and calculate the K_i , perform the assay at multiple substrate concentrations in the presence of different inhibitor concentrations. Analyze the data using Lineweaver-Burk or Dixon plots. For competitive inhibitors like **Leuhistin**, the K_i can be calculated from the IC_{50} value using the Cheng-Prusoff equation: $K_i = IC_{50} / (1 + [S]/K_m)$, where $[S]$ is the substrate concentration and K_m is the Michaelis-Menten constant.

Protocol 2: Analysis of CD13-Mediated Intracellular Calcium Mobilization

Ligation of CD13 on monocytic cells can trigger intracellular signaling independent of its enzymatic activity. This protocol describes how to measure the resulting calcium influx.

Materials:

- Monocytic cell line (e.g., U937)
- Anti-CD13 monoclonal antibody (for cross-linking)
- Secondary cross-linking antibody (e.g., $F(ab')_2$ fragment of goat anti-mouse IgG)
- Calcium-sensitive fluorescent dye (e.g., Fura-2 AM or Indo-1 AM)
- Hanks' Balanced Salt Solution (HBSS) with and without calcium
- Fluorimeter or flow cytometer

Procedure:

- Cell Loading: Incubate the monocytic cells with a calcium-sensitive fluorescent dye in HBSS without calcium for 30-60 minutes at 37°C.
- Washing: Wash the cells twice with HBSS without calcium to remove excess dye.
- Antibody Incubation: Resuspend the cells in HBSS with calcium and incubate with the primary anti-CD13 antibody for 30 minutes on ice.

- **Baseline Measurement:** Measure the baseline fluorescence of the cell suspension.
- **Cross-linking and Measurement:** Add the secondary cross-linking antibody to induce CD13 clustering and immediately begin recording the fluorescence signal over time. An increase in fluorescence indicates a rise in intracellular calcium.
- **Data Analysis:** Quantify the change in fluorescence intensity over time to determine the kinetics and magnitude of the calcium response.

Protocol 3: Detection of MAP Kinase Phosphorylation via Western Blot

This protocol details the detection of phosphorylated ERK1/2, JNK, and p38 MAP kinases following CD13 ligation.

Materials:

- Monocytic cell line
- Anti-CD13 monoclonal antibody and secondary cross-linking antibody
- Lysis buffer (e.g., RIPA buffer) with protease and phosphatase inhibitors
- Primary antibodies: anti-phospho-ERK1/2, anti-phospho-JNK, anti-phospho-p38, and antibodies for total MAP kinases
- HRP-conjugated secondary antibody
- SDS-PAGE gels and Western blot apparatus
- Chemiluminescent substrate

Procedure:

- **Cell Stimulation:** Treat monocytic cells with anti-CD13 antibodies to induce cross-linking for various time points (e.g., 0, 5, 15, 30 minutes).
- **Cell Lysis:** Wash the cells with ice-cold PBS and lyse them with lysis buffer.

- Protein Quantification: Determine the protein concentration of the cell lysates using a BCA or Bradford assay.
- SDS-PAGE and Western Blotting:
 - Separate equal amounts of protein from each sample on an SDS-PAGE gel.
 - Transfer the proteins to a PVDF or nitrocellulose membrane.
- Immunoblotting:
 - Block the membrane with 5% non-fat milk or BSA in TBST.
 - Incubate the membrane with the primary antibody against the phosphorylated MAP kinase overnight at 4°C.
 - Wash the membrane and incubate with the HRP-conjugated secondary antibody.
- Detection: Visualize the protein bands using a chemiluminescent substrate and an imaging system.
- Data Analysis: Quantify the band intensities and normalize the phosphorylated protein levels to the total protein levels for each MAP kinase.

Protocol 4: Quantification of IL-8 mRNA Upregulation by RT-qPCR

This protocol describes how to measure the change in Interleukin-8 (IL-8) gene expression following CD13 stimulation.

Materials:

- Monocytic cell line
- Anti-CD13 monoclonal antibody and secondary cross-linking antibody
- RNA extraction kit

- cDNA synthesis kit
- qPCR primers for IL-8 and a housekeeping gene (e.g., GAPDH)
- qPCR master mix
- Real-time PCR system

Procedure:

- Cell Stimulation: Stimulate monocytic cells by cross-linking CD13 for a specified time (e.g., 2-4 hours).
- RNA Extraction: Isolate total RNA from the cells using a commercial RNA extraction kit.
- cDNA Synthesis: Reverse transcribe the RNA into cDNA using a cDNA synthesis kit.
- Quantitative PCR (qPCR):
 - Set up qPCR reactions using the cDNA, primers for IL-8 and the housekeeping gene, and a qPCR master mix.
 - Run the qPCR reaction in a real-time PCR system.
- Data Analysis: Determine the relative expression of IL-8 mRNA using the comparative Ct ($\Delta\Delta C_t$) method, normalizing the IL-8 expression to the housekeeping gene.

Visualizing the Biological Context

To better understand the mechanisms discussed, the following diagrams illustrate the experimental workflows and the signaling pathway initiated by CD13 ligation.

Experimental Workflow for Aminopeptidase M Inhibition Assay

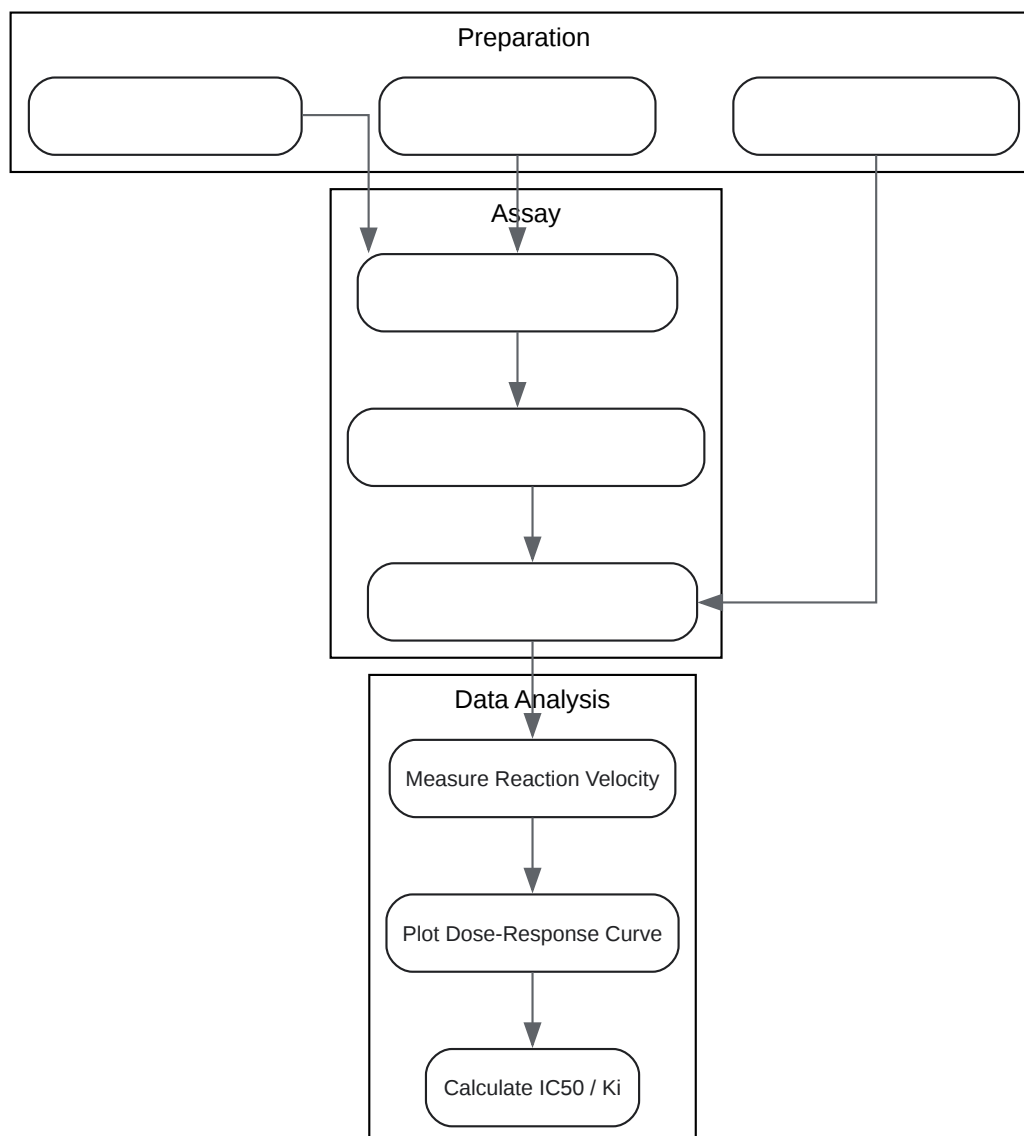

[Click to download full resolution via product page](#)

Caption: Workflow for determining the inhibitory potency of compounds against Aminopeptidase M.

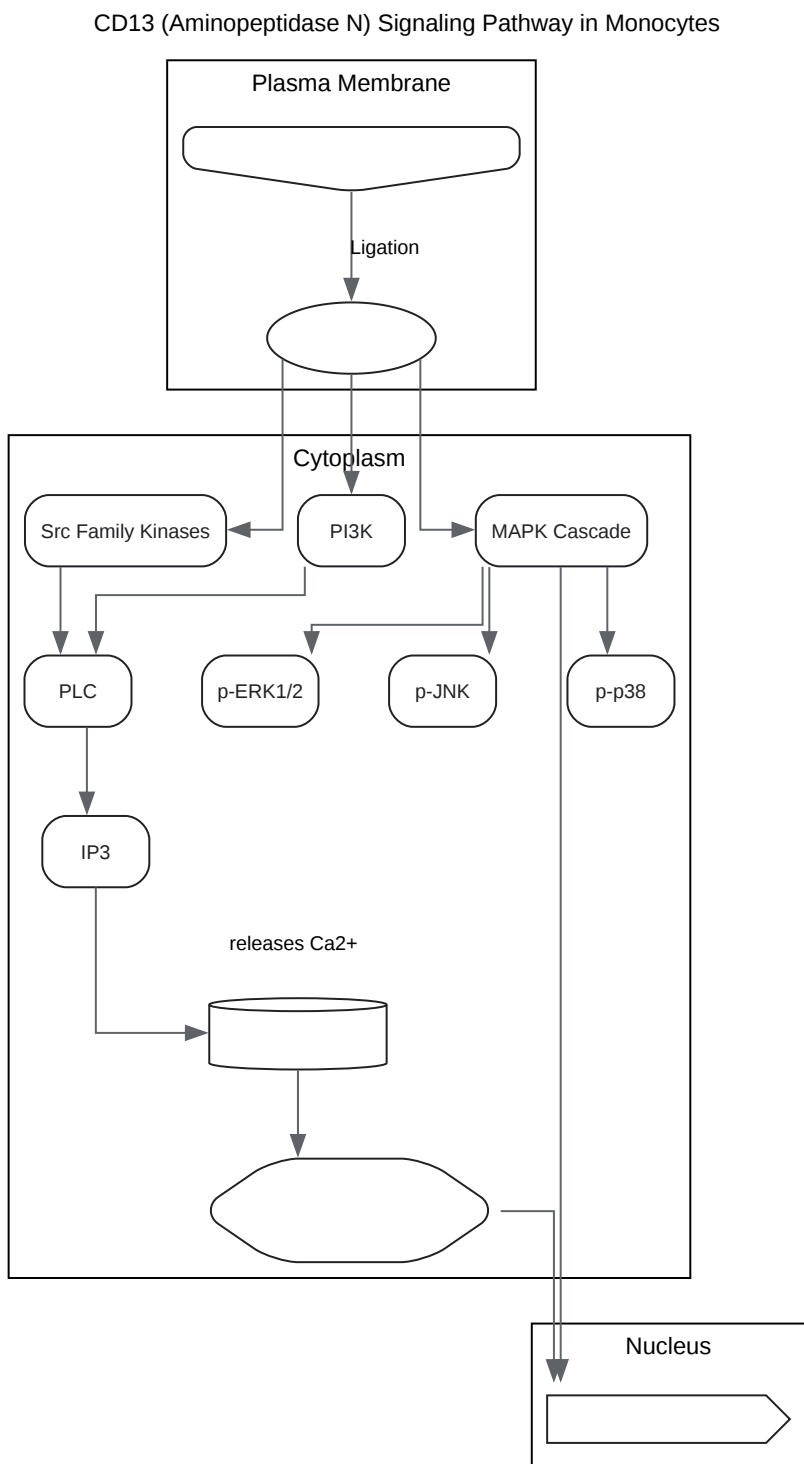

[Click to download full resolution via product page](#)

Caption: Signaling cascade initiated by CD13 ligation, independent of its enzymatic activity.

Need Custom Synthesis?

BenchChem offers custom synthesis for rare earth carbides and specific isotopic labeling.

Email: info@benchchem.com or [Request Quote Online](#).

References

- [1. pubs.acs.org \[pubs.acs.org\]](https://pubs.acs.org)
- To cite this document: BenchChem. [Independent Validation of Leuhistin: A Comparative Guide for Researchers]. BenchChem, [2026]. [Online PDF]. Available at: [\[https://www.benchchem.com/product/b15573889/docs#independent-validation-of-leuhistin-a-comparative-guide-for-researchers\]](https://www.benchchem.com/product/b15573889/docs#independent-validation-of-leuhistin-a-comparative-guide-for-researchers)

Disclaimer & Data Validity:

The information provided in this document is for Research Use Only (RUO) and is strictly not intended for diagnostic or therapeutic procedures. While BenchChem strives to provide accurate protocols, we make no warranties, express or implied, regarding the fitness of this product for every specific experimental setup.

Technical Support: The protocols provided are for reference purposes. Unsure if this reagent suits your experiment?

Need Industrial/Bulk Grade? [Request Custom Synthesis Quote](#)

BenchChem

Our mission is to be the trusted global source of essential and advanced chemicals, empowering scientists and researchers to drive progress in science and industry.

Contact

Address: 3281 E Guasti Rd

Ontario, CA 91761, United States

Phone: (601) 213-4426

Email: info@benchchem.com

[Contact our Ph.D. Support Team for a compatibility check](#)