

# Avoiding interferon response with GIMAP4 siRNA

**Author:** BenchChem Technical Support Team. **Date:** April 2026

## Compound of Interest

Compound Name: *GIMAP4 Human Pre-designed  
siRNA Set A*

Cat. No.: *B15573996*

[Get Quote](#)

## GIMAP4 siRNA Technical Support Center

This technical support center provides troubleshooting guides and frequently asked questions (FAQs) for researchers using GIMAP4 siRNA. The focus is on understanding and mitigating the off-target interferon response, a common issue in RNAi experiments, in the context of studying GIMAP4's role in interferon-gamma (IFN- $\gamma$ ) secretion.

### Frequently Asked Questions (FAQs)

Q1: What is the difference between the intended effect of GIMAP4 siRNA on interferon and the off-target interferon response?

A1: This is a critical distinction. The intended, on-target effect of GIMAP4 siRNA is to silence the GIMAP4 gene. Since GIMAP4 is involved in the secretion of Interferon-gamma (IFN- $\gamma$ , a Type II interferon) in certain immune cells like T helper cells, successful knockdown of GIMAP4 is expected to decrease the amount of secreted IFN- $\gamma$ .<sup>[1][2]</sup> This is the biological phenomenon under investigation.

The off-target effect is an unintended activation of the innate immune system by the siRNA molecule itself. The cell can recognize the double-stranded siRNA as a viral mimic, triggering a Type I interferon (IFN- $\alpha$ , IFN- $\beta$ ) response.[3] This leads to the upregulation of hundreds of interferon-stimulated genes (ISGs), which can cause cellular toxicity, alter experimental results, and is independent of the GIMAP4 gene sequence.

Q2: My cells are showing signs of toxicity (e.g., cell death, reduced proliferation) after transfection with GIMAP4 siRNA. Is this due to the off-target interferon response?

A2: It is highly likely. A strong, off-target Type I interferon response can lead to a global shutdown of protein synthesis and can induce apoptosis, resulting in the observed cytotoxicity. [4] It is crucial to differentiate this from a potential biological role of GIMAP4 in cell survival. To confirm if the toxicity is due to an off-target interferon response, you should measure the expression of key interferon-stimulated genes (ISGs) like OAS1, ISG15, or STAT1 via RT-qPCR. An upregulation of these genes in GIMAP4 siRNA-treated cells compared to mock-transfected cells (but not necessarily a scrambled control) would indicate an interferon response.

Q3: How can I be sure that the observed changes in my experiment are due to GIMAP4 knockdown and not an off-target effect?

A3: This requires a series of rigorous controls. The best practice is to:

- Use multiple siRNAs: Test at least two or three different siRNAs that target different sequences of the GIMAP4 mRNA. If they all produce the same phenotype, it is more likely to be a true on-target effect.
- Perform a rescue experiment: After knocking down the endogenous GIMAP4, introduce a form of the GIMAP4 gene that is resistant to your siRNA (e.g., by making silent mutations in the siRNA target site). If this rescues the phenotype, it confirms the specificity of your siRNA.
- Use a low siRNA concentration: Titrate your GIMAP4 siRNA to the lowest possible concentration that still gives effective knockdown.[5][6] Off-target effects are often concentration-dependent.[6]
- Monitor ISGs: Always run a parallel assay (like RT-qPCR for OAS1 and IFIT1) to check for the activation of the interferon response.

Q4: What are the key pathways involved in the off-target interferon response to siRNA?

A4: The primary pathways involve pattern recognition receptors (PRRs) that detect viral nucleic acids. For siRNA, these include:

- **Toll-Like Receptors (TLRs):** TLR3, TLR7, and TLR8 are located in endosomes and can recognize dsRNA and ssRNA, leading to an interferon response. This is particularly relevant when using lipid-based transfection reagents that deliver siRNA via the endosomal pathway.
- **Cytoplasmic Sensors:** RIG-I (Retinoic acid-inducible gene I) and MDA5 (Melanoma differentiation-associated protein 5) are cytoplasmic sensors of dsRNA. Activation of these sensors leads to downstream signaling through MAVS (Mitochondrial Antiviral-Signaling protein), culminating in the production of Type I interferons.<sup>[7]</sup>

## Troubleshooting Guides

Problem 1: High expression of Interferon-Stimulated Genes (ISGs) with GIMAP4 siRNA.

Potential Cause	Recommended Solution	Explanation
High siRNA Concentration	Titrate GIMAP4 siRNA concentration down to the 1-10 nM range.	Off-target interferon activation is highly dose-dependent. Using the lowest effective concentration minimizes this response.[6]
siRNA Sequence Motifs	Test an alternative GIMAP4 siRNA with a different sequence. Use siRNA design tools that filter for potential immunostimulatory motifs.	Certain sequence motifs (e.g., GU-rich sequences) are known to be more potent activators of TLRs.
Transfection Reagent	Use a transfection reagent specifically designed for siRNA delivery (e.g., INTERFERin®). Consider alternative delivery methods like electroporation or nucleofection if problems persist.	Lipid-based reagents can deliver siRNA to endosomes, activating TLRs. Electroporation delivers siRNA directly to the cytoplasm, bypassing this route. The original GIMAP4 knockdown studies in T-cells used nucleofection.[1]
Unmodified siRNA	Use chemically modified GIMAP4 siRNA (e.g., with 2'-O-methyl modifications).	Chemical modifications, particularly at the 2' position of the ribose sugar, can help the siRNA evade recognition by PRRs without affecting its silencing activity.[8][9][10]

Problem 2: GIMAP4 siRNA is effective, but so is my "non-targeting" or "scrambled" control siRNA.

Potential Cause	Recommended Solution	Explanation
Control siRNA is Immunostimulatory	Test a different validated negative control siRNA. Ensure the control has been screened for minimal off-target and interferon effects.	Not all scrambled controls are created equal. Some sequences can inadvertently trigger an immune response.
General Transfection-Induced Stress	Include a "mock" transfection control (transfection reagent only, no siRNA).	The process of transfection itself can induce a stress response in cells. A mock control helps to isolate the effects of the siRNA molecule.
Off-target Effects of Control	Perform a BLAST search with your control siRNA sequence to ensure it doesn't have partial complementarity to other genes in your model system.	A "non-targeting" control could have unintended targets that produce a phenotype.

## Quantitative Data Summary

Table 1: Effect of GIMAP4 siRNA on IFN- $\gamma$  Secretion in Human CD4+ T cells (Data summarized from Heinonen et al., 2014)[1]

Time Point	Treatment	IFN- $\gamma$ Secretion (Relative to Control)	p-value
72 hours	GIMAP4 siRNA	Decreased	0.013
96 hours	GIMAP4 siRNA	Not Significantly Affected (mRNA level)	0.018

Table 2: Effect of siRNA Concentration on Off-Target Gene Regulation (Data summarized from Caffrey et al., 2011)[6]

siRNA Concentration	Target Silencing (STAT3)	Number of Off-Target Genes Down-regulated >2-fold	Number of Off-Target Genes Up-regulated >2-fold (Immune Response Genes)
25 nM	High	56	High
10 nM	High	30	High (but reduced)
1 nM	Moderate-High	Significantly Reduced	Significantly Reduced

## Experimental Protocols & Methodologies

Protocol 1: GIMAP4 Knockdown in Human CD4+ T Cells via Nucleofection (Adapted from Heinonen et al., 2014)[1]

- Cell Preparation: Isolate naive human CD4+ T cells from umbilical cord blood.
- siRNA Preparation: Use GIMAP4-specific siRNA (siGimap4) and a non-targeting control siRNA (siScramble).
- Nucleofection: Resuspend 5-8 million T cells in 100 µL of human T-cell nucleofector solution. Add the desired concentration of siGimap4 or siScramble. Transfer the mixture to a cuvette and use an Amaxa Nucleofector device with the appropriate program (e.g., V-024).
- Cell Culture: Immediately after nucleofection, transfer cells to pre-warmed complete RPMI medium. Allow cells to rest for 4 hours.
- T-cell Activation & Differentiation: Activate cells with anti-CD3/anti-CD28 beads and induce Th1 differentiation with IL-12.
- Analysis:
  - Gene Knockdown Verification: At 48-72 hours post-transfection, harvest a portion of the cells, extract RNA, and perform RT-qPCR to measure GIMAP4 mRNA levels.

- IFN- $\gamma$  Secretion: Collect cell culture supernatant at 24, 48, and 72 hours. Measure the concentration of secreted IFN- $\gamma$  using an ELISA kit.
- Interferon Response Check: Use a portion of the RNA from the knockdown verification step to measure the expression of ISGs (e.g., OAS1, IFIT1) to monitor for off-target effects.

#### Protocol 2: Quantification of Interferon-Stimulated Gene (ISG) Expression

- Experimental Setup: Include the following conditions:
  - Untreated cells
  - Mock transfected (transfection reagent only)
  - Scrambled control siRNA
  - GIMAP4 siRNA
- RNA Extraction: At 24 hours post-transfection, harvest cells and extract total RNA using a standard kit (e.g., RNeasy).
- cDNA Synthesis: Synthesize cDNA from 1  $\mu$ g of total RNA using a reverse transcription kit.
- RT-qPCR: Perform quantitative real-time PCR using SYBR Green or TaqMan probes for your target ISGs (e.g., OAS1, IFIT1, STAT1) and a housekeeping gene (e.g., GAPDH, ACTB) for normalization.
- Data Analysis: Calculate the fold change in ISG expression for each condition relative to the mock-transfected control using the  $\Delta\Delta$ Ct method. A significant increase in ISG expression in the siRNA-treated wells indicates an off-target interferon response.

## Signaling Pathways and Workflow Diagrams

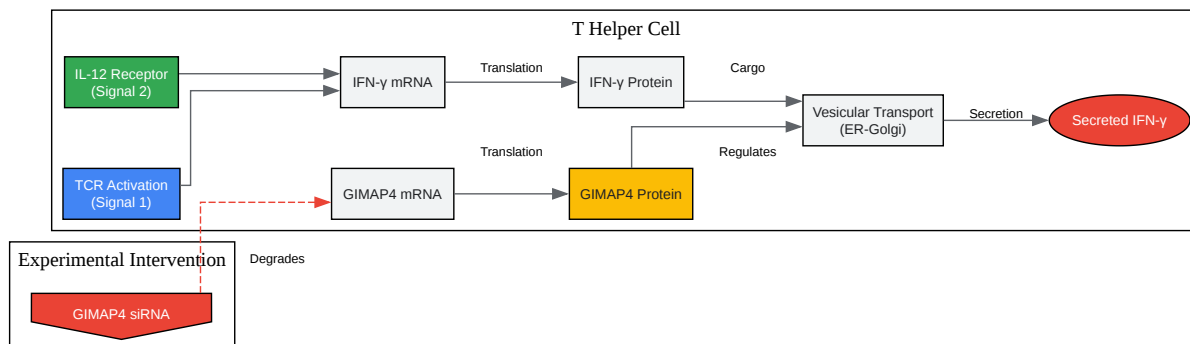

[Click to download full resolution via product page](#)

Caption: GIMAP4's role in the IFN- $\gamma$  secretion pathway.

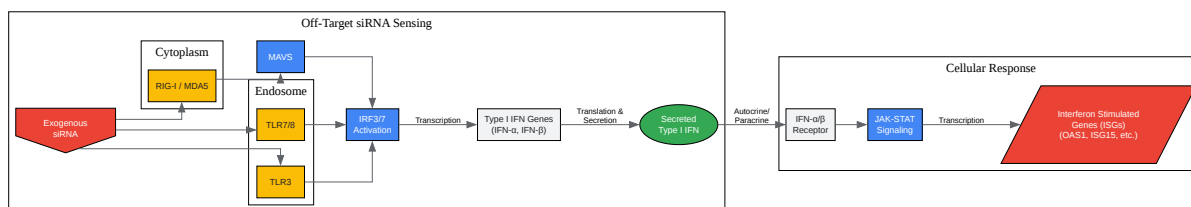

[Click to download full resolution via product page](#)

Caption: Off-target activation of Type I interferon by siRNA.

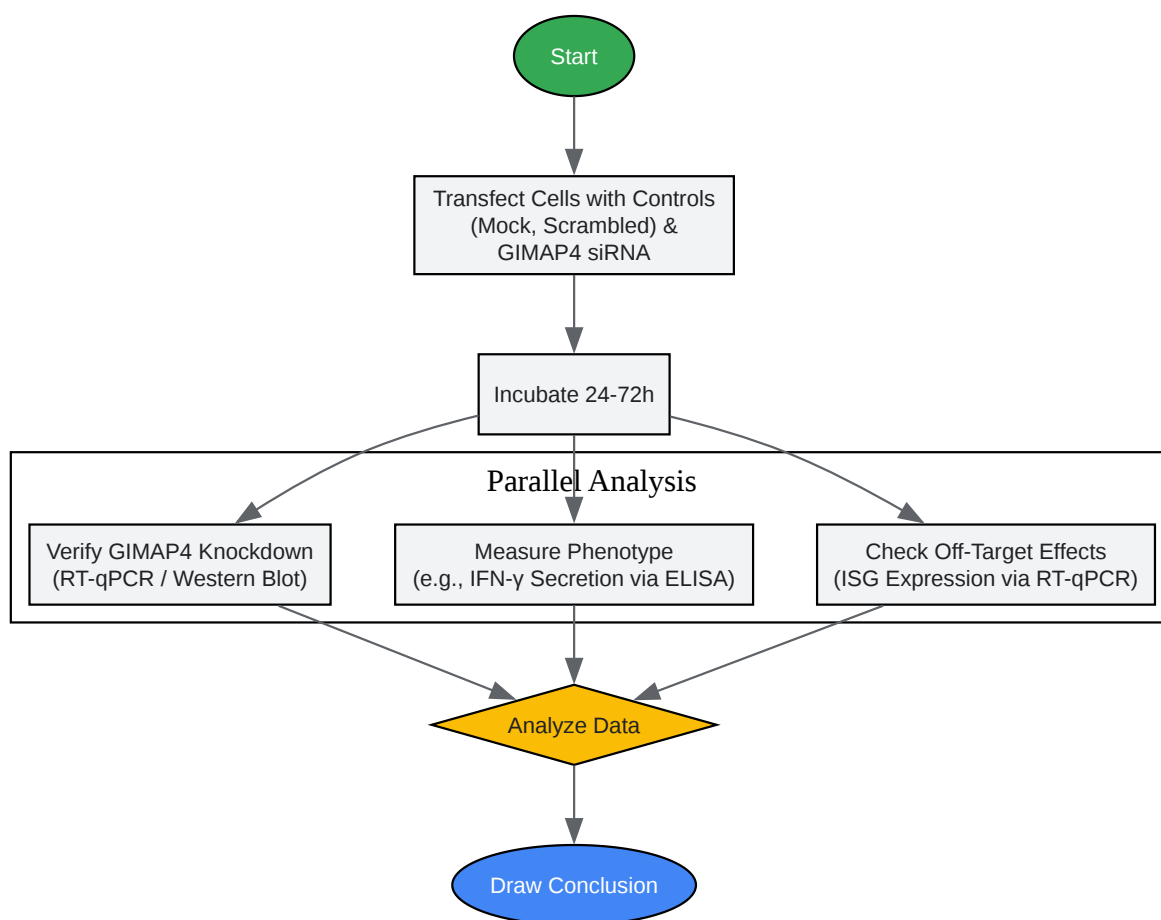

[Click to download full resolution via product page](#)

Caption: Recommended workflow for a GIMAP4 siRNA experiment.

### Need Custom Synthesis?

BenchChem offers custom synthesis for rare earth carbides and specific isotopic labeling.

Email: [info@benchchem.com](mailto:info@benchchem.com) or [Request Quote Online](#).

## References

- 1. Tubulin- and actin-associating GIMAP4 is required for IFN- $\gamma$  secretion during Th cell differentiation - PMC [[pmc.ncbi.nlm.nih.gov](https://pubmed.ncbi.nlm.nih.gov/)]
- 2. Tubulin- and actin-associating GIMAP4 is required for IFN- $\gamma$  secretion during Th cell differentiation - PubMed [[pubmed.ncbi.nlm.nih.gov](https://pubmed.ncbi.nlm.nih.gov/)]
- 3. [pblsaysci.com](https://pblsaysci.com/) [[pblsaysci.com](https://pblsaysci.com/)]
- 4. [researchgate.net](https://researchgate.net/) [[researchgate.net](https://researchgate.net/)]
- 5. Guidelines for transfection of siRNA [[qiagen.com](https://qiagen.com/)]
- 6. siRNA Off-Target Effects Can Be Reduced at Concentrations That Match Their Individual Potency | PLOS One [[journals.plos.org](https://journals.plos.org/)]
- 7. Treatment with siRNAs is commonly associated with GPX4 up-regulation and target knockdown-independent sensitization to ferroptosis - PMC [[pmc.ncbi.nlm.nih.gov](https://pubmed.ncbi.nlm.nih.gov/)]
- 8. Chemical modifications on siRNAs avoid Toll-like-receptor-mediated activation of the hepatic immune system in vivo and in vitro - PubMed [[pubmed.ncbi.nlm.nih.gov](https://pubmed.ncbi.nlm.nih.gov/)]
- 9. The Impact of Chemical Modifications on the Interferon-Inducing and Antiproliferative Activity of Short Double-Stranded Immunostimulating RNA - PMC [[pmc.ncbi.nlm.nih.gov](https://pubmed.ncbi.nlm.nih.gov/)]
- 10. Position-specific chemical modification of siRNAs reduces “off-target” transcript silencing - PMC [[pmc.ncbi.nlm.nih.gov](https://pubmed.ncbi.nlm.nih.gov/)]
- To cite this document: BenchChem. [Avoiding interferon response with GIMAP4 siRNA]. BenchChem, [2026]. [Online PDF]. Available at: [<https://www.benchchem.com/product/b15573996/docs#avoiding-interferon-response-with-gimap4-sirna>]

---

### Disclaimer & Data Validity:

The information provided in this document is for Research Use Only (RUO) and is strictly not intended for diagnostic or therapeutic procedures. While BenchChem strives to provide accurate protocols, we make no warranties, express or implied, regarding the fitness of this product for every specific experimental setup.

**Technical Support:** The protocols provided are for reference purposes. Unsure if this reagent suits your experiment?

**Need Industrial/Bulk Grade?** [Request Custom Synthesis Quote](#)

# BenchChem

Our mission is to be the trusted global source of essential and advanced chemicals, empowering scientists and researchers to drive progress in science and industry.

## Contact

Address: 3281 E Guasti Rd

Ontario, CA 91761, United States

Phone: (601) 213-4426

Email: [info@benchchem.com](mailto:info@benchchem.com)

[Contact our Ph.D. Support Team for a compatibility check](#)