

GNE-272 Off-Target Effects Investigation: A Technical Support Resource

Author: BenchChem Technical Support Team. **Date:** April 2026

Compound of Interest

Compound Name: GNE-272

Cat. No.: B15572429

[Get Quote](#)

This technical support center provides researchers, scientists, and drug development professionals with essential information for investigating the off-target effects of **GNE-272**, a potent and selective inhibitor of the CBP/EP300 bromodomains. This guide includes troubleshooting advice, frequently asked questions, detailed experimental protocols, and a summary of known off-target interaction data.

Troubleshooting Guides and FAQs

This section addresses specific issues that may arise during experiments with **GNE-272**.

Frequently Asked Questions (FAQs)

- Q1: What are the primary known on-targets of **GNE-272**? A1: **GNE-272** is a potent and selective inhibitor of the bromodomains of the closely related transcriptional co-activators CREB-binding protein (CBP) and E1A binding protein p300 (EP300).[1]
- Q2: What is the most significant known off-target of **GNE-272**? A2: The most significant known off-target is the bromodomain of BRD4. However, **GNE-272** is remarkably selective for CBP/EP300 over BRD4, with a selectivity margin of approximately 650-fold.[1]

- Q3: Has **GNE-272** been screened against a broader panel of potential off-targets? A3: Yes, **GNE-272** was tested at a concentration of 10 μ M against a panel of 35 kinases and 42 receptors. In this screening, it did not show significant inhibition (less than 30%) of any of these targets.[1] Additionally, it did not inhibit several cytochrome P450 enzymes (3A4, 1A2, 2C9, 2C19, 2D6) at concentrations up to 10 μ M.[1]
- Q4: What are the downstream cellular effects of **GNE-272** on its on-targets? A4: By inhibiting CBP/EP300, **GNE-272** can modulate the expression of genes regulated by these co-activators. A key downstream effect is the inhibition of MYC expression.[1] **GNE-272** has also been shown to downregulate the expression of SNAI2.

Troubleshooting

- Issue 1: Weaker than expected downregulation of MYC expression in our cell line.
 - Possible Cause 1: Cell line dependency. The regulation of MYC can be complex and vary between different cell lines. Some cell lines may have alternative pathways that compensate for the inhibition of CBP/EP300.
 - Troubleshooting Step 1: Confirm target engagement in your specific cell line using an orthogonal assay, such as a cellular thermal shift assay (CETSA) or a BRET cellular assay.
 - Possible Cause 2: Suboptimal **GNE-272** concentration or treatment duration. The effective concentration and time required to observe downstream effects can vary.
 - Troubleshooting Step 2: Perform a dose-response and time-course experiment to determine the optimal conditions for your experimental system.
 - Possible Cause 3: Experimental variability. Inconsistent cell densities, passage numbers, or reagent quality can lead to variable results.
 - Troubleshooting Step 3: Standardize your cell culture and experimental procedures. Ensure all reagents are of high quality and have not expired.
- Issue 2: Observed cytotoxicity in a cell line that is not correlated with MYC downregulation.

- Possible Cause 1: Off-target effects. While **GNE-272** is highly selective, at higher concentrations or in specific cellular contexts, off-target activities could contribute to cytotoxicity.
- Troubleshooting Step 1: Review the off-target screening data to see if any of the weakly inhibited targets are particularly relevant to your cell line's biology. Consider performing a broader unbiased screen, such as a kinome scan, at the concentration where you observe cytotoxicity.
- Possible Cause 2: On-target effects independent of MYC. CBP/EP300 regulate numerous transcription factors and signaling pathways beyond MYC. The observed cytotoxicity may be an on-target effect that is not mediated by MYC in your specific cellular context.
- Troubleshooting Step 2: Investigate the effect of **GNE-272** on other known CBP/EP300-regulated pathways, such as those involving p53, NF- κ B, or TGF- β /SMAD.

Data Presentation

Table 1: In Vitro Potency and Selectivity of **GNE-272**

Target	Assay Type	IC50 / EC50 (μ M)
CBP	TR-FRET	0.02
EP300	TR-FRET	0.03
BRD4	TR-FRET	13
MYC Expression (MV4-11 cells)	Cellular Assay	0.91

Table 2: **GNE-272** Off-Target Screening Summary

Target Class	Number of Targets	GNE-272 Concentration (μM)	Result
Kinases	35	10	No target inhibited by >30%
Receptors	42	10	No target inhibited by >30%
Cytochrome P450s	5 (3A4, 1A2, 2C9, 2C19, 2D6)	>10	No inhibition observed

Experimental Protocols

1. Time-Resolved Fluorescence Resonance Energy Transfer (TR-FRET) Assay for CBP/EP300 Inhibition

This protocol is a generalized procedure based on standard TR-FRET principles for assessing the binding of **GNE-272** to the bromodomains of CBP and EP300.

- Principle: This assay measures the disruption of the interaction between a biotinylated histone peptide (e.g., H3K27ac) and a GST-tagged bromodomain protein. A Europium-labeled anti-GST antibody serves as the donor fluorophore, and streptavidin-conjugated Allophycocyanin (APC) is the acceptor. When the bromodomain and peptide are in close proximity, FRET occurs. **GNE-272** competes with the histone peptide for binding to the bromodomain, leading to a decrease in the FRET signal.
- Materials:
 - GST-tagged CBP or EP300 bromodomain protein
 - Biotinylated histone H3K27ac peptide
 - Europium-labeled anti-GST antibody
 - Streptavidin-APC
 - **GNE-272**

- Assay buffer (e.g., 50 mM HEPES, pH 7.5, 100 mM NaCl, 0.1% BSA, 0.05% Tween-20)
- 384-well low-volume microplates
- TR-FRET compatible plate reader
- Procedure:
 - Prepare serial dilutions of **GNE-272** in assay buffer.
 - In a 384-well plate, add the **GNE-272** dilutions.
 - Add the GST-tagged bromodomain protein and the biotinylated histone peptide to the wells.
 - Incubate for 15 minutes at room temperature.
 - Add the Europium-labeled anti-GST antibody and streptavidin-APC mixture.
 - Incubate for 1 hour at room temperature, protected from light.
 - Read the plate on a TR-FRET plate reader, measuring the emission at both the donor and acceptor wavelengths (e.g., 615 nm for Europium and 665 nm for APC).
 - Calculate the TR-FRET ratio (Acceptor emission / Donor emission) and plot the results against the **GNE-272** concentration to determine the IC50 value.

2. Bioluminescence Resonance Energy Transfer (BRET) Cellular Assay for Target Engagement

This protocol is a generalized procedure to measure the engagement of **GNE-272** with its target in living cells.

- Principle: This assay measures the proximity of a NanoLuc luciferase-tagged bromodomain protein and a HaloTag-fused histone H3.3. In the presence of a cell-permeable fluorescent HaloTag ligand, energy transfer occurs from the luciferase to the fluorophore when the two fusion proteins are in close proximity. **GNE-272** enters the cell and disrupts this interaction, leading to a decrease in the BRET signal.

- Materials:
 - Cells (e.g., HEK293) co-transfected with plasmids encoding NanoLuc-CBP/EP300 bromodomain and HaloTag-Histone H3.3
 - **GNE-272**
 - Nano-Glo® Live Cell Reagent (or similar luciferase substrate)
 - HaloTag® NanoBRET™ 618 Ligand (or similar fluorescent ligand)
 - Opti-MEM® or other serum-free medium
 - White, opaque 96-well or 384-well microplates
 - BRET-compatible plate reader
- Procedure:
 - Seed the co-transfected cells into a white, opaque microplate and allow them to attach overnight.
 - Prepare serial dilutions of **GNE-272** in Opti-MEM®.
 - Add the HaloTag® NanoBRET™ 618 Ligand to the **GNE-272** dilutions.
 - Remove the culture medium from the cells and add the **GNE-272**/HaloTag ligand mixture.
 - Incubate for the desired time (e.g., 2 hours) at 37°C.
 - Add the Nano-Glo® Live Cell Reagent to each well.
 - Incubate for 3-5 minutes at room temperature.
 - Read the plate on a BRET plate reader, measuring the luminescence at both the donor and acceptor wavelengths (e.g., 460 nm for NanoLuc and >600 nm for the HaloTag ligand).

- Calculate the BRET ratio and plot against the **GNE-272** concentration to determine the EC50 value.

Mandatory Visualizations

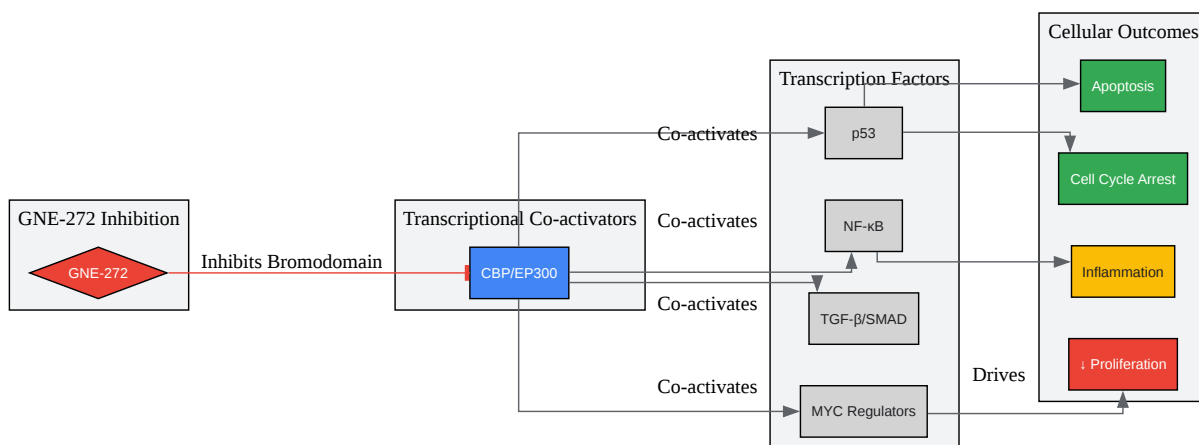

[Click to download full resolution via product page](#)

Caption: On-target signaling pathway of **GNE-272**.

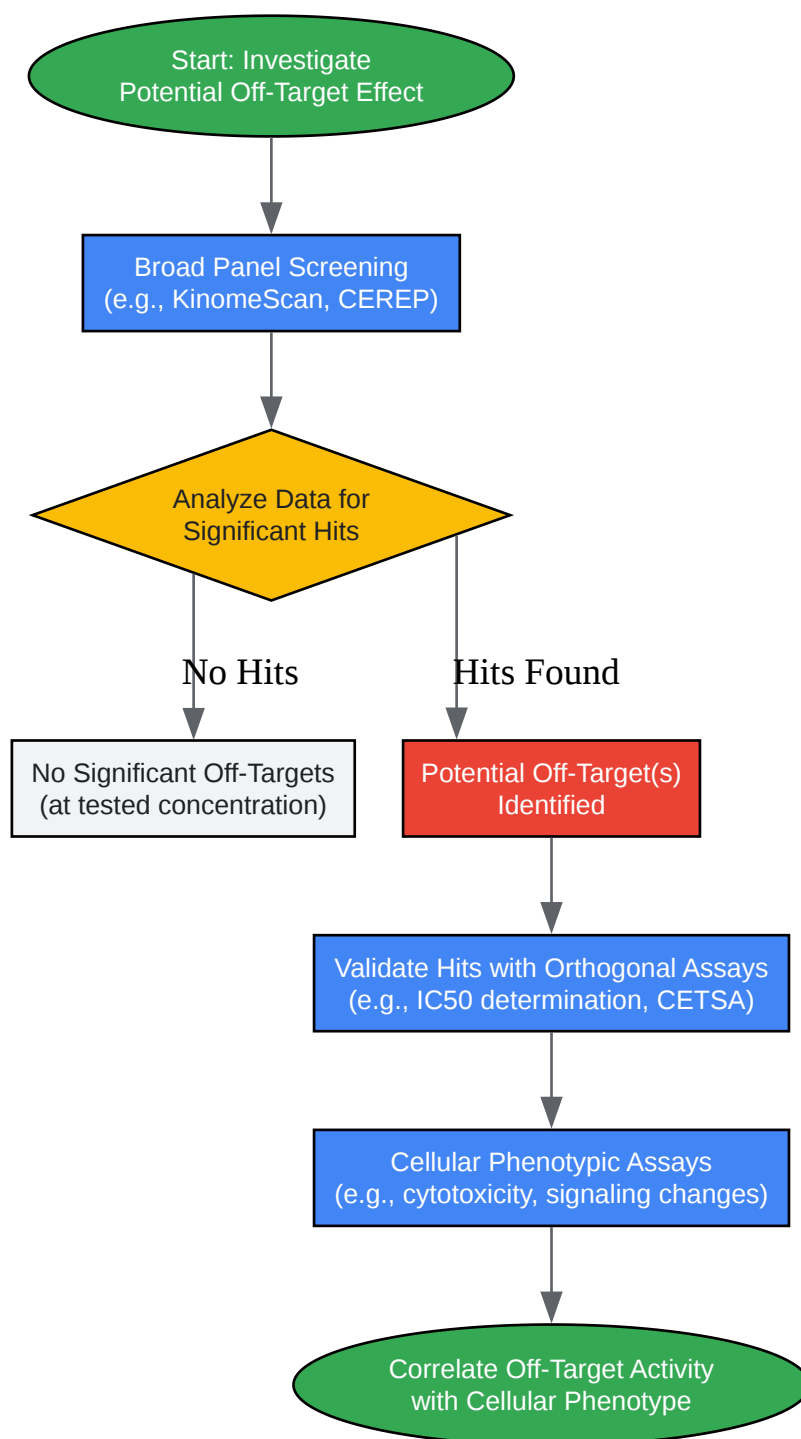

[Click to download full resolution via product page](#)

Caption: Experimental workflow for off-target investigation.

Need Custom Synthesis?

BenchChem offers custom synthesis for rare earth carbides and specific isotopic labeling.

Email: info@benchchem.com or [Request Quote Online](#).

References

- [1. Targeting CBP and p300: Emerging Anticancer Agents - PMC \[pmc.ncbi.nlm.nih.gov\]](#)
- To cite this document: BenchChem. [GNE-272 Off-Target Effects Investigation: A Technical Support Resource]. BenchChem, [2026]. [Online PDF]. Available at: [\[https://www.benchchem.com/product/b15572429/docs#gne-272-off-target-effects-investigation-a-technical-support-resource\]](https://www.benchchem.com/product/b15572429/docs#gne-272-off-target-effects-investigation-a-technical-support-resource)

Disclaimer & Data Validity:

The information provided in this document is for Research Use Only (RUO) and is strictly not intended for diagnostic or therapeutic procedures. While BenchChem strives to provide accurate protocols, we make no warranties, express or implied, regarding the fitness of this product for every specific experimental setup.

Technical Support: The protocols provided are for reference purposes. Unsure if this reagent suits your experiment?

Need Industrial/Bulk Grade? [Request Custom Synthesis Quote](#)

BenchChem

Our mission is to be the trusted global source of essential and advanced chemicals, empowering scientists and researchers to drive progress in science and industry.

Contact

Address: 3281 E Guasti Rd

Ontario, CA 91761, United States

Phone: (601) 213-4426

Email: info@benchchem.com

Contact our Ph.D. Support Team for a compatibility check