

# Application Notes and Protocols for Soquelitinib in In Vitro T-Cell Assays

**Author:** BenchChem Technical Support Team. **Date:** December 2025

## Compound of Interest

Compound Name: Socrodeucitinib

Cat. No.: B15572926

[Get Quote](#)

For Researchers, Scientists, and Drug Development Professionals

These application notes provide detailed protocols for utilizing Soquelitinib, a selective and covalent inhibitor of Interleukin-2-inducible T-cell kinase (ITK), in various in vitro T-cell assays. The provided methodologies are designed to enable the investigation of Soquelitinib's effects on T-cell signaling, proliferation, and cytokine production.

Soquelitinib is an investigational small molecule that functions by selectively targeting ITK, a key enzyme in the T-cell receptor (TCR) signaling pathway.<sup>[1][2][3][4]</sup> This inhibition leads to a "Th1 skewing" of the immune response, characterized by the suppression of Th2 and Th17 helper T-cell functions while promoting Th1-type immunity.<sup>[1][2][4]</sup> This mechanism of action suggests its potential therapeutic utility in T-cell mediated diseases, including certain cancers and inflammatory conditions.<sup>[1][2]</sup>

## Data Presentation: In Vitro Activity of Soquelitinib

The following tables summarize the quantitative data regarding the in vitro activity of Soquelitinib across various T-cell functional assays.

Assay	Cell Type	Stimulation	Key Parameter	Result
T-Cell Proliferation	Human T-cells	TCR stimulation	Inhibition	Dose-dependent reduction in proliferation.
Cytokine Production	Human CD4+ T-cells	TCR stimulation	IC50 (IL-2 secretion)	~136 nM in Jurkat cells.[5]
Human CD4+ T-cells	ImmunoCult™ Human CD3/CD28 T Cell Activator	Th2 Cytokine Inhibition	Significant reduction of IL-4, IL-5, and IL-13. [1]	
Human CD4+ T-cells	ImmunoCult™ Human CD3/CD28 T Cell Activator	Th1 Cytokine Production	Relative sparing of IFN $\gamma$ production.[5][6]	
Naïve Human CD4+ T-cells	Th17 polarizing conditions	Th17 Cytokine Inhibition	Dose-dependent reduction of IL-17.	
Signaling	H9 cells	anti-CD3	pPLCy1 Inhibition	Dose-dependent inhibition.
H9 cells	anti-CD3	pZAP-70 Inhibition	Dose-dependent inhibition.	
Human T-cells	anti-CD3/CD28 crosslinking	pERK Inhibition	Dose-dependent inhibition.[6]	
Human T-cells	anti-CD3/CD28 crosslinking	pS6 Inhibition	Dose-dependent inhibition.[6]	
T-Cell Differentiation	Naïve Human CD4+ T-cells	Th17 polarizing conditions	Th17 Differentiation	Dose-dependent inhibition.[7]
Naïve Human CD4+ T-cells	Th17 polarizing conditions	Treg Differentiation	Increase in Foxp3+ Treg cells.[7]	

## Experimental Protocols

### T-Cell Proliferation Assay

This protocol outlines the steps to assess the effect of Soquelitinib on T-cell proliferation following TCR stimulation.

#### Materials:

- Human Peripheral Blood Mononuclear Cells (PBMCs)
- Soquelitinib (various concentrations)
- RPMI-1640 medium supplemented with 10% FBS, 1% Penicillin-Streptomycin, and 2 mM L-glutamine
- 96-well flat-bottom plates
- Plate-bound anti-CD3 antibody (clone OKT3) and soluble anti-CD28 antibody (clone CD28.2)
- Proliferation assay reagent (e.g., CellTiter-Glo® Luminescent Cell Viability Assay or similar)
- Luminometer

#### Methodology:

- **Plate Coating:** Coat a 96-well plate with anti-CD3 antibody at a concentration of 1-5 µg/mL in sterile PBS overnight at 4°C.
- **Cell Preparation:** Isolate PBMCs from healthy donor blood using Ficoll-Paque density gradient centrifugation. Resuspend cells in complete RPMI-1640 medium.
- **Assay Setup:** a. Wash the coated plate twice with sterile PBS to remove unbound antibody. b. Seed the PBMCs at a density of  $1 \times 10^5$  cells/well in 100 µL of complete medium. c. Prepare serial dilutions of Soquelitinib in complete medium. d. Add 50 µL of the Soquelitinib dilutions to the respective wells. Include a DMSO vehicle control. e. Add 50 µL of soluble

anti-CD28 antibody to a final concentration of 1-2 µg/mL to all wells except for the unstimulated control.

- Incubation: Incubate the plate for 72 hours at 37°C in a humidified 5% CO<sub>2</sub> incubator.
- Readout: Measure cell proliferation according to the manufacturer's instructions for the chosen proliferation assay reagent.

## Cytokine Production Assay

This protocol is designed to measure the effect of Soquelitinib on the production of key Th1, Th2, and Th17 cytokines by stimulated T-cells.

Materials:

- Isolated human CD4<sup>+</sup> T-cells
- Soquelitinib (various concentrations)
- Complete RPMI-1640 medium
- 96-well U-bottom plates
- ImmunoCult™ Human CD3/CD28 T Cell Activator
- Cytokine measurement kit (e.g., ELISA or multiplex bead-based assay for IFN $\gamma$ , IL-4, IL-5, IL-13, IL-17)
- Plate reader or flow cytometer

Methodology:

- Cell Preparation: Isolate CD4<sup>+</sup> T-cells from PBMCs using a negative selection kit. Resuspend cells in complete RPMI-1640 medium.
- Assay Setup: a. Seed the CD4<sup>+</sup> T-cells at a density of  $2 \times 10^5$  cells/well in 100 µL of complete medium in a 96-well U-bottom plate. b. Pre-treat the cells with various concentrations of Soquelitinib or DMSO vehicle control for 1 hour at 37°C.[6] c. Add

ImmunoCult™ Human CD3/CD28 T Cell Activator according to the manufacturer's instructions.

- Incubation: Incubate the plate for 48-72 hours at 37°C in a humidified 5% CO<sub>2</sub> incubator.[6]
- Supernatant Collection: Centrifuge the plate and carefully collect the cell culture supernatants.
- Cytokine Measurement: Quantify the concentration of IFN $\gamma$ , IL-4, IL-5, IL-13, and IL-17 in the supernatants using an appropriate cytokine measurement kit.

## Western Blot for T-Cell Signaling Pathway Analysis

This protocol details the analysis of key phosphorylation events in the TCR signaling cascade following Soquelitinib treatment.

Materials:

- Jurkat T-cells or isolated human T-cells
- Soquelitinib (various concentrations)
- Serum-free RPMI-1640 medium
- Anti-CD3 antibody (clone OKT3)
- Goat anti-mouse IgG for crosslinking
- Lysis buffer (e.g., RIPA buffer) with protease and phosphatase inhibitors
- Primary antibodies: anti-phospho-PLC $\gamma$ 1, anti-PLC $\gamma$ 1, anti-phospho-ZAP-70, anti-ZAP-70, anti-phospho-ERK, anti-ERK
- HRP-conjugated secondary antibodies
- Chemiluminescent substrate
- Western blotting equipment and reagents

### Methodology:

- **Cell Culture and Treatment:** a. Culture Jurkat T-cells in complete RPMI-1640 medium. b. Starve the cells in serum-free medium for 2-4 hours prior to the experiment. c. Pre-treat the cells with various concentrations of Soquelitinib or DMSO vehicle control for 1 hour at 37°C.
- **T-Cell Stimulation:** a. Stimulate the cells with soluble anti-CD3 antibody (1-2 µg/mL) for 5-10 minutes at 37°C. b. For enhanced signaling, crosslink the anti-CD3 antibody with goat anti-mouse IgG.
- **Cell Lysis:** a. Pellet the cells by centrifugation and wash with ice-cold PBS. b. Lyse the cells in ice-cold lysis buffer. c. Clarify the lysates by centrifugation and collect the supernatants.
- **Western Blotting:** a. Determine the protein concentration of the lysates. b. Separate equal amounts of protein by SDS-PAGE and transfer to a PVDF membrane. c. Block the membrane and probe with the indicated primary antibodies overnight at 4°C. d. Wash the membrane and incubate with the appropriate HRP-conjugated secondary antibody. e. Visualize the protein bands using a chemiluminescent substrate and an imaging system.

## Visualizations

Soquelitinib Mechanism of Action in T-Cell Signaling

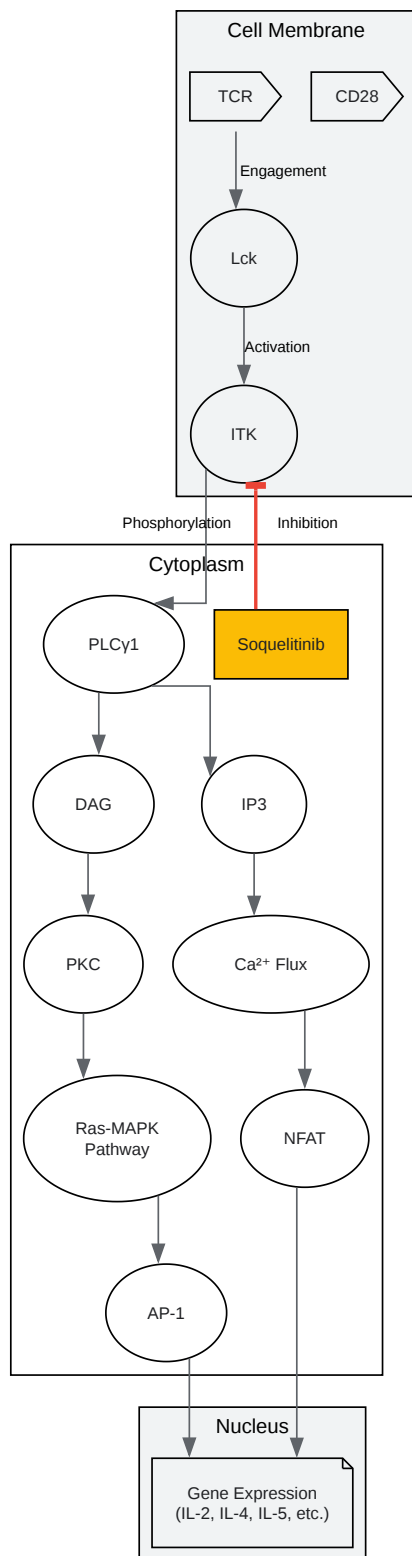

[Click to download full resolution via product page](#)

Caption: Soquelitinib inhibits ITK, a key kinase downstream of the T-cell receptor.

General Workflow for In Vitro T-Cell Assays with Soquelitinib

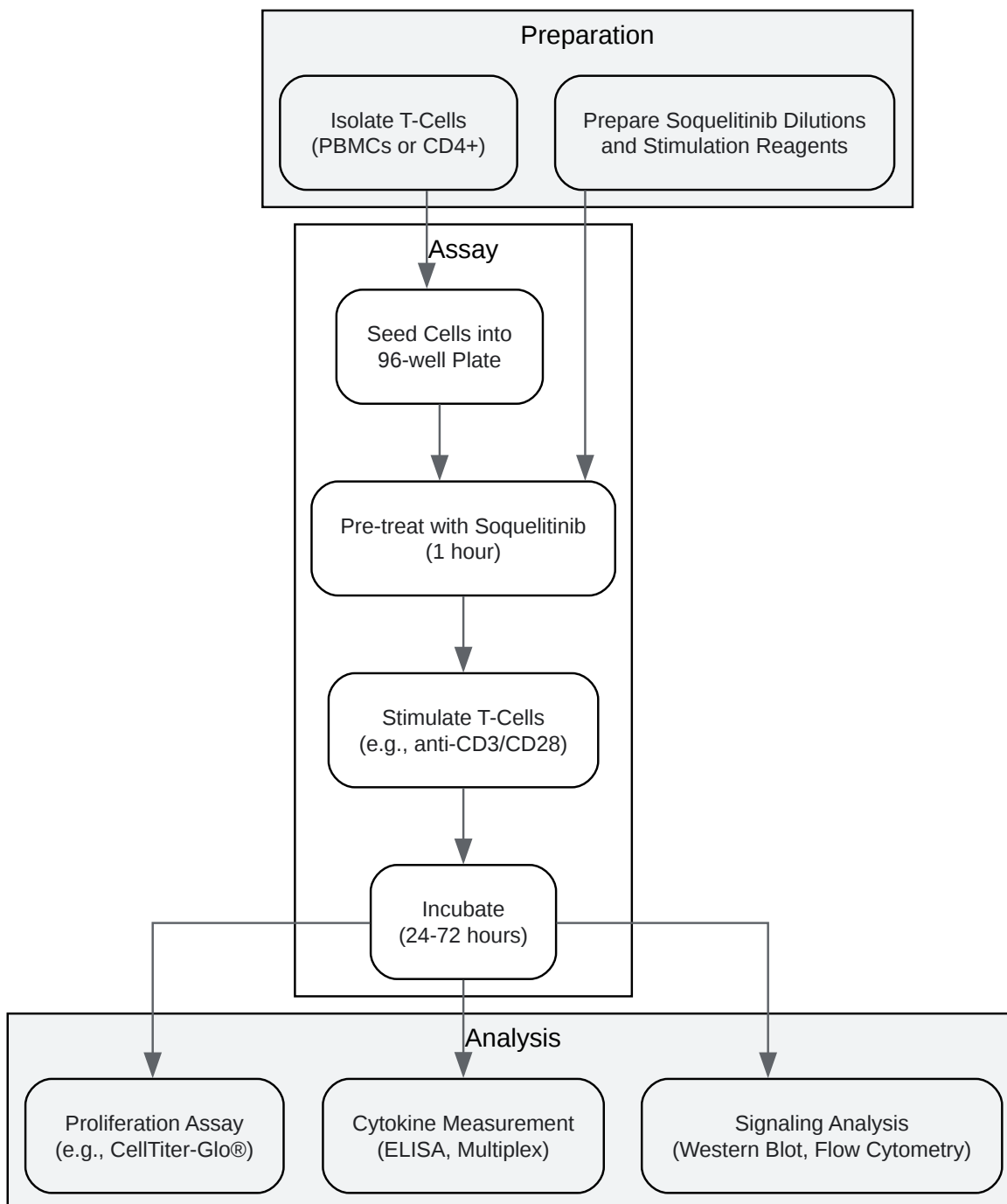

[Click to download full resolution via product page](#)

Caption: A generalized workflow for studying Soquelitinib's effects on T-cells in vitro.



**Need Custom Synthesis?**

BenchChem offers custom synthesis for rare earth carbides and specific isotopic labeling.

Email: [info@benchchem.com](mailto:info@benchchem.com) or [Request Quote Online](#).

## References

- 1. Corvus Pharmaceuticals Announces Publication of Preclinical Data Demonstrating Potential of ITK Inhibition with Soquelitinib as a Novel Approach to T Cell-Mediated Inflammatory and Immune Diseases - BioSpace [biospace.com]
- 2. Corvus Pharmaceuticals Initiates Registrational Phase 3 Clinical Trial of Soquelitinib for Patients with Relapsed/Refractory Peripheral T-Cell Lymphoma | Corvus Pharmaceuticals [corvuspharma.gcs-web.com]
- 3. onclive.com [onclive.com]
- 4. Corvus Pharmaceuticals Announces Publication of Preclinical Data Demonstrating Potential Novel Approach to Immunotherapy Based on Inhibition of ITK with Soquelitinib (CPI-818) | Corvus Pharmaceuticals [investor.corvuspharma.com]
- 5. biorxiv.org [biorxiv.org]
- 6. researchgate.net [researchgate.net]
- 7. Publication of Preclinical Data in Science Signaling Demonstrated the Potential of ITK Inhibition with Soquelitinib as a Novel Approach to Treatment of Inflammatory Diseases - BioSpace [biospace.com]
- To cite this document: BenchChem. [Application Notes and Protocols for Soquelitinib in In Vitro T-Cell Assays]. BenchChem, [2025]. [Online PDF]. Available at: [https://www.benchchem.com/product/b15572926#protocol-for-using-soquelitinib-in-in-vitro-t-cell-assays]

---

**Disclaimer & Data Validity:**

The information provided in this document is for Research Use Only (RUO) and is strictly not intended for diagnostic or therapeutic procedures. While BenchChem strives to provide accurate protocols, we make no warranties, express or implied, regarding the fitness of this product for every specific experimental setup.

**Technical Support:** The protocols provided are for reference purposes. Unsure if this reagent suits your experiment? [[Contact our Ph.D. Support Team for a compatibility check](#)]

**Need Industrial/Bulk Grade?** [Request Custom Synthesis Quote](#)

## BenchChem

Our mission is to be the trusted global source of essential and advanced chemicals, empowering scientists and researchers to drive progress in science and industry.

### Contact

Address: 3281 E Guasti Rd

Ontario, CA 91761, United States

Phone: (601) 213-4426

Email: [info@benchchem.com](mailto:info@benchchem.com)