

A Researcher's Guide to Control Experiments for Arachidonic Acid-Alkyne Labeling

Author: BenchChem Technical Support Team. **Date:** December 2025

Compound of Interest

Compound Name: Arachidonic acid-alkyne

Cat. No.: B15572622

[Get Quote](#)

For researchers, scientists, and drug development professionals utilizing **arachidonic acid-alkyne** (AA-alkyne) metabolic labeling, establishing rigorous control experiments is paramount for the generation of reliable and unambiguous data. This guide provides a comprehensive comparison of essential control experiments, alternative labeling methods, and detailed protocols to ensure the specificity and validity of your findings.

Arachidonic acid-alkyne is a powerful chemical tool for tracing the metabolic fate of this crucial polyunsaturated fatty acid. The terminal alkyne group allows for the covalent attachment of reporter tags, such as fluorophores or biotin, via copper(I)-catalyzed azide-alkyne cycloaddition (CuAAC), commonly known as click chemistry. This enables the visualization and enrichment of AA-containing lipids and proteins. However, the introduction of the alkyne group can potentially alter the biochemical behavior of the molecule compared to its native counterpart. Therefore, a suite of control experiments is not just recommended but essential for accurate data interpretation.

Comparison of Control Strategies and Alternative Methods

To ensure that the observed signals are a true representation of arachidonic acid metabolism and not artifacts of the labeling procedure, a multi-faceted approach to controls is necessary. The following table summarizes key control experiments and compares AA-alkyne labeling with a common alternative, stable isotope labeling.

Control/Method	Purpose	Advantages	Limitations	Expected Outcome for Valid AA-Alkyne Labeling
Negative Control: No-Labeling	To assess background signal from click chemistry reagents.	Simple to perform.	Does not control for non-specific uptake or binding of the alkyne probe.	Minimal to no signal detected in the absence of AA-alkyne incubation.
Negative Control: Vehicle	To control for effects of the delivery vehicle (e.g., BSA, DMSO, ethanol).	Accounts for any cellular response to the solvent or carrier.	Does not address specificity of the alkyne probe.	No significant difference in baseline signal compared to untreated cells.
Negative Control: Non-Alkyne Arachidonic Acid Analog	To confirm that the signal is dependent on the alkyne group for click chemistry.	Provides a direct assessment of the alkyne's role in signal generation.	Synthesis of a suitable analog may be required.	No or significantly reduced signal compared to AA-alkyne labeled samples.
Positive Control: Competition with Excess Arachidonic Acid	To demonstrate that AA-alkyne utilizes the same metabolic pathways as native AA.	Provides strong evidence for on-target metabolic incorporation.	High concentrations of competing AA may have independent biological effects.	A dose-dependent decrease in AA-alkyne signal with increasing concentrations of unlabeled AA.

Alternative Method: Stable Isotope Labeling (e.g., Deuterated AA)	To trace AA metabolism using a minimally perturbing label.	Deuterium is less likely to alter the biological activity of AA. ^{[1][2]}	Requires sensitive mass spectrometry for detection and can be more expensive.	Similar metabolic profiles and incorporation patterns to AA-alkyne, though quantitative differences may exist.
---	--	--	---	--

Quantitative Comparison: AA-Alkyne vs. Native Arachidonic Acid

Several studies have highlighted that while AA-alkyne is a valuable tool, its metabolism does not perfectly mirror that of arachidonic acid. Researchers should be aware of these differences when interpreting their results.

Parameter	Finding	Implication	Reference
Cellular Uptake	Jurkat cell uptake of arachidonic acid was 2-fold greater than that of AA-alkyne.	Cellular uptake kinetics of the alkyne analog differ from the native fatty acid.	[3]
Metabolic Elongation	Significantly more AA-alkyne was elongated to 22:4-alkyne compared to the elongation of AA to 22:4.	The alkyne modification may alter substrate preference for elongase enzymes.	[3]
Enzymatic Conversion (Platelets)	Platelets stimulated in the presence of AA-alkyne synthesized significantly less 12-lipoxygenase (12-LOX) and cyclooxygenase (COX) products than in the presence of AA.	The alkyne group can impact the efficiency of key enzymes in the eicosanoid pathway.	[3]
Enzymatic Conversion (Neutrophils)	Ionophore-stimulated neutrophils produced significantly more 5-LOX products in the presence of AA-alkyne than AA.	The effect of the alkyne group on enzyme activity can be cell-type and enzyme-specific.	[3]

Experimental Protocols

Below are detailed protocols for key control experiments.

Protocol 1: No-Labeling Control

Objective: To determine the background signal generated by the click chemistry reagents in the absence of the alkyne-labeled arachidonic acid.

Methodology:

- Culture cells to the desired confluency under standard conditions.
- Proceed with the experimental workflow, but omit the step of incubating the cells with **Arachidonic acid-alkyne**.
- Lyse the cells and perform the click chemistry reaction on the cell lysate using the same concentrations of azide-reporter (e.g., azide-fluorophore or azide-biotin), copper(I) catalyst, and reducing agent as the experimental samples.
- Analyze the samples using the same detection method (e.g., fluorescence microscopy, in-gel fluorescence, or streptavidin blotting) as the experimental samples.
- Expected Result: A minimal to negligible signal should be detected, establishing the baseline for non-specific binding of the detection reagents.

Protocol 2: Vehicle Control

Objective: To assess any non-specific effects of the vehicle used to deliver **Arachidonic acid-alkyne** to the cells.

Methodology:

- Culture cells to the desired confluency.
- Prepare a mock treatment solution containing the vehicle (e.g., fatty acid-free BSA, ethanol, or DMSO) at the same final concentration used to deliver the AA-alkyne in the experimental samples.
- Incubate the cells with the vehicle control solution for the same duration as the AA-alkyne treatment.
- Process and analyze the cells in the same manner as the experimental samples.
- Expected Result: The vehicle control should not produce a signal significantly above the background level established by the no-labeling control.

Protocol 3: Competition with Excess Unlabeled Arachidonic Acid

Objective: To verify that AA-alkyne is incorporated through the same cellular uptake and metabolic pathways as natural arachidonic acid.

Methodology:

- Culture cells to the desired confluency.
- Pre-incubate the cells for 1-2 hours with varying concentrations of unlabeled arachidonic acid (e.g., 10x, 50x, 100x molar excess relative to the AA-alkyne concentration).
- Add the AA-alkyne to the media, maintaining the excess of unlabeled arachidonic acid, and incubate for the desired labeling period.
- Wash the cells thoroughly to remove unincorporated fatty acids.
- Lyse the cells and perform the click chemistry reaction.
- Analyze the signal from the incorporated AA-alkyne.
- Expected Result: A dose-dependent reduction in the signal from AA-alkyne should be observed with increasing concentrations of unlabeled arachidonic acid, indicating successful competition for the same metabolic pathways.

Visualizing Experimental Workflows and Pathways

To further clarify the experimental logic and the metabolic context, the following diagrams are provided.

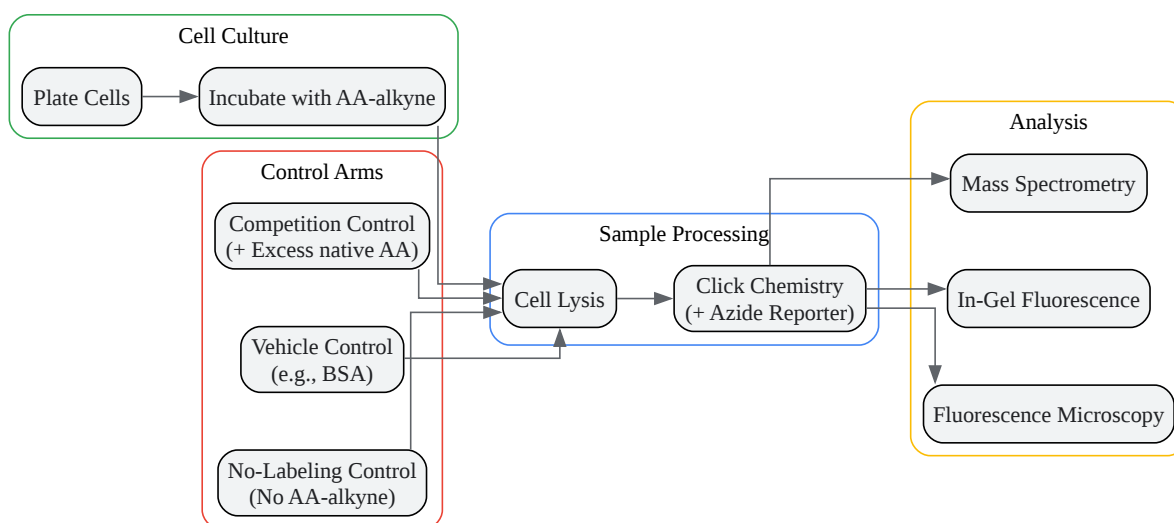

[Click to download full resolution via product page](#)

Figure 1. Experimental workflow for AA-alkyne labeling with controls.

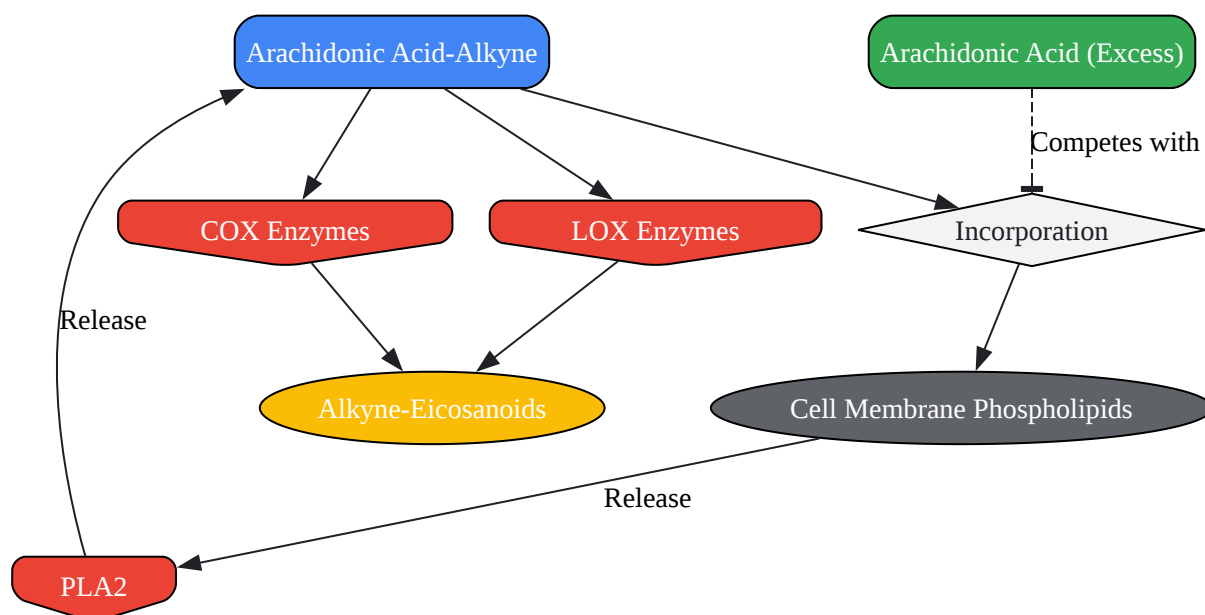

[Click to download full resolution via product page](#)

Need Custom Synthesis?

BenchChem offers custom synthesis for rare earth carbides and specific isotopic labeling.

Email: info@benchchem.com or [Request Quote Online](#).

References

- 1. Deuterated Arachidonic Acid Ameliorates Lipopolysaccharide-Induced Lung Damage in Mice - PMC [[pmc.ncbi.nlm.nih.gov](https://pubmed.ncbi.nlm.nih.gov/)]
- 2. Arachidonic acid: reconciling the dichotomy of its oxidative cascade through specific deuteration - PubMed [pubmed.ncbi.nlm.nih.gov]
- 3. On the cellular metabolism of the click chemistry probe 19-alkyne arachidonic acid - PubMed [pubmed.ncbi.nlm.nih.gov]
- To cite this document: BenchChem. [A Researcher's Guide to Control Experiments for Arachidonic Acid-Alkyne Labeling]. BenchChem, [2025]. [Online PDF]. Available at:

[<https://www.benchchem.com/product/b15572622#control-experiments-for-arachidonic-acid-alkyne-labeling>]

Disclaimer & Data Validity:

The information provided in this document is for Research Use Only (RUO) and is strictly not intended for diagnostic or therapeutic procedures. While BenchChem strives to provide accurate protocols, we make no warranties, express or implied, regarding the fitness of this product for every specific experimental setup.

Technical Support: The protocols provided are for reference purposes. Unsure if this reagent suits your experiment? [[Contact our Ph.D. Support Team for a compatibility check](#)]

Need Industrial/Bulk Grade? [Request Custom Synthesis Quote](#)

BenchChem

Our mission is to be the trusted global source of essential and advanced chemicals, empowering scientists and researchers to drive progress in science and industry.

Contact

Address: 3281 E Guasti Rd
Ontario, CA 91761, United States
Phone: (601) 213-4426
Email: info@benchchem.com