

# Application Notes and Protocols for Angiogenin (108-122) Research in Animal Models

**Author:** BenchChem Technical Support Team. **Date:** April 2026

## Compound of Interest

Compound Name: *Angiogenin (108-122)*

Cat. No.: *B15571401*

[Get Quote](#)

For Researchers, Scientists, and Drug Development Professionals

These application notes provide a comprehensive overview of the use of animal models in research involving the **Angiogenin (108-122)** peptide. Angiogenin (ANG) is a potent mediator of new blood vessel formation (angiogenesis) and is implicated in various physiological and pathological processes, including tumor growth, neuroprotection, and inflammation. The C-terminal peptide fragment, **Angiogenin (108-122)**, has been identified as an inhibitor of ANG's biological activities, making it a molecule of significant interest for therapeutic development.

This document outlines key animal models, detailed experimental protocols, and the known signaling pathways associated with Angiogenin, providing a valuable resource for designing and conducting in vivo studies with the **Angiogenin (108-122)** peptide.

## I. Overview of Relevant Animal Models

Several animal models have been utilized to study the function of full-length Angiogenin. While specific protocols for the **Angiogenin (108-122)** peptide are less common in published literature, the existing models for ANG provide a strong foundation for investigating the inhibitory effects of this peptide.

Animal Model	Research Area	Key Features	Potential Application for Angiogenin (108-122)
Chick Chorioallantoic Membrane (CAM)	Angiogenesis	Highly vascularized extraembryonic membrane of a chicken embryo, allowing for direct visualization and quantification of angiogenesis. Cost-effective and relatively simple to perform.[1] [2]	To assess the anti-angiogenic potential of the peptide by observing the inhibition of new blood vessel formation.
Mouse Models of Cancer	Tumor Growth & Angiogenesis	Xenograft models where human tumor cells are implanted into immunodeficient mice. Allows for the study of tumor growth, metastasis, and response to therapeutic agents.[3]	To evaluate the anti-tumor efficacy of the peptide by measuring its ability to inhibit tumor growth and vascularization.
Mouse Models of Neurodegenerative Diseases	Neuroprotection	Transgenic or toxin-induced models that mimic aspects of diseases like Parkinson's and ALS. Used to assess the therapeutic potential of neuroprotective agents.[4]	To investigate the potential neuroprotective effects of the peptide, possibly by inhibiting detrimental angiogenic processes or other ANG-mediated pathways in the central nervous system.

Rat Model of Uveitis	Anti-inflammatory Effects	Endotoxin-induced uveitis (EIU) model in rats, which mimics acute ocular inflammation.[5]	To determine the anti-inflammatory properties of the peptide by measuring the reduction in inflammatory markers. [5]
Mouse Models of Diabetic Wound Healing	Wound Healing & Angiogenesis	Genetically diabetic mice (e.g., db/db mice) with impaired wound healing capabilities.	To explore the peptide's role in modulating wound healing, particularly its potential to inhibit excessive or abnormal angiogenesis that can occur in diabetic wounds.

## II. Experimental Protocols

### A. Chick Chorioallantoic Membrane (CAM) Assay for Angiogenesis Inhibition

This protocol is adapted for testing the anti-angiogenic effects of **Angiogenin (108-122)**.

Materials:

- Fertilized chicken eggs
- Incubator (37.5°C, 60-70% humidity)
- Sterile phosphate-buffered saline (PBS)
- **Angiogenin (108-122)** peptide, sterile solution
- Positive control (e.g., a known angiogenesis inhibitor)
- Vehicle control (e.g., sterile PBS or the solvent used for the peptide)

- Thermanox® coverslips or sterile filter paper discs
- Ethanol (70%)
- Sterile forceps
- Small scissors or a rotary tool with a cutting wheel
- Stereomicroscope
- Digital camera for imaging
- Image analysis software (e.g., ImageJ)

#### Procedure:

- Egg Incubation: Incubate fertilized chicken eggs at 37.5°C with 60-70% humidity for 3 days.
- Windowing the Egg: On day 3, carefully create a small window (approximately 1 cm<sup>2</sup>) in the eggshell over the air sac. Use a rotary tool or small scissors to score the shell and then gently remove the piece of shell with sterile forceps.
- Application of Test Substance:
  - Prepare sterile Thermanox® coverslips or filter paper discs.
  - Apply a specific dose of the **Angiogenin (108-122)** peptide solution, positive control, or vehicle control to the center of the coverslip/disc. Allow it to air dry under sterile conditions.
  - Gently place the coverslip/disc directly onto the CAM, avoiding major blood vessels.
- Sealing and Re-incubation: Seal the window with sterile adhesive tape and return the eggs to the incubator.
- Observation and Imaging: On day 7 or 8 of incubation, open the window and observe the CAM under a stereomicroscope. Capture high-resolution images of the area around the coverslip/disc for each egg.

- Quantification of Angiogenesis:
  - Analyze the captured images using software like ImageJ.
  - Quantify the number of blood vessel branch points and the total length of blood vessels within a defined radius around the coverslip/disc.
  - Compare the results from the **Angiogenin (108-122)** treated group with the vehicle and positive control groups. A significant reduction in vessel branching and length indicates an anti-angiogenic effect.

## B. Murine Xenograft Model for Anti-Tumor Activity

This protocol provides a general framework for assessing the anti-tumor effects of **Angiogenin (108-122)**. Specific cell lines, mouse strains, and peptide dosages will need to be optimized.

Materials:

- Immunodeficient mice (e.g., athymic nude or SCID mice)
- Human tumor cell line known to be responsive to Angiogenin (e.g., certain colon, lung, or bladder cancer cell lines)[3]
- Cell culture medium and supplements
- Matrigel or similar basement membrane matrix
- **Angiogenin (108-122)** peptide, sterile solution for injection
- Vehicle control
- Calipers for tumor measurement
- Anesthesia

Procedure:

- Cell Preparation: Culture the chosen human tumor cell line under standard conditions. On the day of injection, harvest the cells and resuspend them in a mixture of sterile PBS and

Matrigel.

- Tumor Cell Implantation: Anesthetize the mice and subcutaneously inject the tumor cell suspension (typically  $1-5 \times 10^6$  cells) into the flank of each mouse.
- Treatment Administration:
  - Once tumors reach a palpable size (e.g., 50-100 mm<sup>3</sup>), randomize the mice into treatment and control groups.
  - Administer the **Angiogenin (108-122)** peptide or vehicle control via a suitable route (e.g., intraperitoneal, intravenous, or subcutaneous injection). The dosage and frequency of administration will need to be determined through dose-response studies.
- Tumor Growth Monitoring: Measure the tumor dimensions with calipers every 2-3 days and calculate the tumor volume using the formula:  $(\text{Length} \times \text{Width}^2) / 2$ .
- Endpoint and Analysis:
  - At the end of the study (based on tumor size limits or a predetermined time point), euthanize the mice and excise the tumors.
  - Weigh the tumors and process them for further analysis (e.g., histology, immunohistochemistry for markers of angiogenesis like CD31, and apoptosis).
  - Compare the tumor growth rates and final tumor weights between the treatment and control groups to assess the anti-tumor efficacy of **Angiogenin (108-122)**.

### III. Signaling Pathways

The **Angiogenin (108-122)** peptide is understood to function primarily by inhibiting the activity of full-length Angiogenin. Therefore, to comprehend the mechanism of the peptide, it is essential to understand the signaling pathways activated by ANG.

#### A. Angiogenin-Induced Pro-Angiogenic Signaling

Full-length Angiogenin promotes angiogenesis through a multi-step process that involves both extracellular and intracellular signaling events.

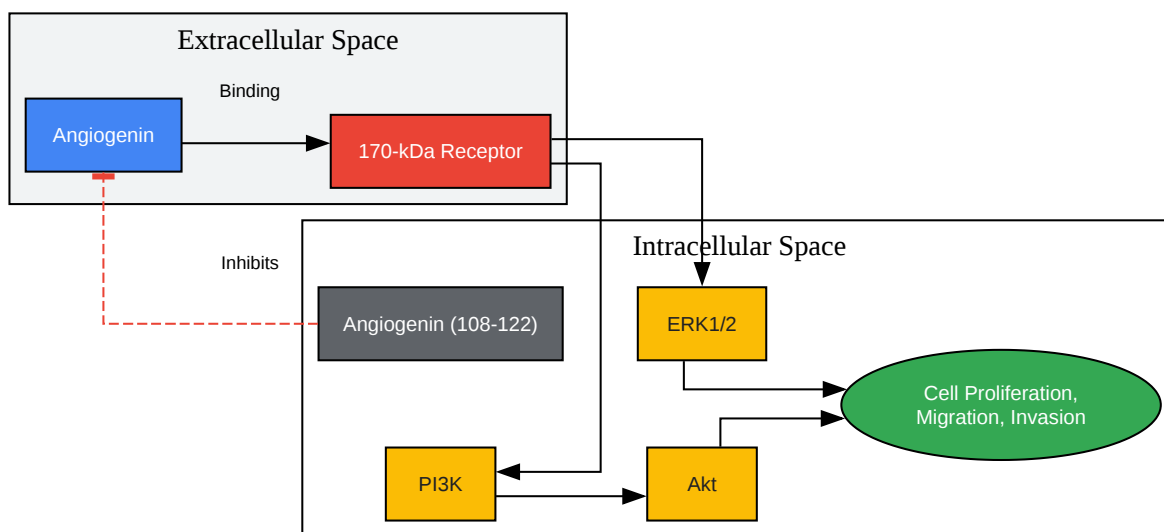

[Click to download full resolution via product page](#)

Caption: Angiogenin signaling pathway leading to angiogenesis.

Full-length Angiogenin binds to a putative 170-kDa receptor on the surface of endothelial cells. [6][7][8] This interaction triggers downstream signaling cascades, including the activation of the PI3K/Akt and ERK1/2 pathways.[9] These pathways are crucial for promoting endothelial cell proliferation, migration, and invasion, which are all essential steps in the formation of new blood vessels.[6][7][8] The **Angiogenin (108-122)** peptide is thought to exert its anti-angiogenic effects by interfering with the binding of Angiogenin to its receptor, thereby inhibiting these downstream signaling events.

## B. Angiogenin in Inflammation (NF- $\kappa$ B Pathway)

In certain contexts, such as in a rat model of endotoxin-induced uveitis, full-length Angiogenin has been shown to have anti-inflammatory effects by modulating the NF- $\kappa$ B signaling pathway. [5]

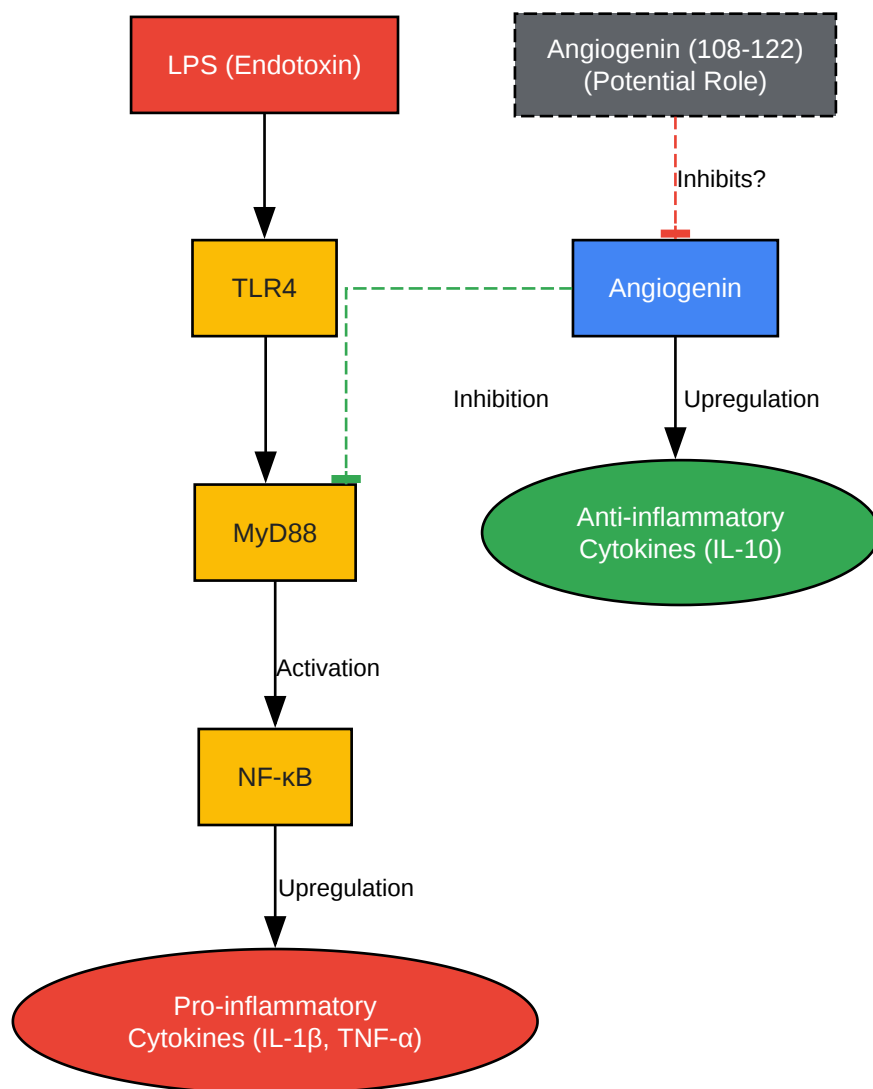

[Click to download full resolution via product page](#)

Caption: Angiogenin's modulation of the NF-κB inflammatory pathway.

In this model, lipopolysaccharide (LPS) activates the Toll-like receptor 4 (TLR4), leading to the recruitment of the adaptor protein MyD88 and subsequent activation of the transcription factor NF-κB.[5] This results in the production of pro-inflammatory cytokines. Full-length Angiogenin has been shown to inhibit this pathway, leading to a decrease in pro-inflammatory cytokines and an increase in anti-inflammatory cytokines.[5] The role of **Angiogenin (108-122)** in this context has not been extensively studied, but it could potentially counteract the anti-inflammatory effects of endogenous Angiogenin by inhibiting its action.

## IV. Data Presentation

While specific quantitative data for **Angiogenin (108-122)** is limited, the following tables provide examples of how to structure data from in vivo studies based on research with full-length Angiogenin and its inhibitors.

Table 1: Effect of **Angiogenin (108-122)** on Angiogenesis in the CAM Assay

Treatment Group	Concentration	Number of Branch Points (mean ± SEM)	Total Vessel Length (mm, mean ± SEM)	% Inhibition of Angiogenesis
Vehicle Control	-	Data to be collected	Data to be collected	0%
Angiogenin (108-122)	Dose 1	Data to be collected	Data to be collected	Calculate
Angiogenin (108-122)	Dose 2	Data to be collected	Data to be collected	Calculate
Positive Control	Specify	Data to be collected	Data to be collected	Calculate

Table 2: Anti-Tumor Efficacy of **Angiogenin (108-122)** in a Xenograft Model

Treatment Group	Dose and Schedule	Final Tumor Volume (mm <sup>3</sup> , mean ± SEM)	Final Tumor Weight (g, mean ± SEM)	% Tumor Growth Inhibition
Vehicle Control	-	Data to be collected	Data to be collected	0%
Angiogenin (108-122)	Dose 1	Data to be collected	Data to be collected	Calculate
Angiogenin (108-122)	Dose 2	Data to be collected	Data to be collected	Calculate
Positive Control	Specify	Data to be collected	Data to be collected	Calculate

## V. Conclusion

The **Angiogenin (108-122)** peptide presents a promising avenue for therapeutic intervention in diseases characterized by excessive angiogenesis or other pathological activities of Angiogenin. The animal models and protocols outlined in these application notes provide a solid framework for investigating the in vivo efficacy and mechanism of action of this peptide. Further research is warranted to establish optimal dosing, administration routes, and to fully elucidate the signaling pathways modulated by **Angiogenin (108-122)** in various disease contexts. The use of these models will be crucial in advancing the development of Angiogenin-based therapeutics.

### *Need Custom Synthesis?*

*BenchChem offers custom synthesis for rare earth carbides and specific isotopic labeling.*

*Email: [info@benchchem.com](mailto:info@benchchem.com) or [Request Quote Online](#).*

## References

- [1. mdpi.com \[mdpi.com\]](https://www.mdpi.com)
- [2. Protocol for performing angiogenic and tumorigenic assays using the in ovo chick embryo chorioallantoic membrane model - PMC \[pmc.ncbi.nlm.nih.gov\]](#)
- [3. Angiogenin promotes tumoral growth and angiogenesis by regulating matrix metalloproteinase-2 expression via the ERK1/2 pathway - PMC \[pmc.ncbi.nlm.nih.gov\]](#)
- [4. A neuroprotective role for angiogenin in models of Parkinson's disease - PubMed \[pubmed.ncbi.nlm.nih.gov\]](#)
- [5. The Anti-Inflammatory Effects of Angiogenin in an Endotoxin Induced Uveitis in Rats - PMC \[pmc.ncbi.nlm.nih.gov\]](#)
- [6. Mechanisms of action of angiogenin. | Semantic Scholar \[semanticscholar.org\]](#)
- [7. Mechanisms of action of angiogenin - PubMed \[pubmed.ncbi.nlm.nih.gov\]](#)
- [8. researchgate.net \[researchgate.net\]](https://www.researchgate.net)
- [9. Three decades of research on angiogenin: a review and perspective - PMC \[pmc.ncbi.nlm.nih.gov\]](#)
- [To cite this document: BenchChem. \[Application Notes and Protocols for Angiogenin \(108-122\) Research in Animal Models\]. BenchChem, \[2026\]. \[Online PDF\]. Available at:](#)

[\[https://www.benchchem.com/product/b15571401/docs#application-notes-and-protocols-for-angiogenin-108-122-research-in-animal-models\]](https://www.benchchem.com/product/b15571401/docs#application-notes-and-protocols-for-angiogenin-108-122-research-in-animal-models)

**Disclaimer & Data Validity:**

The information provided in this document is for Research Use Only (RUO) and is strictly not intended for diagnostic or therapeutic procedures. While BenchChem strives to provide accurate protocols, we make no warranties, express or implied, regarding the fitness of this product for every specific experimental setup.

**Technical Support:** The protocols provided are for reference purposes. Unsure if this reagent suits your experiment?

**Need Industrial/Bulk Grade?** [Request Custom Synthesis Quote](#)

## BenchChem

Our mission is to be the trusted global source of essential and advanced chemicals, empowering scientists and researchers to drive progress in science and industry.

### Contact

Address: 3281 E Guasti Rd  
Ontario, CA 91761, United States  
Phone: (601) 213-4426  
Email: [info@benchchem.com](mailto:info@benchchem.com)

[Contact our Ph.D. Support Team for a compatibility check](#)