

# Application Notes and Protocols for Angiogenin (108-122) Peptide

**Author:** BenchChem Technical Support Team. **Date:** April 2026

## Compound of Interest

Compound Name: Angiogenin (108-122)

Cat. No.: B15571401

[Get Quote](#)

For Researchers, Scientists, and Drug Development Professionals

These application notes provide detailed protocols for the proper dissolution, storage, and handling of the **Angiogenin (108-122)** peptide. Additionally, experimental protocols for assessing its biological activity and an overview of the relevant signaling pathways are included to facilitate its use in research and drug development.

## Product Information

- Peptide Name: **Angiogenin (108-122)**
- Sequence: Glu-Asn-Gly-Leu-Pro-Val-His-Leu-Asp-Gln-Ser-Ile-Phe-Arg-Arg
- Molecular Weight: 1780.98 g/mol
- Appearance: Lyophilized white powder
- Biological Activity: Inhibitor of Angiogenin's biological and enzymatic activities.[\[1\]](#)

## Dissolution and Storage Protocols

Proper handling and storage of the **Angiogenin (108-122)** peptide are critical to maintain its stability and biological activity.

## Reconstitution of Lyophilized Peptide

Materials:

- Lyophilized **Angiogenin (108-122)** peptide vial
- Sterile, high-purity water (e.g., Milli-Q or WFI)
- Sterile pipette tips and tubes
- (Optional) DMSO or 0.1% acetic acid for peptides that are difficult to dissolve

Protocol:

- Before opening, allow the vial of lyophilized peptide to equilibrate to room temperature for at least 20-30 minutes.[2] This prevents condensation from forming inside the vial, which can affect peptide stability.
- Work in a sterile environment (e.g., a laminar flow hood) to prevent microbial contamination.
- Carefully open the vial.
- To prepare a stock solution, add the appropriate volume of sterile water to the vial. **Angiogenin (108-122)** is generally soluble in water.[3]
- Gently swirl or roll the vial to dissolve the peptide. Do not shake or vortex, as this can cause aggregation. If the peptide does not readily dissolve, brief sonication may be helpful.
- For peptides that are difficult to dissolve in water, a small amount of DMSO can be used to initially solubilize the peptide, followed by dilution with sterile water to the desired concentration.[4] Alternatively, for basic peptides, 10% acetic acid can be attempted, and for acidic peptides, 10% ammonium bicarbonate can be used.

## Storage Conditions

The stability of the **Angiogenin (108-122)** peptide is dependent on the storage conditions.

Form	Storage Temperature	Duration	Notes
Lyophilized Powder	-20°C	Up to 3 years	Keep away from moisture.[3]
	-80°C	Long-term	For maximum stability.
In Solvent	-80°C	Up to 1 year	Aliquoting is highly recommended to avoid repeated freeze-thaw cycles.[3]
	-20°C	Up to 3-4 months	Avoid using frost-free freezers due to temperature fluctuations.
	4°C	1-2 weeks	For short-term use only.

## Experimental Protocols

**Angiogenin (108-122)** has been shown to inhibit the angiogenic activity of full-length Angiogenin. The following are example protocols for assessing this inhibitory effect.

### In Vitro Endothelial Cell Tube Formation Assay

This assay assesses the ability of endothelial cells to form capillary-like structures (tubes) in vitro, a key step in angiogenesis. The inhibitory potential of **Angiogenin (108-122)** can be quantified by its effect on tube formation induced by Angiogenin.

Materials:

- Human Umbilical Vein Endothelial Cells (HUVECs)
- Endothelial Cell Growth Medium

- Basement Membrane Extract (BME), such as Matrigel®
- Recombinant human Angiogenin
- **Angiogenin (108-122)** peptide stock solution
- 96-well culture plate
- Incubator (37°C, 5% CO<sub>2</sub>)
- Inverted microscope with a camera

Protocol:

- Thaw the BME on ice overnight. Pre-chill a 96-well plate and pipette tips at -20°C.
- Pipette 50 µL of the cold, liquid BME into each well of the pre-chilled 96-well plate. Ensure the BME is evenly spread across the bottom of the wells.
- Incubate the plate at 37°C for 30-60 minutes to allow the BME to solidify.
- Harvest HUVECs and resuspend them in serum-free medium at a concentration of  $2 \times 10^5$  cells/mL.[5]
- Prepare the following treatment groups in separate tubes:
  - Negative Control: HUVEC suspension only.
  - Positive Control: HUVEC suspension + recombinant Angiogenin (e.g., 100 ng/mL).
  - Inhibitor Group(s): HUVEC suspension + recombinant Angiogenin + varying concentrations of **Angiogenin (108-122)** peptide.
- Gently add 100 µL of the cell suspension for each treatment group to the BME-coated wells.
- Incubate the plate at 37°C in a 5% CO<sub>2</sub> incubator for 4-18 hours.
- Monitor tube formation using an inverted microscope at regular intervals.

- Capture images of the tube networks.
- Quantify the extent of tube formation by measuring parameters such as the number of branch points, total tube length, and number of loops using image analysis software (e.g., ImageJ).

## Chick Chorioallantoic Membrane (CAM) Assay

The CAM assay is an in vivo model to study angiogenesis. The inhibitory effect of **Angiogenin (108-122)** on Angiogenin-induced neovascularization can be observed directly.<sup>[6]</sup>

Materials:

- Fertilized chicken eggs (Day 3 of incubation)
- Egg incubator (37.5°C, 85% humidity)
- Sterile saline
- Recombinant human Angiogenin
- **Angiogenin (108-122)** peptide stock solution
- Thermostable, non-toxic carrier (e.g., sterile filter paper discs or a slow-release polymer)
- Stereomicroscope
- Sterile tools for creating a window in the eggshell

Protocol:

- Incubate fertilized chicken eggs at 37.5°C with 85% humidity.
- On day 3 of incubation, carefully create a small window in the eggshell to expose the CAM.
- Prepare the treatment discs:
  - Negative Control: Disc with sterile saline.

- Positive Control: Disc with recombinant Angiogenin.
- Inhibitor Group: Disc with recombinant Angiogenin and **Angiogenin (108-122)** peptide.
- Gently place the prepared discs onto the CAM surface.
- Seal the window with sterile tape and return the eggs to the incubator.
- After 48-72 hours, re-open the window and observe the CAM under a stereomicroscope.
- Capture images of the area around the discs.
- Quantify angiogenesis by counting the number of blood vessels converging towards the disc. A significant reduction in vessel formation in the inhibitor group compared to the positive control indicates anti-angiogenic activity.

## Quantitative Data Summary

The following table summarizes available quantitative data for the inhibitory activity of C-terminal Angiogenin peptides.

Peptide	Assay	Parameter	Value	Reference
Angiogenin (108-123)	tRNA Degradation Assay	Apparent Inhibition Constant (K <sub>i</sub> )	278 μM	[7]
Angiogenin (108-122)	Ribonucleolytic Activity Assay (tRNA substrate)	% Inhibition	39%	[8]
chANG and chGNA (peptide antagonists)	Binding Assay	Dissociation Constant (K <sub>d</sub> )	~44 nM	[9]

## Signaling Pathways and Mechanism of Action

Angiogenin promotes angiogenesis through several mechanisms. The **Angiogenin (108-122)** peptide is thought to inhibit these processes.

## Angiogenin Signaling Pathway

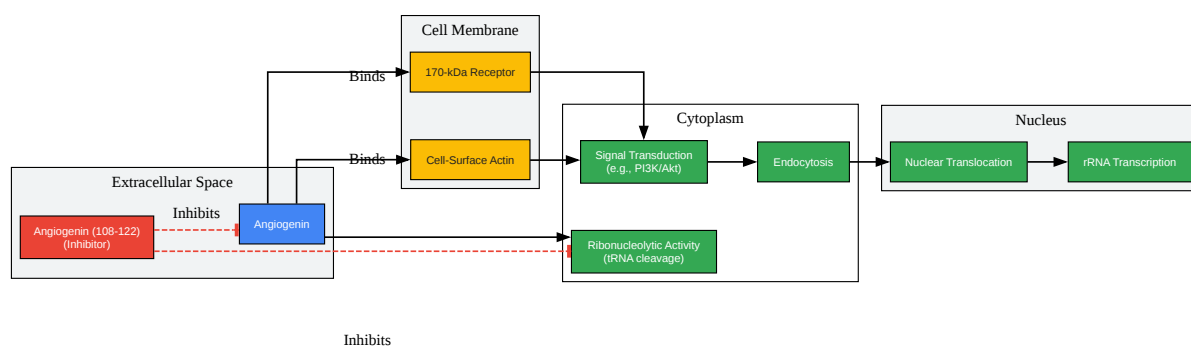

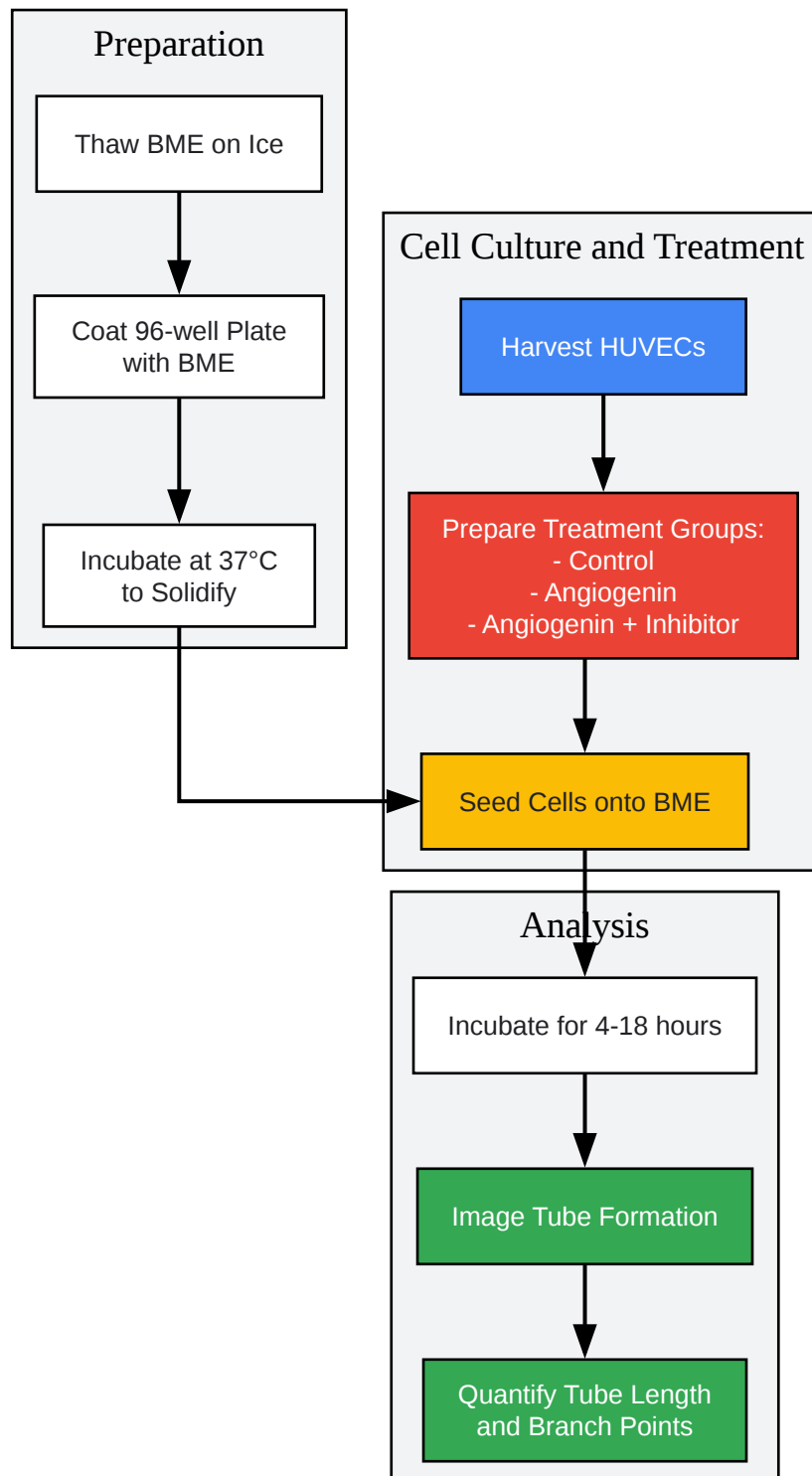

[Click to download full resolution via product page](#)

**Need Custom Synthesis?**

BenchChem offers custom synthesis for rare earth carbides and specific isotopic labeling.

Email: [info@benchchem.com](mailto:info@benchchem.com) or [Request Quote Online](#).

## References

- [1. medchemexpress.com \[medchemexpress.com\]](https://www.medchemexpress.com)
- [2. Angiogenesis | Cell Signaling Technology \[cellsignal.com\]](https://www.cellsignal.com)
- [3. Protocol for performing angiogenic and tumorigenic assays using the in ovo chick embryo chorioallantoic membrane model - PMC \[pmc.ncbi.nlm.nih.gov\]](https://pubmed.ncbi.nlm.nih.gov/112173485/)
- [4. researchgate.net \[researchgate.net\]](https://www.researchgate.net)
- [5. yeasenbio.com \[yeasenbio.com\]](https://www.yeasenbio.com)
- [6. C-terminal angiogenin peptides inhibit the biological and enzymatic activities of angiogenin - PubMed \[pubmed.ncbi.nlm.nih.gov\]](https://pubmed.ncbi.nlm.nih.gov/112173485/)
- [7. Buy ANGIOGENIN \(108-123\) | 112173-48-5 \[smolecule.com\]](https://www.smolecule.com)
- [8. medchemexpress.cn \[medchemexpress.cn\]](https://www.medchemexpress.cn)
- [9. Anti-angiogenin activity of the peptides complementary to the receptor-binding site of angiogenin - PubMed \[pubmed.ncbi.nlm.nih.gov\]](https://pubmed.ncbi.nlm.nih.gov/112173485/)
- To cite this document: BenchChem. [Application Notes and Protocols for Angiogenin (108-122) Peptide]. BenchChem, [2026]. [Online PDF]. Available at: [\[https://www.benchchem.com/product/b15571401/docs#application-notes-and-protocols-for-angiogenin-108-122-peptide\]](https://www.benchchem.com/product/b15571401/docs#application-notes-and-protocols-for-angiogenin-108-122-peptide)

---

**Disclaimer & Data Validity:**

The information provided in this document is for Research Use Only (RUO) and is strictly not intended for diagnostic or therapeutic procedures. While BenchChem strives to provide accurate protocols, we make no warranties, express or implied, regarding the fitness of this product for every specific experimental setup.

**Technical Support:** The protocols provided are for reference purposes. Unsure if this reagent suits your experiment?

**Need Industrial/Bulk Grade?** [Request Custom Synthesis Quote](#)

## BenchChem

Our mission is to be the trusted global source of essential and advanced chemicals, empowering scientists and researchers to drive progress in science and industry.

### Contact

Address: 3281 E Guasti Rd  
Ontario, CA 91761, United States  
Phone: (601) 213-4426  
Email: [info@benchchem.com](mailto:info@benchchem.com)

[Contact our Ph.D. Support Team for a compatibility check](#)