

Application Notes: Bet BD2-IN-3 for Cell-Based Assays

Author: BenchChem Technical Support Team. **Date:** April 2026

Compound of Interest

Compound Name: *Bet BD2-IN-3*

Cat. No.: *B15571018*

[Get Quote](#)

For Researchers, Scientists, and Drug Development Professionals

Introduction

The Bromodomain and Extra-Terminal (BET) family of proteins, comprising BRD2, BRD3, BRD4, and the testis-specific BRDT, are crucial epigenetic readers that regulate gene transcription.[1][2] These proteins contain two tandem N-terminal bromodomains, BD1 and BD2, which recognize and bind to acetylated lysine residues on histone tails and other proteins.[1][2] This interaction recruits transcriptional machinery to specific gene promoters and enhancers, playing a key role in cell cycle progression, proliferation, and oncogenesis.[2] The profound involvement of BET proteins, particularly BRD4, in the expression of key oncogenes like c-MYC has made them attractive targets for cancer therapy.

Bet BD2-IN-3 is a potent, small-molecule inhibitor with high selectivity for the second bromodomain (BD2) of BET family proteins. While pan-BET inhibitors have shown promise, they can also be associated with on-target toxicities, such as thrombocytopenia and gastrointestinal issues. The development of domain-selective inhibitors like **Bet BD2-IN-3** allows for the dissection of the distinct biological functions of BD1 and BD2 and may offer a therapeutic window with an improved safety profile. Studies suggest that while BD1 is essential

for maintaining steady-state gene expression, BD2 is more critical for the induced expression of certain genes, particularly in the context of inflammation and some cancers. These application notes provide detailed protocols for utilizing **Bet BD2-IN-3** in various cell culture experiments to probe its anti-proliferative and mechanistic effects.

Mechanism of Action

Bet BD2-IN-3 competitively binds to the acetyl-lysine binding pocket of the BD2 domain of BET proteins. This prevents the tethering of BET proteins to chromatin, leading to the displacement of transcriptional regulators, such as the positive transcription elongation factor b (P-TEFb), from the promoters and enhancers of target genes. A primary consequence of this inhibition is the rapid downregulation of the transcription of the master oncogene c-MYC. The subsequent reduction in c-MYC protein levels leads to cell cycle arrest, typically at the G1 phase, cellular senescence, and apoptosis in susceptible cancer cell lines.

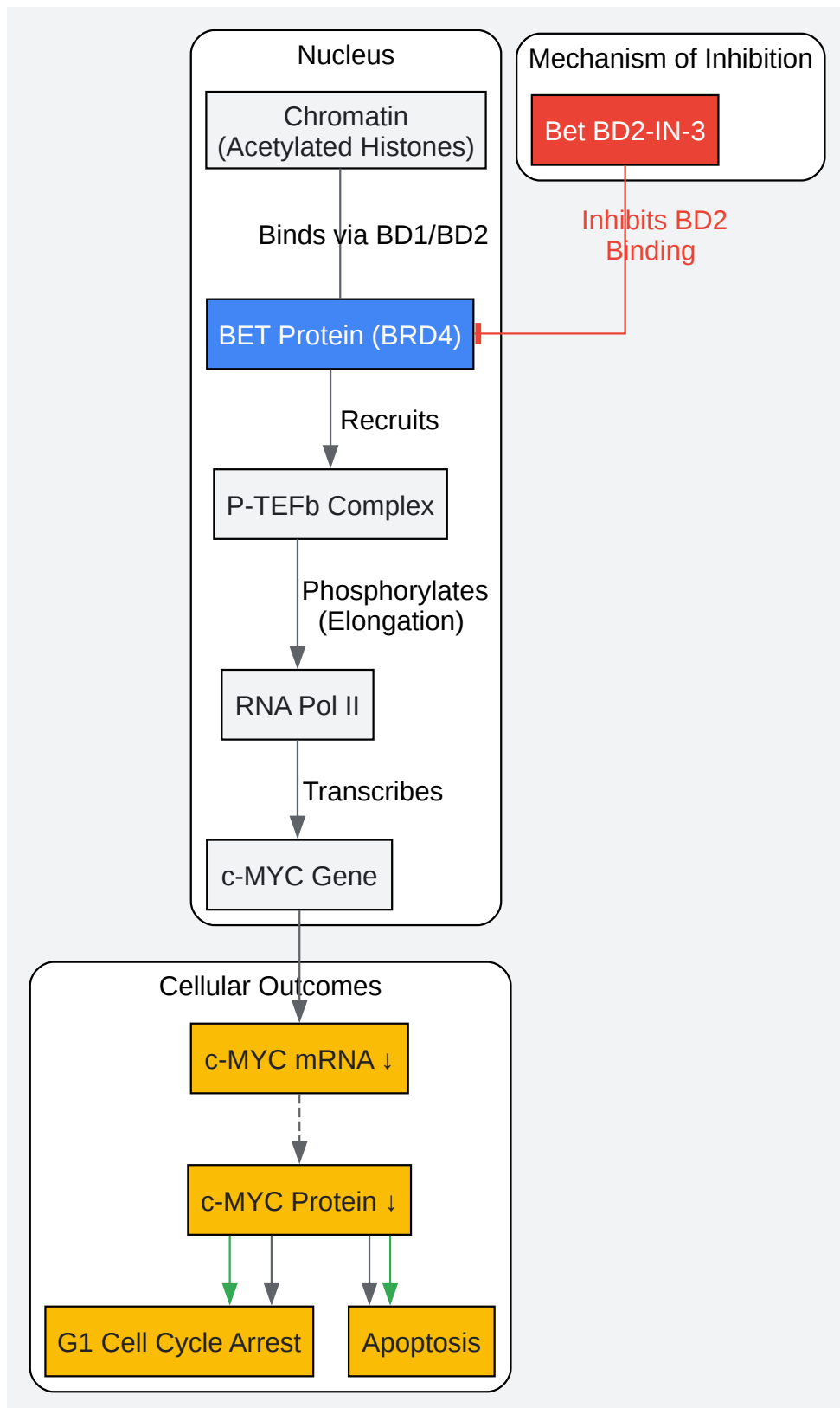

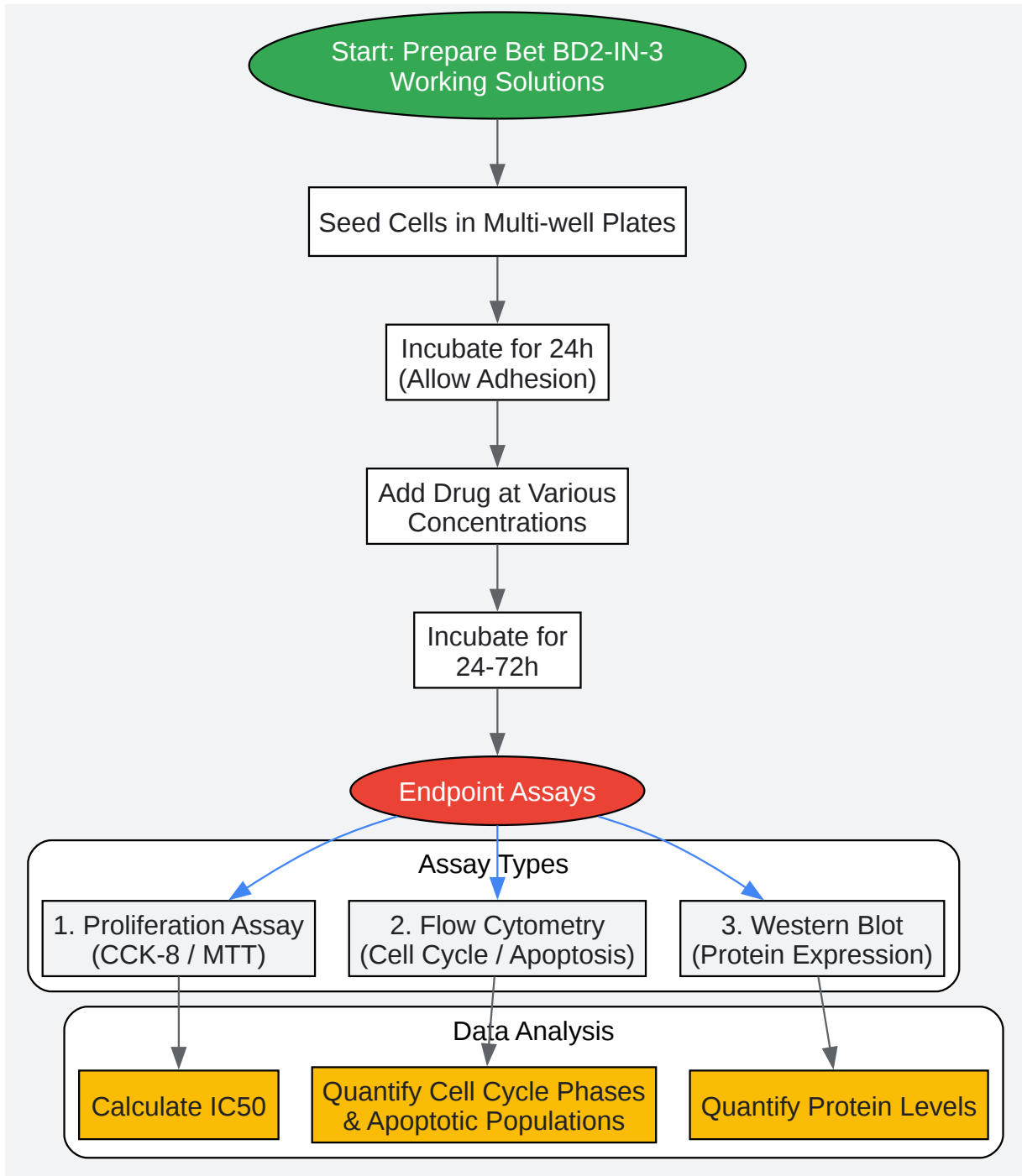

[Click to download full resolution via product page](#)

Need Custom Synthesis?

BenchChem offers custom synthesis for rare earth carbides and specific isotopic labeling.

Email: info@benchchem.com or [Request Quote Online](#).

References

- 1. BET Bromodomain Inhibitors: Novel Design Strategies and Therapeutic Applications - PMC [[pmc.ncbi.nlm.nih.gov](https://pubmed.ncbi.nlm.nih.gov/)]
- 2. Achieving clinical success with BET inhibitors as anti-cancer agents - PMC [[pmc.ncbi.nlm.nih.gov](https://pubmed.ncbi.nlm.nih.gov/)]
- To cite this document: BenchChem. [Application Notes: Bet BD2-IN-3 for Cell-Based Assays]. BenchChem, [2026]. [Online PDF]. Available at: [<https://www.benchchem.com/product/b15571018/docs#application-notes-bet-bd2-in-3-for-cell-based-assays>]

Disclaimer & Data Validity:

The information provided in this document is for Research Use Only (RUO) and is strictly not intended for diagnostic or therapeutic procedures. While BenchChem strives to provide accurate protocols, we make no warranties, express or implied, regarding the fitness of this product for every specific experimental setup.

Technical Support: The protocols provided are for reference purposes. Unsure if this reagent suits your experiment?

Need Industrial/Bulk Grade? [Request Custom Synthesis Quote](#)

BenchChem

Our mission is to be the trusted global source of essential and advanced chemicals, empowering scientists and researchers to drive progress in science and industry.

Contact

Address: 3281 E Guasti Rd

Ontario, CA 91761, United States

Phone: (601) 213-4426

Email: info@benchchem.com

[Contact our Ph.D. Support Team for a compatibility check](#)