

Application Notes: ATP Dipotassium Salt in Cell-Free Protein Synthesis

Author: BenchChem Technical Support Team. **Date:** April 2026

Compound of Interest

Compound Name: ATP dipotassium

CAS No.: 29622-22-8

Cat. No.: B15571057

[Get Quote](#)

Introduction

Cell-free protein synthesis (CFPS) has emerged as a powerful and versatile platform for rapid and efficient protein production. By harnessing the transcriptional and translational machinery of the cell in an in vitro environment, CFPS systems offer several advantages over traditional in vivo expression methods. These include the ability to synthesize toxic proteins, simplified purification processes, and precise control over the reaction environment. A critical component of any CFPS system is a sustained energy source, primarily supplied in the form of Adenosine 5'-triphosphate (ATP). **ATP dipotassium** salt is a commonly used, highly soluble, and stable form of ATP that provides the necessary energy for the demanding processes of transcription and translation.

These application notes provide a comprehensive overview of the role and application of **ATP dipotassium** salt in CFPS, complete with detailed protocols, quantitative data on its impact on protein yield, and workflow diagrams for researchers, scientists, and drug development professionals.

The Role of ATP in Cell-Free Protein Synthesis

ATP is the primary energy currency in CFPS, driving several key processes:

- **Transcription:** ATP is one of the four nucleotide triphosphates (NTPs) required for the synthesis of messenger RNA (mRNA) from a DNA template by RNA polymerase.
- **tRNA Aminoacylation:** The attachment of amino acids to their corresponding transfer RNA (tRNA) molecules is an energy-intensive process catalyzed by aminoacyl-tRNA synthetases, which requires the hydrolysis of ATP to AMP and pyrophosphate.
- **Translation Initiation, Elongation, and Termination:** The various steps of protein synthesis on the ribosome, including the binding of initiator tRNA, the translocation of the ribosome along the mRNA, and the release of the completed polypeptide chain, are facilitated by GTP, which is regenerated from GDP using ATP.

Due to its central role, the concentration and regeneration of ATP are critical parameters for optimizing protein yields in CFPS reactions.

Optimizing ATP Concentration

The optimal concentration of **ATP dipotassium** salt can vary depending on the specific CFPS system (e.g., *E. coli*, wheat germ, rabbit reticulocyte) and the protein being expressed.

Generally, ATP concentrations in the range of 1-2 mM are used. However, it is crucial to co-optimize the concentration of magnesium ions (Mg^{2+}), as ATP readily chelates Mg^{2+} , and the Mg^{2+} -ATP complex is the active form for many enzymes. An excess of free ATP can inhibit translation by sequestering available Mg^{2+} .

A common issue in batch CFPS reactions is the accumulation of inorganic phosphate (Pi) from ATP hydrolysis, which can inhibit protein synthesis. To counteract this, various ATP regeneration systems have been developed to maintain a stable supply of ATP throughout the reaction.

ATP Regeneration Systems

To sustain protein synthesis over longer periods and achieve higher yields, ATP is continuously regenerated from ADP using a secondary energy source. Common ATP regeneration systems include:

- Creatine Phosphate/Creatine Kinase: Creatine phosphate serves as a phosphate donor to regenerate ATP from ADP, catalyzed by creatine kinase.
- Phosphoenolpyruvate (PEP)/Pyruvate Kinase: PEP is a high-energy phosphate compound that can efficiently regenerate ATP.
- Pyruvate/Pyruvate Oxidase: This system generates acetyl phosphate from pyruvate and inorganic phosphate, which then donates its phosphate group to ADP to form ATP. This system has the advantage of recycling inorganic phosphate, preventing its accumulation.[1]
- Glucose/Glycolysis: Utilizing the glycolytic pathway present in some cell extracts to generate ATP from glucose.

The choice of ATP regeneration system can significantly impact the duration and yield of the CFPS reaction.

Quantitative Data on ATP Concentration and Protein Yield

The concentration of ATP has a direct impact on the final protein yield. The following tables summarize data from studies on the effect of NTP/ATP concentration on the synthesis of Superfolder Green Fluorescent Protein (sfGFP) in an E. coli-based CFPS system.

Table 1: Effect of NTP Concentration on sfGFP Synthesis with Varying Cell Extract Concentrations

Cell Extract Concentration (mg/mL)	NTP Concentration (Relative to 1x*)	sfGFP Yield (µg/mL)
20	1x	~150
40	1x	~100
80	1x	~50
80	2x	~125
80	3x	~175

*1x NTP concentration corresponds to 1.0 mM ATP, 1.0 mM GTP, 0.67 mM CTP, and 0.67 mM UTP.[2] Data is estimated from graphical representations in the source publication.

Table 2: Effect of ATP and its Derivatives on sfGFP Synthesis with High Concentration Cell Extract (80 mg/mL)

Compound Added (in addition to other NTPs)	Concentration	sfGFP Yield ($\mu\text{g/mL}$)
NTP	1x	~50
NTP	3x	~175
ATP	3x equivalent	~150
ADP	3x equivalent	~100

Data is estimated from graphical representations in the source publication.[2][3]

Table 3: Protein Synthesis Rate at Various Constant ATP Concentrations

Constant [ATP] (mM)	Optimal [Mg^{2+}] (mM)	Rate of CAT Protein Synthesis ($\mu\text{g/mL/min}$)
0.027	12	2.9 ± 0.2
0.05	12	4.3 ± 0.3
0.1	14	5.8 ± 0.4
0.2	16	6.7 ± 0.5
0.5	18	7.0 ± 0.5
1.0	18	7.1 ± 0.5

CAT: Chloramphenicol Acetyltransferase. Data is from a continuous-exchange CFPS system.[1]

Experimental Protocols

Below are detailed protocols for preparing an E. coli S30 extract and performing a standard batch CFPS reaction, with a focus on the preparation and use of **ATP dipotassium** salt.

Protocol 1: Preparation of E. coli S30 Extract

This protocol is adapted from established methods for preparing highly active E. coli extracts for CFPS.

Materials:

- E. coli strain (e.g., BL21(DE3))
- 2x YTPG media
- S30 Buffer (10 mM Tris-acetate pH 8.2, 14 mM Magnesium acetate, 60 mM Potassium acetate, 2 mM DTT)
- Sonicator
- High-speed refrigerated centrifuge

Procedure:

- Inoculate a starter culture of E. coli in Luria-Bertani (LB) medium and grow overnight at 37°C.
- The next day, inoculate 1 L of 2x YTPG media with the overnight culture and grow at 37°C with vigorous shaking until the OD₆₀₀ reaches ~3.0.
- Harvest the cells by centrifugation at 5,000 x g for 15 minutes at 4°C.
- Wash the cell pellet three times with cold S30 buffer.
- Resuspend the cell pellet in 1 mL of cold S30 buffer per gram of wet cell paste.
- Lyse the cells by sonication on ice. The sonication parameters should be optimized for the specific instrument, aiming for a total energy input of 800-900 Joules for a 1.4 mL sample.
- Immediately after sonication, add DTT to a final concentration of 3 mM.

- Centrifuge the lysate at 18,000 x g for 10 minutes at 4°C to pellet cell debris.
- Carefully transfer the supernatant to a new tube.
- Perform a "runoff" reaction by incubating the supernatant at 37°C for 60 minutes with shaking to degrade endogenous mRNA and ribosomes.
- Centrifuge at 10,000 x g for 10 minutes at 4°C.
- Aliquot the supernatant (S30 extract), flash-freeze in liquid nitrogen, and store at -80°C.

Protocol 2: Preparation of Energy Solution with ATP Dipotassium Salt

Materials:

- **ATP dipotassium** salt (powder)
- GTP sodium salt (powder)
- CTP sodium salt (powder)
- UTP sodium salt (powder)
- Creatine phosphate
- Nuclease-free water

Procedure:

- To prepare a 10x concentrated energy solution, dissolve the following in nuclease-free water to the specified final concentrations:
 - **ATP dipotassium** salt: 12 mM
 - GTP, CTP, UTP: 9 mM each
 - Creatine phosphate: 200 mM

- Adjust the pH to 7.0-7.5 with a potassium hydroxide solution.
- Aliquot the energy solution and store at -80°C. Avoid repeated freeze-thaw cycles.

Protocol 3: Standard Batch Cell-Free Protein Synthesis Reaction

Materials:

- S30 extract (from Protocol 1)
- 10x Energy Solution (from Protocol 2)
- Amino acid mixture (20 amino acids, ~20 mM each)
- Potassium glutamate (~1 M stock)
- Magnesium acetate (~1 M stock)
- Creatine kinase
- T7 RNA Polymerase
- DNA template (plasmid or linear) encoding the protein of interest
- Nuclease-free water

Procedure:

- On ice, combine the following components in a microcentrifuge tube to the specified final concentrations for a 15 µL reaction:

Component	Stock Concentration	Volume to Add (μL)	Final Concentration
S30 Extract	-	5.0	~33% (v/v)
10x Energy Solution	10x	1.5	1x (1.2 mM ATP)
Amino Acid Mix	20 mM each	1.5	2 mM each
Potassium Glutamate	1 M	1.2	80 mM
Magnesium Acetate	1 M	0.18	12 mM
Creatine Kinase	10 mg/mL	0.3	0.2 mg/mL
T7 RNA Polymerase	1 mg/mL	0.2	~13 $\mu\text{g/mL}$
DNA Template	100 ng/ μL	1.0	~6.7 ng/ μL
Nuclease-free Water	-	4.12	-
Total Volume	15.0		

- Mix the reaction gently by pipetting.
- Incubate the reaction at 37°C for 2-4 hours. For some proteins, incubation at a lower temperature (e.g., 30°C) for a longer period (e.g., overnight) may improve folding and yield.
- After incubation, the reaction can be analyzed directly by SDS-PAGE or used for downstream applications.

Visualizing the Workflow and Energy Cycle

To better understand the process, the following diagrams illustrate the experimental workflow and the central role of ATP regeneration.

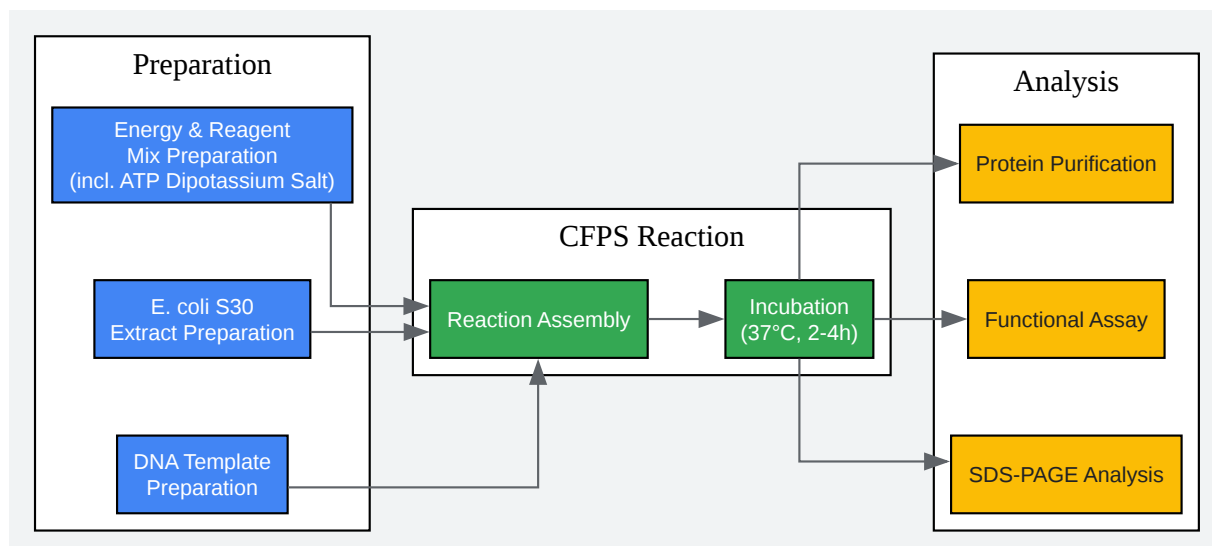

[Click to download full resolution via product page](#)

A high-level workflow for cell-free protein synthesis.

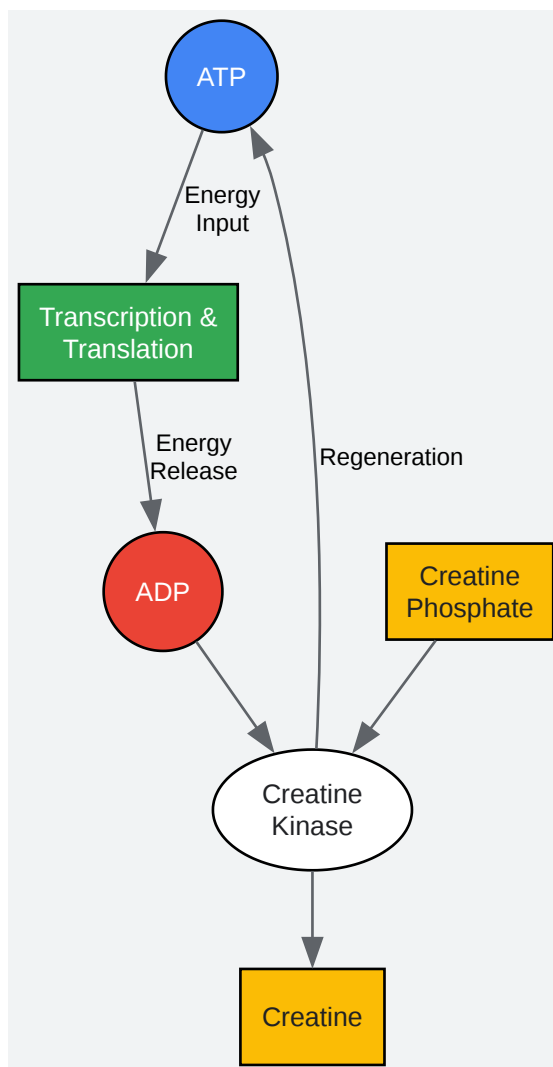

[Click to download full resolution via product page](#)

The ATP-ADP cycle with creatine phosphate regeneration.

Conclusion

ATP dipotassium salt is an indispensable component of cell-free protein synthesis systems, providing the essential energy for transcription and translation. The optimization of its concentration, in conjunction with magnesium ions and an efficient ATP regeneration system, is paramount for achieving high protein yields. The protocols and data presented here offer a solid foundation for researchers to successfully implement and optimize their CFPS experiments for a wide range of applications in basic science and drug development.

Need Custom Synthesis?

BenchChem offers custom synthesis for rare earth carbides and specific isotopic labeling.

Email: info@benchchem.com or [Request Quote Online](#).

References

- [1. journals.asm.org \[journals.asm.org\]](https://journals.asm.org)
- [2. A Relationship between NTP and Cell Extract Concentration for Cell-Free Protein Expression - PMC \[pmc.ncbi.nlm.nih.gov\]](https://pubmed.ncbi.nlm.nih.gov/)
- [3. mdpi.com \[mdpi.com\]](https://www.mdpi.com)
- To cite this document: BenchChem. [Application Notes: ATP Dipotassium Salt in Cell-Free Protein Synthesis]. BenchChem, [2026]. [Online PDF]. Available at: [\[https://www.benchchem.com/product/b15571057/docs#application-notes-atp-dipotassium-salt-in-cell-free-protein-synthesis\]](https://www.benchchem.com/product/b15571057/docs#application-notes-atp-dipotassium-salt-in-cell-free-protein-synthesis)

Disclaimer & Data Validity:

The information provided in this document is for Research Use Only (RUO) and is strictly not intended for diagnostic or therapeutic procedures. While BenchChem strives to provide accurate protocols, we make no warranties, express or implied, regarding the fitness of this product for every specific experimental setup.

Technical Support: The protocols provided are for reference purposes. Unsure if this reagent suits your experiment?

Need Industrial/Bulk Grade? [Request Custom Synthesis Quote](#)

BenchChem

Our mission is to be the trusted global source of essential and advanced chemicals, empowering scientists and researchers to drive progress in science and industry.

Contact

Address: 3281 E Guasti Rd
Ontario, CA 91761, United States
Phone: (601) 213-4426
Email: info@benchchem.com

[Contact our Ph.D. Support Team for a compatibility check](#)