

2-MeS-ATP as a P2Y Receptor Agonist: A Technical Guide

Author: BenchChem Technical Support Team. **Date:** April 2026

Compound of Interest

Compound Name: 2-MeS-ATP

Cat. No.: B15571884

[Get Quote](#)

For Researchers, Scientists, and Drug Development Professionals

This in-depth technical guide provides a comprehensive overview of 2-Methylthioadenosine triphosphate (**2-MeS-ATP**) as a P2Y receptor agonist. It is designed to be a core resource for researchers, scientists, and professionals involved in drug development, offering detailed data, experimental methodologies, and visual representations of key biological processes.

Introduction to 2-MeS-ATP and P2Y Receptors

P2Y receptors are a family of G protein-coupled receptors (GPCRs) activated by extracellular nucleotides, playing crucial roles in a myriad of physiological processes.^[1] **2-MeS-ATP** is a stable and potent analog of adenosine triphosphate (ATP) that has been instrumental in the characterization of various P2Y receptor subtypes. While its diphosphate counterpart, 2-MeS-ADP, is a more selective and often more potent agonist at certain P2Y receptors like P2Y1, P2Y12, and P2Y13, **2-MeS-ATP** exhibits a distinct pharmacological profile, acting as an agonist at several P2Y and even some P2X receptors.^{[2][3][4][5]} This guide will focus on the activity of **2-MeS-ATP** as a P2Y receptor agonist, detailing its potency, selectivity, and the signaling cascades it initiates.

Quantitative Data: Potency and Selectivity of 2-MeS-ATP

The potency of **2-MeS-ATP** varies across different P2Y receptor subtypes. The following tables summarize the half-maximal effective concentration (EC50) and binding affinity (Ki) values for **2-MeS-ATP** at several human P2Y receptors. These values are critical for designing experiments and interpreting results in the context of P2Y receptor pharmacology.

Table 1: Potency (EC50) of **2-MeS-ATP** at Human P2Y Receptors

Receptor Subtype	G-Protein Coupling	2-MeS-ATP EC50 (nM)	Reference
P2Y1	Gq	8	[3]
P2Y11	Gs/Gq	13,800	[3]
P2Y13	Gi	Weak agonist	[6]

Table 2: Comparative Potency of 2-MeS Nucleotide Analogs at ADP-sensitive P2Y Receptors

Receptor Subtype	Agonist	EC50 (nM)	Reference
Human P2Y1	2-MeS-ADP	3	[3]
Human P2Y12	2-MeS-ADP	1 (rat)	[3]
Human P2Y13	2-MeS-ADP	1	[3]

Note: Data is compiled from various sources and experimental conditions may differ.

Signaling Pathways Activated by 2-MeS-ATP

Activation of P2Y receptors by **2-MeS-ATP** initiates distinct downstream signaling cascades depending on the receptor subtype and its associated G-protein.

P2Y1 Receptor Signaling

The P2Y1 receptor predominantly couples to Gq/11 proteins.[7] Agonist binding, including by **2-MeS-ATP**, leads to the activation of phospholipase C (PLC), which in turn hydrolyzes phosphatidylinositol 4,5-bisphosphate (PIP2) into inositol 1,4,5-trisphosphate (IP3) and diacylglycerol (DAG). IP3 triggers the release of intracellular calcium (Ca²⁺) from the endoplasmic reticulum, while DAG activates protein kinase C (PKC).

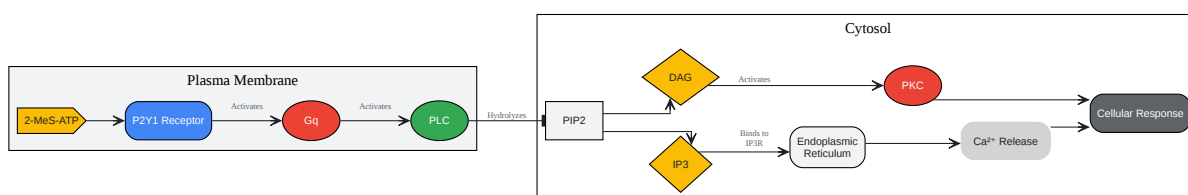

[Click to download full resolution via product page](#)

P2Y1 Receptor Signaling Pathway

P2Y11 Receptor Signaling

The P2Y11 receptor is unique in that it can couple to both Gs and Gq proteins.[7] Coupling to Gs stimulates adenylyl cyclase (AC), leading to an increase in intracellular cyclic AMP (cAMP) levels and subsequent activation of protein kinase A (PKA). The Gq-mediated pathway is similar to that of the P2Y1 receptor.

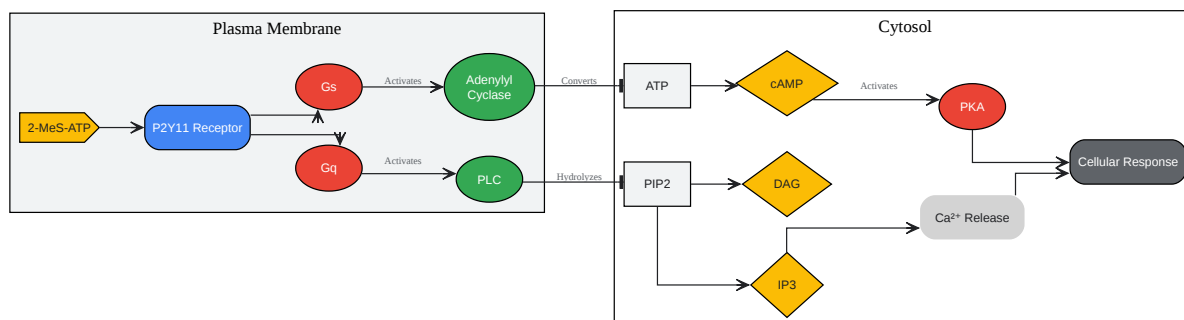

[Click to download full resolution via product page](#)

P2Y11 Receptor Signaling Pathways

P2Y12 and P2Y13 Receptor Signaling

P2Y12 and P2Y13 receptors are coupled to Gi proteins.[7] Activation of these receptors by agonists like 2-MeS-ADP (and weakly by **2-MeS-ATP** at P2Y13) leads to the inhibition of adenylyl cyclase, resulting in decreased intracellular cAMP levels. This pathway is crucial in processes such as platelet aggregation.

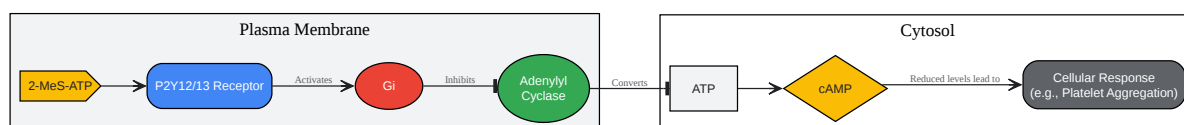

[Click to download full resolution via product page](#)

P2Y12/13 Receptor Signaling Pathway

Experimental Protocols

Detailed methodologies are essential for the accurate assessment of **2-MeS-ATP**'s activity at P2Y receptors. The following are generalized protocols for key in vitro assays.

Radioligand Binding Assay

This assay measures the affinity of **2-MeS-ATP** for a specific P2Y receptor by competing with a radiolabeled ligand.

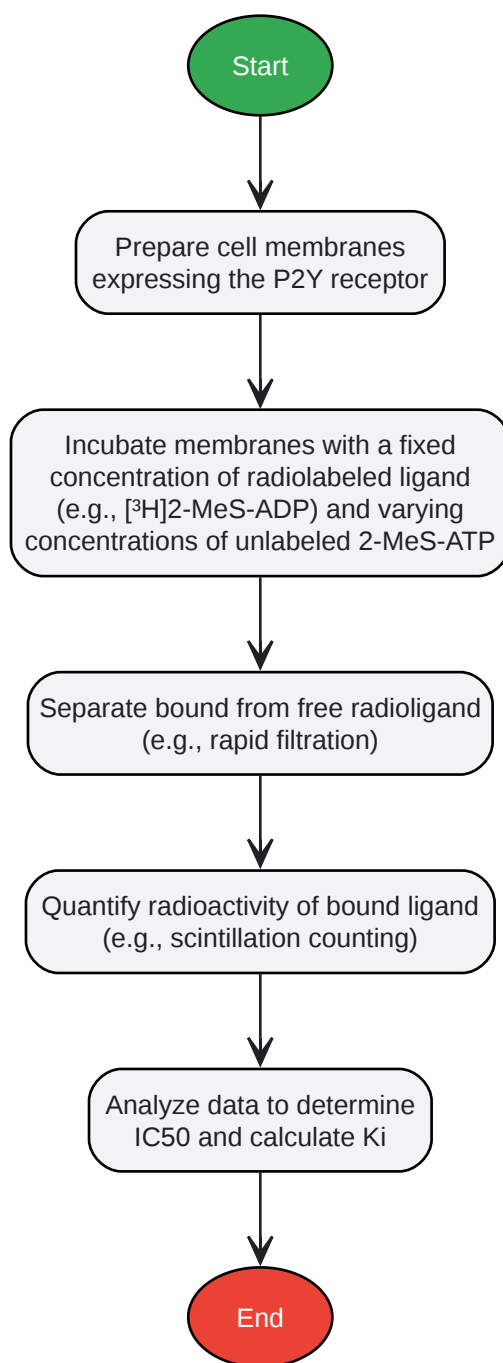

[Click to download full resolution via product page](#)

Radioligand Binding Assay Workflow

Methodology:

- Membrane Preparation: Homogenize cells or tissues expressing the P2Y receptor of interest in a suitable buffer and prepare a membrane fraction by centrifugation.

- Incubation: In a multi-well plate, incubate the membrane preparation with a constant concentration of a suitable radioligand (e.g., [³H]2-MeS-ADP for P2Y1 or P2Y12) and a range of concentrations of unlabeled **2-MeS-ATP**. Include control wells for total binding (radioligand only) and non-specific binding (radioligand plus a high concentration of a known P2Y agonist).
- Separation: After incubation to equilibrium, rapidly separate the membrane-bound radioligand from the free radioligand by vacuum filtration through glass fiber filters.
- Quantification: Wash the filters with ice-cold buffer to remove unbound radioligand. Measure the radioactivity retained on the filters using a scintillation counter.
- Data Analysis: Plot the percentage of specific binding against the concentration of **2-MeS-ATP**. Fit the data to a sigmoidal dose-response curve to determine the IC₅₀ value. Calculate the inhibition constant (K_i) using the Cheng-Prusoff equation.

Calcium Mobilization Assay

This functional assay measures the increase in intracellular calcium concentration following the activation of Gq-coupled P2Y receptors, such as P2Y1, by **2-MeS-ATP**.

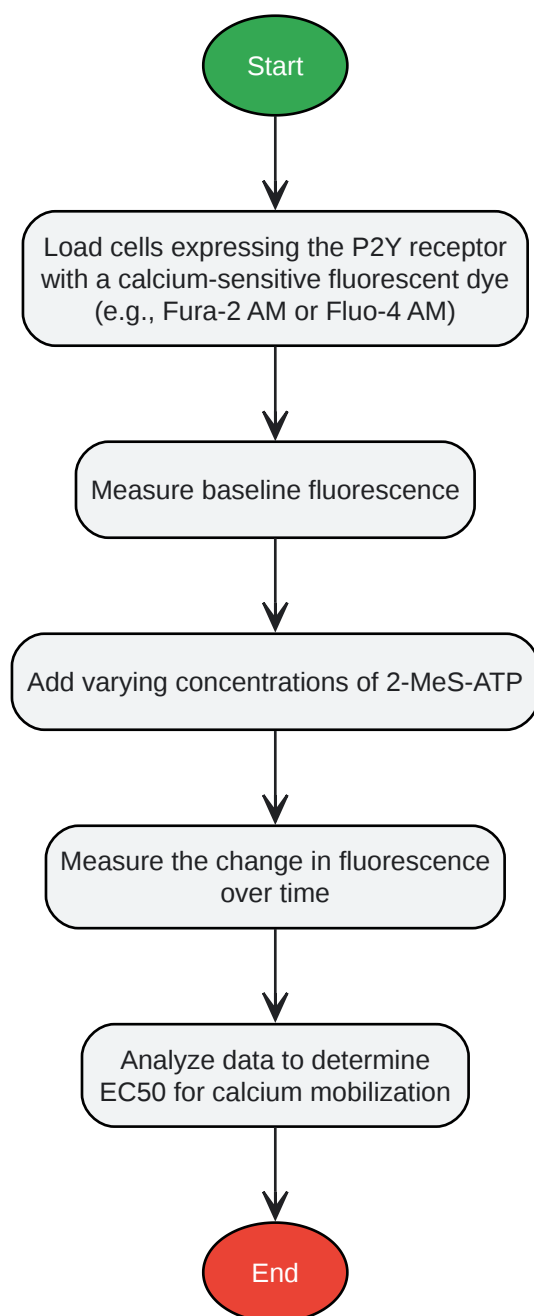

[Click to download full resolution via product page](#)

Calcium Mobilization Assay Workflow

Methodology:

- **Cell Culture and Dye Loading:** Culture cells expressing the Gq-coupled P2Y receptor of interest in a multi-well plate. Load the cells with a calcium-sensitive fluorescent indicator (e.g., Fura-2 AM or Fluo-4 AM) according to the manufacturer's protocol.

- **Baseline Measurement:** Measure the baseline fluorescence of the cells using a fluorescence plate reader.
- **Agonist Addition:** Add varying concentrations of **2-MeS-ATP** to the wells.
- **Response Measurement:** Immediately after agonist addition, monitor the change in fluorescence intensity over time.
- **Data Analysis:** Determine the peak fluorescence response for each concentration of **2-MeS-ATP**. Plot the response against the agonist concentration and fit the data to a dose-response curve to determine the EC50 value.

Adenylyl Cyclase Inhibition Assay

This assay is used to assess the activity of **2-MeS-ATP** at Gi-coupled P2Y receptors, such as P2Y12 and P2Y13, by measuring the inhibition of cAMP production.

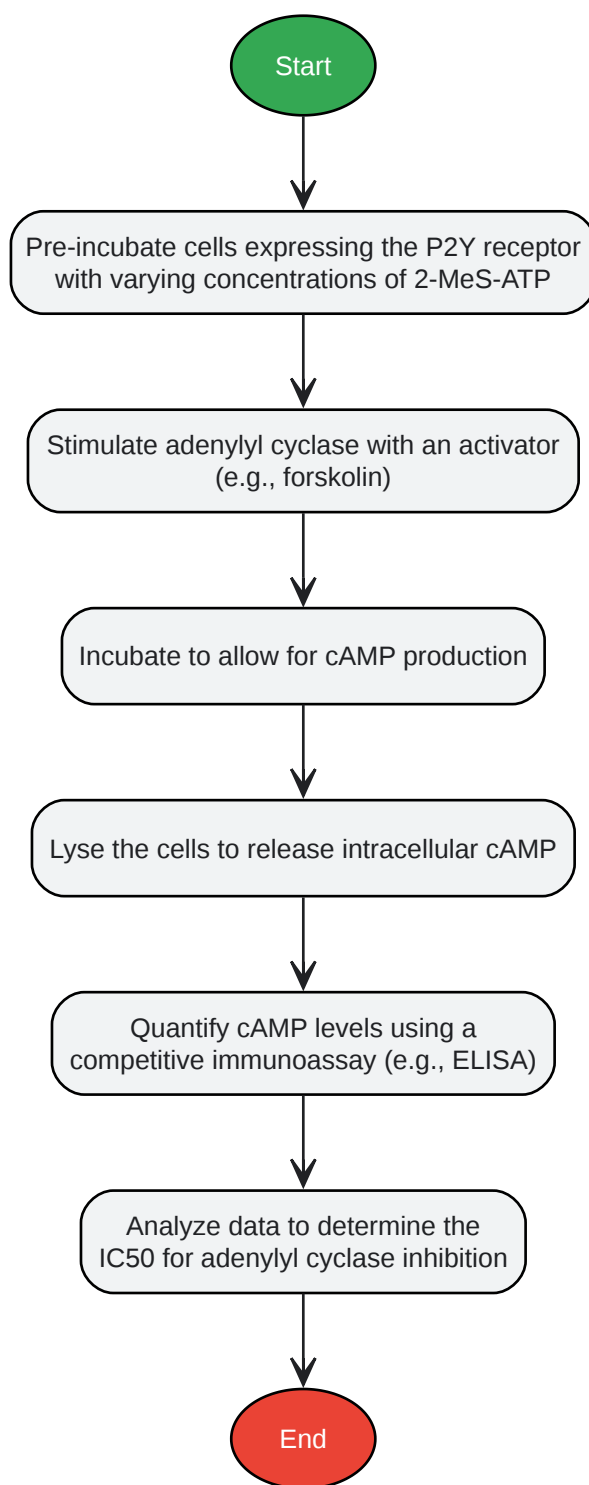

[Click to download full resolution via product page](#)

Adenylyl Cyclase Inhibition Assay Workflow

Methodology:

- Cell Culture: Culture cells expressing the Gi-coupled P2Y receptor of interest.
- Pre-incubation: Pre-incubate the cells with varying concentrations of **2-MeS-ATP**.
- Adenylyl Cyclase Stimulation: Stimulate adenylyl cyclase with an activator, such as forskolin, in the presence of a phosphodiesterase inhibitor to prevent cAMP degradation.
- Incubation: Incubate the cells for a defined period to allow for cAMP accumulation.
- Cell Lysis and cAMP Quantification: Terminate the reaction and lyse the cells. Measure the intracellular cAMP concentration using a commercially available kit, such as an enzyme-linked immunosorbent assay (ELISA).
- Data Analysis: Plot the percentage of inhibition of forskolin-stimulated cAMP production against the concentration of **2-MeS-ATP**. Fit the data to a dose-response curve to determine the IC50 value.

Conclusion

2-MeS-ATP is a valuable pharmacological tool for the study of P2Y receptors. Its distinct profile as an agonist at multiple subtypes, including P2Y1 and P2Y11, allows for the elucidation of their roles in various physiological and pathophysiological processes. This guide provides a foundational resource for researchers, offering quantitative data, detailed signaling pathways, and standardized experimental protocols to facilitate further investigation into the complex world of purinergic signaling. The provided methodologies and data should be adapted and validated for specific experimental systems.

Need Custom Synthesis?

BenchChem offers custom synthesis for rare earth carbides and specific isotopic labeling.

Email: info@benchchem.com or [Request Quote Online](#).

References

- 1. P2受体 : P2Y G蛋白家族概述 [[sigmaaldrich.com](https://www.sigmaaldrich.com)]

- [2. Development of selective agonists and antagonists of P2Y receptors - PMC](#)
[pmc.ncbi.nlm.nih.gov]
- [3. resources.tocris.com](#) [resources.tocris.com]
- [4. Radioligand binding methods: practical guide and tips - PubMed](#)
[pubmed.ncbi.nlm.nih.gov]
- [5. Characterization of Potency of the P2Y13 Receptor Agonists: A Meta-Analysis - PMC](#)
[pmc.ncbi.nlm.nih.gov]
- [6. Coupling of P2Y receptors to G proteins and other signaling pathways - PMC](#)
[pmc.ncbi.nlm.nih.gov]
- [7. Evidence that 2-methylthioATP and 2-methylthioADP are both agonists at the rat hepatocyte P2Y1 receptor - PMC](#) [pmc.ncbi.nlm.nih.gov]
- To cite this document: BenchChem. [2-MeS-ATP as a P2Y Receptor Agonist: A Technical Guide]. BenchChem, [2026]. [Online PDF]. Available at:
[<https://www.benchchem.com/product/b15571884/docs#2-mes-atp-as-a-p2y-receptor-agonist-a-technical-guide>]

Disclaimer & Data Validity:

The information provided in this document is for Research Use Only (RUO) and is strictly not intended for diagnostic or therapeutic procedures. While BenchChem strives to provide accurate protocols, we make no warranties, express or implied, regarding the fitness of this product for every specific experimental setup.

Technical Support: The protocols provided are for reference purposes. Unsure if this reagent suits your experiment?

Need Industrial/Bulk Grade? [Request Custom Synthesis Quote](#)

BenchChem

Our mission is to be the trusted global source of essential and advanced chemicals, empowering scientists and researchers to drive progress in science and industry.

Contact

Address: 3281 E Guasti Rd

Ontario, CA 91761, United States

Phone: (601) 213-4426

Email: info@benchchem.com

Contact our Ph.D. Support Team for a compatibility check