

# Application Notes and Protocols for Measuring DNMT1 Inhibition by DC\_517

**Author:** BenchChem Technical Support Team. **Date:** April 2026

## Compound of Interest

Compound Name: DC\_517  
Cat. No.: B15570699

[Get Quote](#)

Audience: Researchers, scientists, and drug development professionals.

Introduction: DNA methylation is a critical epigenetic modification that plays a vital role in regulating gene expression, genomic stability, and cell differentiation.[1][2] This process is catalyzed by DNA methyltransferases (DNMTs), which transfer a methyl group from S-adenosyl-L-methionine (SAM) to the C5 position of cytosine.[3] DNA Methyltransferase 1 (DNMT1) is the primary enzyme responsible for maintaining existing DNA methylation patterns following DNA replication, making it a crucial target in various diseases, particularly cancer, where aberrant hypermethylation can silence tumor suppressor genes.[1][4][5]

**DC\_517** is a non-nucleoside small molecule identified as a potent and selective inhibitor of DNMT1.[6][7][8] Unlike nucleoside analogs that require incorporation into DNA, non-nucleoside inhibitors like **DC\_517** directly interact with the enzyme, offering a different modality for therapeutic intervention.[7][9] These application notes provide detailed protocols for researchers to quantitatively assess the inhibitory effects of **DC\_517** on DNMT1, both in biochemical and cellular contexts.

## Quantitative Data Summary for DC\_517

The following table summarizes the reported biochemical potency of **DC\_517** against human DNMT1.

Parameter	Value	Reference
IC50	1.7 $\mu$ M	[6][8][10]
Kd	0.91 $\mu$ M	[6][8][10]

## Mechanism of DNMT1 Inhibition by DC\_517

DNMT1 maintains the methylation landscape by recognizing hemi-methylated CpG sites on newly synthesized DNA strands.[4] The enzyme flips the target cytosine out of the DNA helix and into its catalytic pocket, where it facilitates the transfer of a methyl group from the cofactor SAM.[5][8] As a non-nucleoside inhibitor, **DC\_517** is believed to directly interfere with this process, likely by binding to the enzyme and preventing catalysis.[7][9]

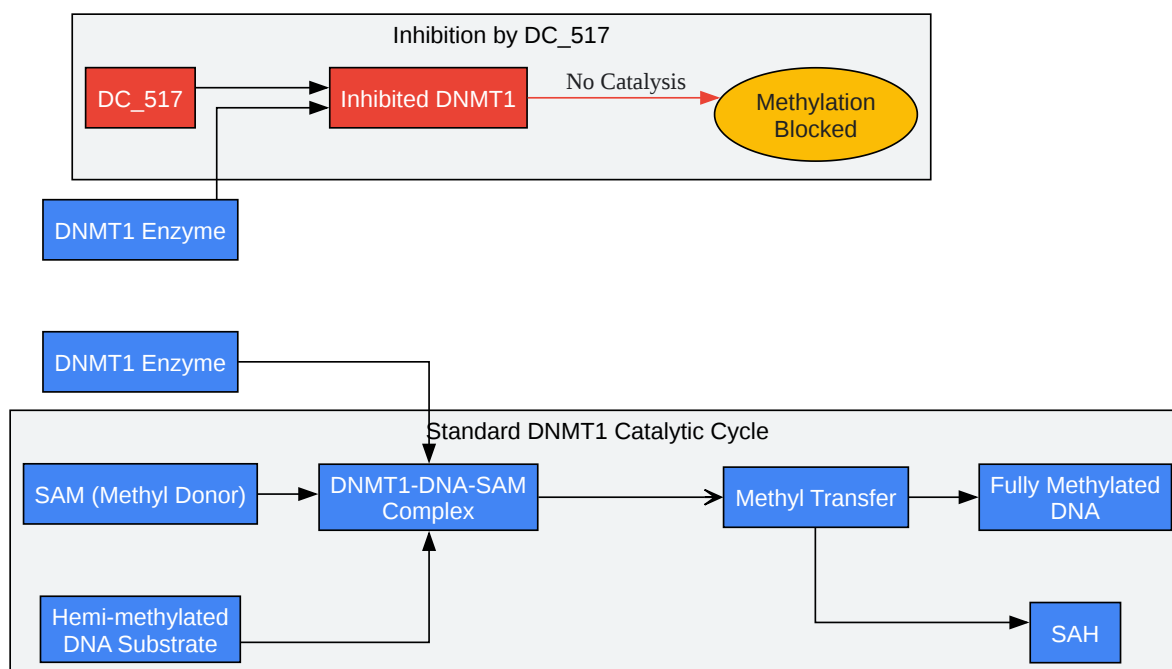

[Click to download full resolution via product page](#)

**Caption:** Mechanism of DNMT1 inhibition by **DC\_517**.

## Experimental Protocols

This section details key biochemical and cellular assays to measure the inhibitory activity of **DC\_517**.

### Protocol 1: In Vitro DNMT1 Inhibitor Screening Assay (ELISA-based)

This protocol describes a non-radioactive, ELISA-based method to determine the IC<sub>50</sub> value of **DC\_517** by measuring its effect on the activity of purified recombinant DNMT1 enzyme.

Commercially available kits from suppliers like EpigenTek or Abcam can be used for this purpose.[\[11\]](#)[\[12\]](#)[\[13\]](#)

Principle: A cytosine-rich DNA substrate is immobilized on microplate wells. Recombinant DNMT1, in the presence of the methyl donor SAM, methylates the DNA. The extent of methylation is quantified using a specific antibody for 5-methylcytosine (5-mC), followed by a colorimetric or fluorometric readout. The signal intensity is inversely proportional to the DNMT1 inhibition by **DC\_517**.[\[11\]](#)[\[14\]](#)

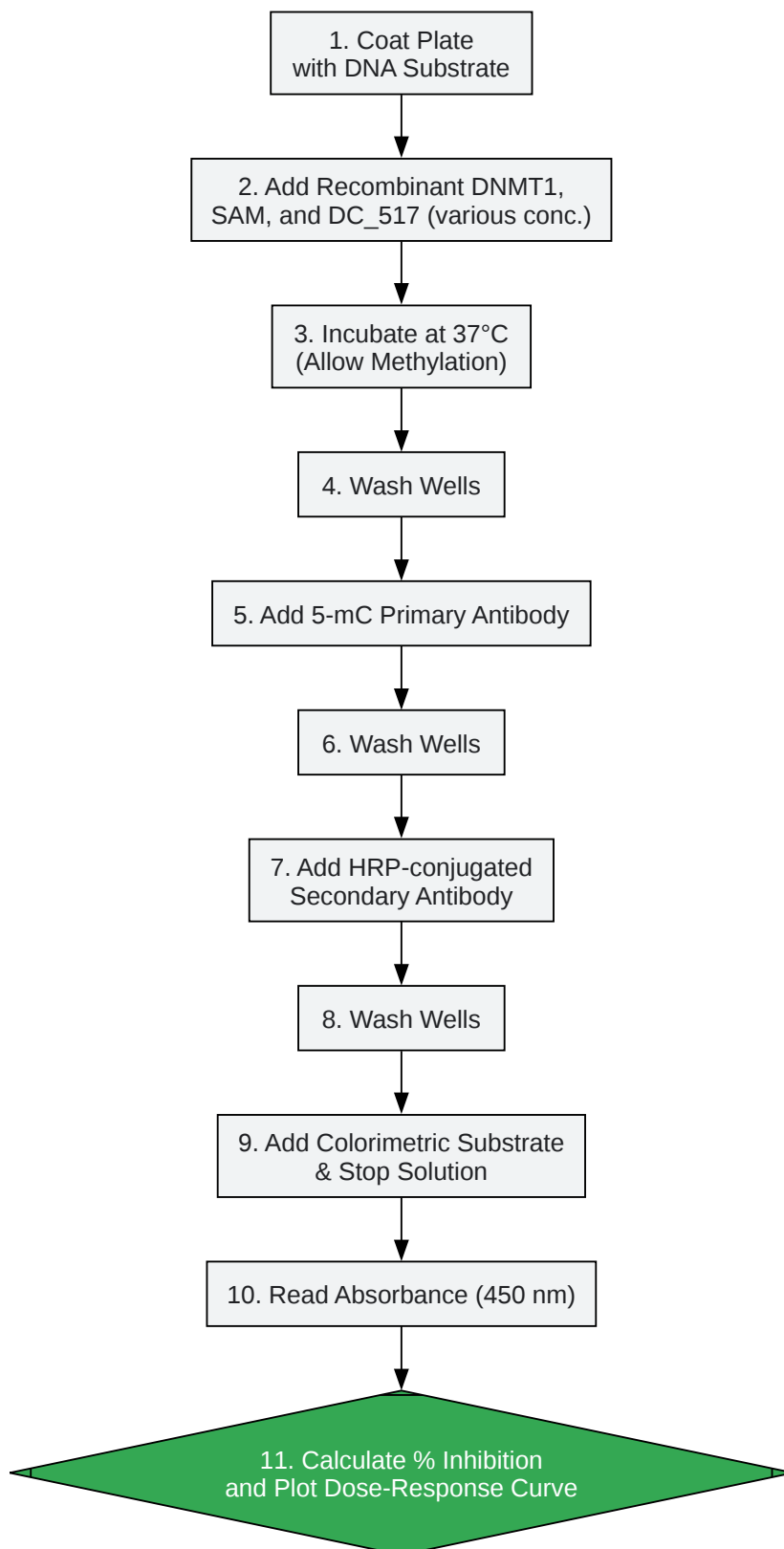

[Click to download full resolution via product page](#)

**Caption:** Experimental workflow for the ELISA-based DNMT1 inhibition assay.

#### Methodology:

- Preparation: Prepare serial dilutions of **DC\_517** in the DNMT assay buffer. A typical concentration range might be 0.01  $\mu\text{M}$  to 100  $\mu\text{M}$ .
- Reaction Setup: To the DNA-coated wells, add the assay buffer, diluted SAM, purified DNMT1 enzyme, and the **DC\_517** dilutions.[12] Include "no inhibitor" controls (for 100% activity) and "no enzyme" blank controls.
- Enzymatic Reaction: Cover the plate and incubate at 37°C for 60-90 minutes to allow the methylation reaction to proceed.[12]
- Antibody Incubation: Wash the wells with the provided wash buffer. Add the diluted capture antibody (anti-5-mC) to each well and incubate at room temperature for 60 minutes.[12]
- Secondary Antibody: Aspirate and wash the wells again. Add the diluted detection antibody (e.g., HRP-conjugated secondary antibody) and incubate at room temperature for 30 minutes.[12]
- Signal Development: After a final wash, add the developing solution and incubate in the dark until color develops (typically 2-10 minutes). Add the stop solution.[12]
- Data Acquisition: Read the absorbance on a microplate reader at 450 nm.

#### Data Analysis:

- Subtract the average absorbance of the blank control from all other readings.
- Calculate the percentage of DNMT1 inhibition for each **DC\_517** concentration using the formula: % Inhibition =  $[1 - (\text{OD}_{\text{inhibitor}} / \text{OD}_{\text{no\_inhibitor}})] * 100\%$
- Plot the % Inhibition against the log of the **DC\_517** concentration and fit the data to a sigmoidal dose-response curve to determine the IC50 value.

## Protocol 2: Cellular Global DNA Methylation Assay

This protocol measures the ability of **DC\_517** to reduce total genomic 5-mC levels in a cellular context, confirming its activity in a biological system.

Principle: Cancer cells (e.g., HCT116 colon cancer cells) are treated with **DC\_517**. Genomic DNA is then extracted and the percentage of 5-mC relative to total cytosine is quantified using an ELISA-based method. This provides a measure of the compound's global demethylating activity.

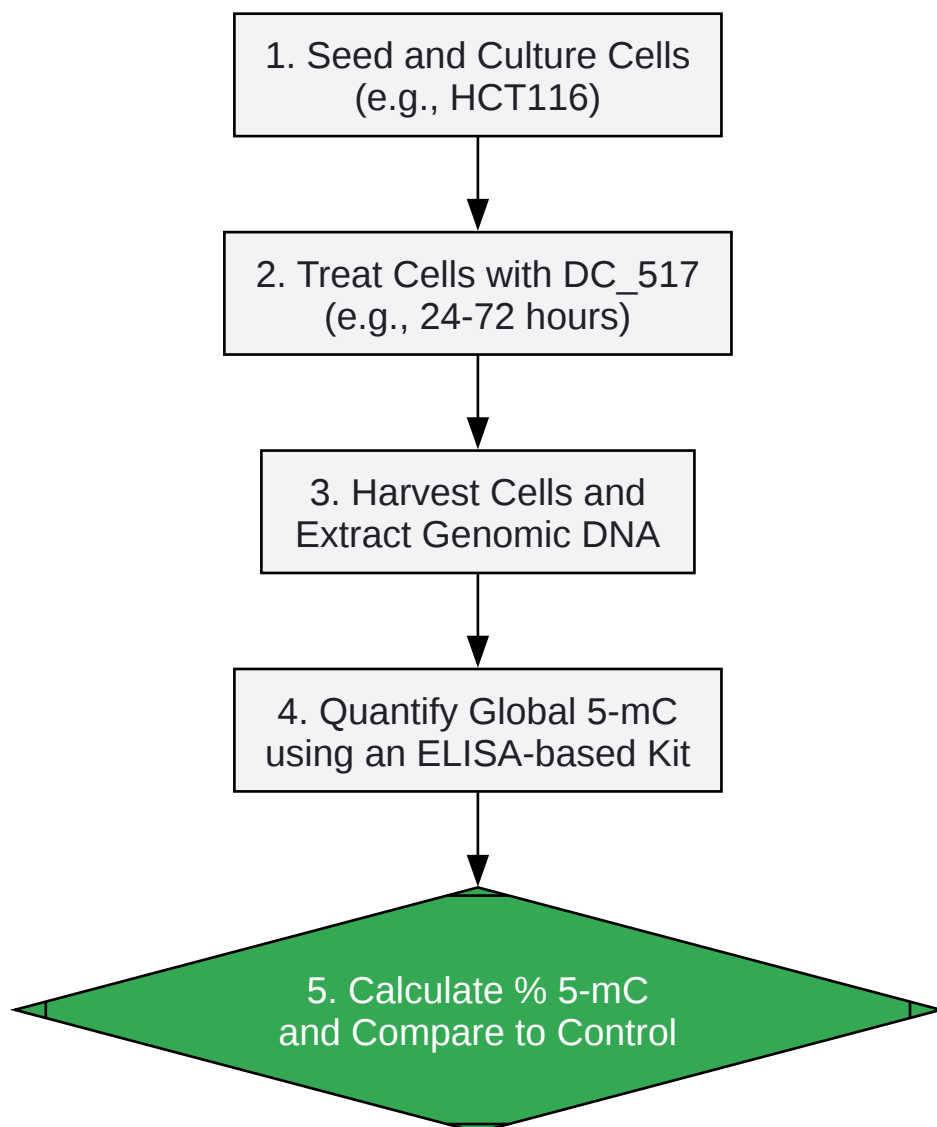

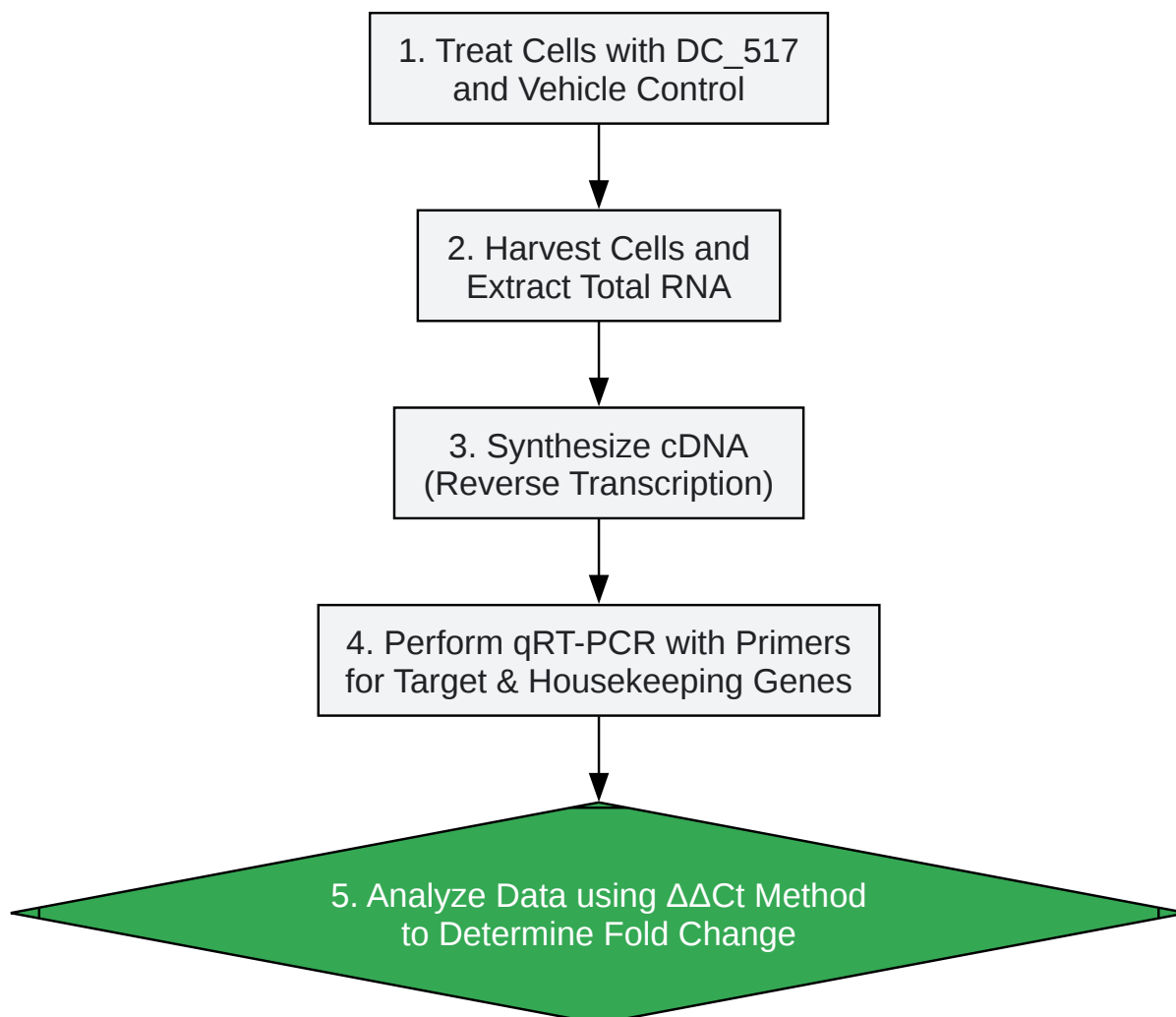

[Click to download full resolution via product page](#)

#### Need Custom Synthesis?

BenchChem offers custom synthesis for rare earth carbides and specific isotopic labeling.

Email: [info@benchchem.com](mailto:info@benchchem.com) or [Request Quote Online](#).

## References

- 1. What are DNMT1 inhibitors and how do they work? [[synapse.patsnap.com](https://synapse.patsnap.com)]

- [2. What are DNA methyltransferase inhibitors and how do they work? \[synapse.patsnap.com\]](#)
- [3. mdpi.com \[mdpi.com\]](#)
- [4. Discovery of a first-in-class reversible DNMT1-selective inhibitor with improved tolerability and efficacy in acute myeloid leukemia - PMC \[pmc.ncbi.nlm.nih.gov\]](#)
- [5. Molecular Modeling of Inhibitors of Human DNA Methyltransferase with a Crystal Structure: Discovery of a Novel DNMT1 Inhibitor - PMC \[pmc.ncbi.nlm.nih.gov\]](#)
- [6. file.medchemexpress.com \[file.medchemexpress.com\]](#)
- [7. tandfonline.com \[tandfonline.com\]](#)
- [8. Recent progress in DNA methyltransferase inhibitors as anticancer agents - PMC \[pmc.ncbi.nlm.nih.gov\]](#)
- [9. researchgate.net \[researchgate.net\]](#)
- [10. medchemexpress.com \[medchemexpress.com\]](#)
- [11. EpiQuik DNMT1 Activity/Inhibitor Screening Assay Core Kit | EpigenTek \[epigentek.com\]](#)
- [12. abcam.com \[abcam.com\]](#)
- [13. DNMT1 Inhibitor Screening Assay Kit, Research Kits - CD BioSciences \[epigenhub.com\]](#)
- [14. EpiQuik DNMT Activity/Inhibition Assay Ultra Kit \(Colorimetric\) | EpigenTek \[epigentek.com\]](#)
- [To cite this document: BenchChem. \[Application Notes and Protocols for Measuring DNMT1 Inhibition by DC\\_517\]. BenchChem, \[2026\]. \[Online PDF\]. Available at: \[https://www.benchchem.com/product/b15570699/docs#application-notes-and-protocols-for-measuring-dnmt1-inhibition-by-dc-517\]](#)

---

### Disclaimer & Data Validity:

The information provided in this document is for Research Use Only (RUO) and is strictly not intended for diagnostic or therapeutic procedures. While BenchChem strives to provide accurate protocols, we make no warranties, express or implied, regarding the fitness of this product for every specific experimental setup.

**Technical Support:** The protocols provided are for reference purposes. Unsure if this reagent suits your experiment?

**Need Industrial/Bulk Grade?** [Request Custom Synthesis Quote](#)

## BenchChem

Our mission is to be the trusted global source of essential and advanced chemicals, empowering scientists and researchers to drive progress in science and industry.

### Contact

Address: 3281 E Guasti Rd  
Ontario, CA 91761, United States  
Phone: (601) 213-4426  
Email: [info@benchchem.com](mailto:info@benchchem.com)

[Contact our Ph.D. Support Team for a compatibility check](#)