

# Technical Support Center: Method Refinement for Consistent Penipanoid C Bioactivity

**Author:** BenchChem Technical Support Team. **Date:** April 2026

## Compound of Interest

Compound Name: Penipanoid C

Cat. No.: B15569164

[Get Quote](#)

This technical support center provides troubleshooting guides and frequently asked questions (FAQs) to assist researchers, scientists, and drug development professionals in achieving consistent and reliable results in bioactivity studies of **Penipanoid C**.

## Frequently Asked Questions (FAQs)

Q1: What is **Penipanoid C** and what are its known bioactivities?

**Penipanoid C** is a quinazolinone alkaloid originally isolated from the marine sediment-derived fungus, *Penicillium paneum*.<sup>[1]</sup> It has demonstrated cytotoxic activity against a range of human cancer cell lines, including hepatocellular carcinoma (HepG2, Bel-7402), lung carcinoma (A549), and glioblastoma (U251).<sup>[2]</sup> Its anticancer effects are attributed to the inhibition of cell proliferation and the induction of apoptosis.<sup>[2]</sup>

Q2: What is the general mechanism of action for **Penipanoid C**'s cytotoxic effects?

Studies on **Penipanoid C** and its derivatives suggest that its mechanism of action involves:

- Cell Cycle Arrest: It can halt the progression of the cell cycle, preventing cancer cells from dividing and proliferating.<sup>[2]</sup>

- Induction of Apoptosis: It triggers programmed cell death in cancer cells.[2]
- Generation of Reactive Oxygen Species (ROS): An increase in ROS levels within cancer cells can lead to cellular damage and apoptosis.[2]

Q3: What is a suitable solvent for dissolving **Penipanoid C** for in vitro assays?

Dimethyl sulfoxide (DMSO) is a commonly used solvent for dissolving quinazolinone derivatives for biological assays.[3][4] It is recommended to prepare a high-concentration stock solution in DMSO and then dilute it to the final desired concentration in the cell culture medium.

Q4: What are the key considerations for ensuring the stability of **Penipanoid C** in solution?

To maintain the stability of **Penipanoid C** in a DMSO stock solution, it is advisable to:

- Store the stock solution at -20°C or -80°C for long-term storage.
- Prepare fresh dilutions in culture media for each experiment.
- Avoid repeated freeze-thaw cycles of the stock solution by aliquoting it into smaller volumes.

## Troubleshooting Guides

### Issue 1: Inconsistent or No Cytotoxic Effect Observed

Question: My MTT assay results show high variability between replicates or no significant cytotoxic effect of **Penipanoid C**. What could be the issue?

Answer: This can be due to several factors ranging from compound solubility to assay execution. Here are some troubleshooting steps:

Potential Cause	Recommended Solution
Compound Precipitation	Penipanoid C, being a relatively hydrophobic molecule, may precipitate in the aqueous culture medium. Visually inspect the wells for any precipitate. To resolve this, consider: 1. Serial Dilution: Perform a serial dilution of the DMSO stock in pre-warmed (37°C) culture medium rather than adding the stock directly to the wells. [5] 2. Lower Final DMSO Concentration: Ensure the final DMSO concentration in the culture medium is low (typically $\leq 0.5\%$ ) to avoid both solvent toxicity and precipitation.
Cell Seeding Density	Inconsistent cell numbers across wells can lead to high variability. Ensure a homogenous single-cell suspension before seeding and use a calibrated multichannel pipette for plating.
Reagent Issues	The MTT reagent is light-sensitive and can degrade over time. Prepare fresh MTT solution for each experiment and protect it from light. Ensure the solubilization buffer completely dissolves the formazan crystals.
Incorrect Incubation Time	The incubation time with Penipanoid C may be too short to induce a cytotoxic effect. Consider performing a time-course experiment (e.g., 24, 48, 72 hours) to determine the optimal exposure time.

## Issue 2: High Background Signal in Assays

Question: I am observing a high background signal in my fluorescence-based assays (e.g., ROS detection, Annexin V). How can I reduce it?

Answer: High background can mask the true signal from your experimental samples. Here are some common causes and solutions:

Potential Cause	Recommended Solution
Incomplete Washing	Residual unbound fluorescent dye can contribute to high background. Ensure thorough but gentle washing of the cells with PBS or an appropriate buffer between staining steps.
Autofluorescence of the Compound	Some compounds can exhibit intrinsic fluorescence. Run a control with Penipanoid C in cell-free medium to check for autofluorescence at the excitation/emission wavelengths of your dye.
Phenol Red in Media	Phenol red in cell culture media can interfere with some fluorescent assays. Use phenol red-free media for the duration of the staining and measurement steps.
Contamination	Microbial contamination (bacteria, yeast, mycoplasma) can lead to spurious signals. Regularly check your cell cultures for contamination.

## Experimental Protocols

### Cytotoxicity Assessment using MTT Assay

This protocol is for determining the cytotoxic effect of **Penipanoid C** on cancer cell lines like HepG2.

Materials:

- **Penipanoid C**
- HepG2 cells
- DMEM (Dulbecco's Modified Eagle Medium) with 10% FBS (Fetal Bovine Serum)
- 96-well cell culture plates

- MTT (3-(4,5-dimethylthiazol-2-yl)-2,5-diphenyltetrazolium bromide) solution (5 mg/mL in PBS)
- DMSO
- Microplate reader

#### Procedure:

- **Cell Seeding:** Seed HepG2 cells into a 96-well plate at a density of  $5 \times 10^3$  cells/well in 100  $\mu$ L of DMEM with 10% FBS. Incubate for 24 hours at 37°C in a 5% CO<sub>2</sub> humidified atmosphere.
- **Compound Treatment:** Prepare a stock solution of **Penipanoid C** in DMSO. On the day of the experiment, prepare serial dilutions of **Penipanoid C** in DMEM. Remove the old medium from the wells and add 100  $\mu$ L of the diluted compound solutions. Include a vehicle control (medium with the same final concentration of DMSO as the highest **Penipanoid C** concentration).
- **Incubation:** Incubate the plate for 48 hours at 37°C and 5% CO<sub>2</sub>.
- **MTT Addition:** After incubation, add 20  $\mu$ L of MTT solution (5 mg/mL) to each well and incubate for another 4 hours.
- **Formazan Solubilization:** Carefully remove the medium and add 150  $\mu$ L of DMSO to each well to dissolve the formazan crystals. Gently shake the plate for 10 minutes.
- **Absorbance Measurement:** Measure the absorbance at 570 nm using a microplate reader.
- **Data Analysis:** Calculate the percentage of cell viability for each concentration relative to the vehicle control.

#### Data Presentation:

Penipanoid C ( $\mu\text{M}$ )	Absorbance (570 nm) (Mean $\pm$ SD)	% Cell Viability
0 (Vehicle Control)	1.25 $\pm$ 0.08	100
0.1	1.18 $\pm$ 0.07	94.4
1	0.95 $\pm$ 0.06	76.0
5	0.63 $\pm$ 0.04	50.4
10	0.31 $\pm$ 0.03	24.8
25	0.15 $\pm$ 0.02	12.0
50	0.08 $\pm$ 0.01	6.4

## Cell Cycle Analysis by Flow Cytometry

This protocol outlines the procedure for analyzing the effect of **Penipanoid C** on the cell cycle distribution using propidium iodide (PI) staining.

Materials:

- **Penipanoid C**-treated and control cells
- PBS (Phosphate-Buffered Saline)
- 70% Ethanol (ice-cold)
- RNase A (100  $\mu\text{g}/\text{mL}$ )
- Propidium Iodide (PI) staining solution (50  $\mu\text{g}/\text{mL}$ )
- Flow cytometer

Procedure:

- **Cell Treatment and Harvesting:** Treat cells with **Penipanoid C** for the desired time. Harvest both floating and adherent cells by trypsinization.

- **Washing:** Wash the cells twice with ice-cold PBS by centrifugation at 300 x g for 5 minutes.
- **Fixation:** Resuspend the cell pellet in 500  $\mu$ L of PBS. While gently vortexing, add 4.5 mL of ice-cold 70% ethanol dropwise to fix the cells. Incubate at -20°C for at least 2 hours.[6]
- **Staining:** Centrifuge the fixed cells, discard the ethanol, and wash the pellet with PBS. Resuspend the cell pellet in 1 mL of PI staining solution containing RNase A.
- **Incubation:** Incubate the cells in the staining solution for 30 minutes at room temperature in the dark.[6]
- **Flow Cytometry Analysis:** Analyze the samples on a flow cytometer. Use appropriate software to deconvolute the DNA content histograms and determine the percentage of cells in G0/G1, S, and G2/M phases of the cell cycle.

## Apoptosis Detection by Annexin V-FITC and PI Staining

This protocol describes how to quantify apoptosis induced by **Penipanoid C** using an Annexin V-FITC/PI dual staining assay.

### Materials:

- Annexin V-FITC Apoptosis Detection Kit (containing Annexin V-FITC, Propidium Iodide, and Binding Buffer)
- **Penipanoid C**-treated and control cells
- PBS
- Flow cytometer

### Procedure:

- **Cell Treatment and Harvesting:** Treat cells with **Penipanoid C**. Harvest all cells (adherent and floating).
- **Washing:** Wash the cells twice with cold PBS.

- Resuspension: Resuspend the cells in 1X Binding Buffer at a concentration of  $1 \times 10^6$  cells/mL.
- Staining: Transfer 100  $\mu$ L of the cell suspension ( $1 \times 10^5$  cells) to a flow cytometry tube. Add 5  $\mu$ L of Annexin V-FITC and 5  $\mu$ L of PI.
- Incubation: Gently vortex the cells and incubate for 15 minutes at room temperature in the dark.[7]
- Analysis: Add 400  $\mu$ L of 1X Binding Buffer to each tube and analyze by flow cytometry within one hour.

## Measurement of Intracellular ROS using DCFH-DA

This protocol is for measuring the generation of intracellular reactive oxygen species (ROS) using the fluorescent probe 2',7'-dichlorodihydrofluorescein diacetate (DCFH-DA).

Materials:

- **Penipanoid C**-treated and control cells
- DCFH-DA (5 mM stock in DMSO)
- Serum-free medium
- PBS
- Fluorescence microplate reader or flow cytometer

Procedure:

- Cell Treatment: Treat cells with **Penipanoid C** in a 96-well plate or other suitable culture vessel.
- DCFH-DA Loading: After treatment, remove the medium and wash the cells once with PBS. Add 100  $\mu$ L of serum-free medium containing 10  $\mu$ M DCFH-DA to each well.
- Incubation: Incubate the plate at 37°C for 30 minutes in the dark.[8]

- Washing: Remove the DCFH-DA solution and wash the cells twice with PBS.
- Measurement: Add 100  $\mu$ L of PBS to each well. Measure the fluorescence intensity using a fluorescence microplate reader with excitation at 485 nm and emission at 530 nm.[8]

## Visualizations

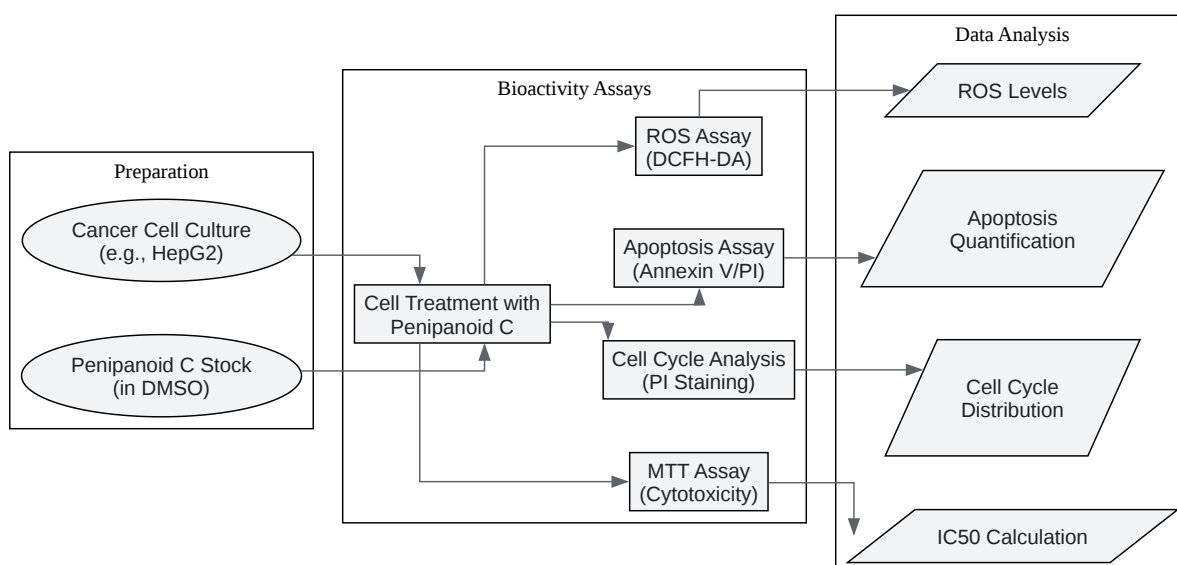

[Click to download full resolution via product page](#)

Experimental workflow for assessing **Penipanoid C** bioactivity.

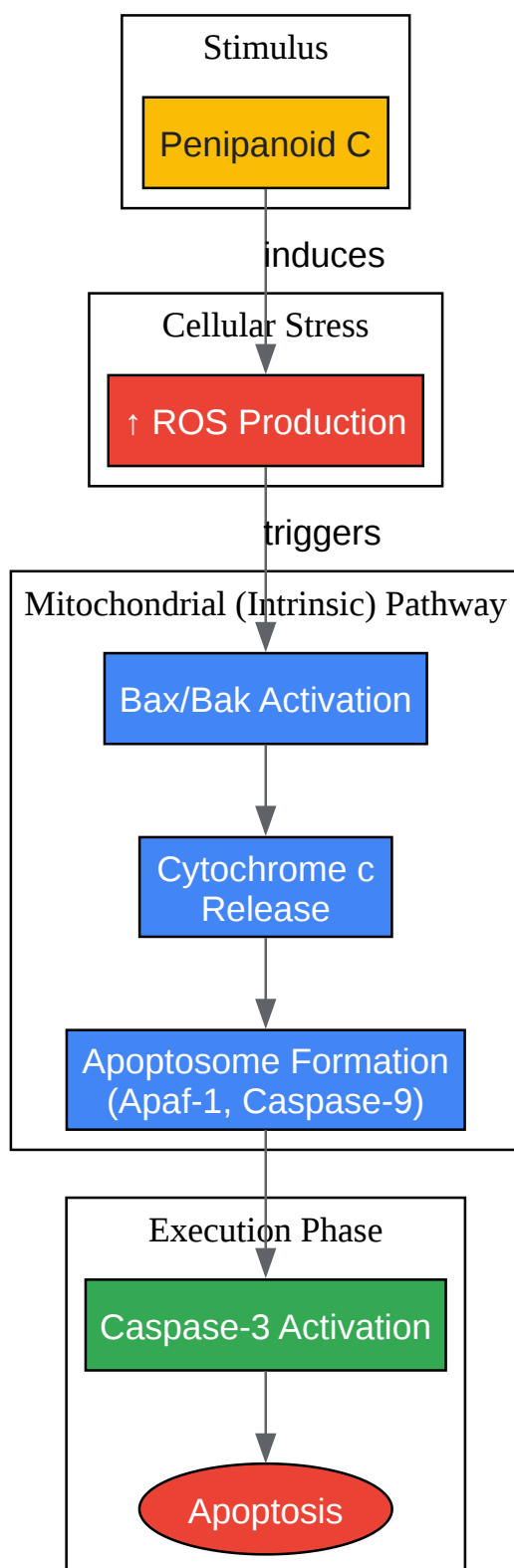

[Click to download full resolution via product page](#)

Simplified intrinsic apoptosis pathway induced by **Penipanoid C**.

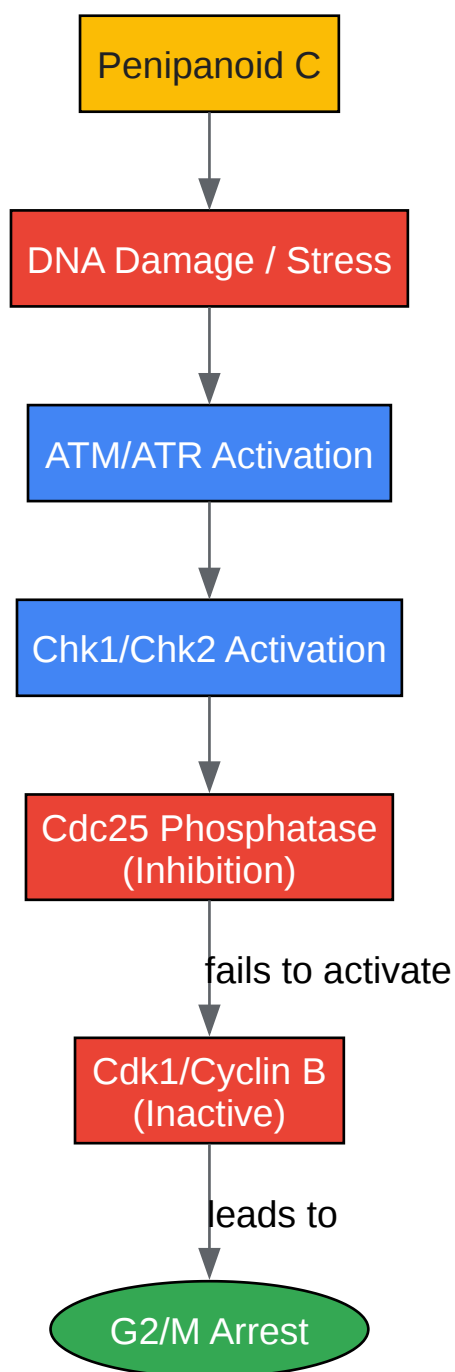

[Click to download full resolution via product page](#)

G2/M cell cycle arrest signaling pathway.

#### ***Need Custom Synthesis?***

*BenchChem offers custom synthesis for rare earth carbides and specific isotopic labeling.*

*Email: [info@benchchem.com](mailto:info@benchchem.com) or [Request Quote Online](#).*

## References

- [1. Activation of apoptosis signalling pathways by reactive oxygen species - PubMed \[pubmed.ncbi.nlm.nih.gov\]](#)
- [2. Protocol for Apoptosis Assay by Flow Cytometry Using Annexin V Staining Method - PMC \[pmc.ncbi.nlm.nih.gov\]](#)
- [3. medchemexpress.com \[medchemexpress.com\]](#)
- [4. cibtech.org \[cibtech.org\]](#)
- [5. benchchem.com \[benchchem.com\]](#)
- [6. DNA Content for Cell Cycle Analysis of Fixed Cells With Propidium Iodide - Flow Cytometry Core Facility \[med.virginia.edu\]](#)
- [7. documents.thermofisher.com \[documents.thermofisher.com\]](#)
- [8. Detection of Total Reactive Oxygen Species in Adherent Cells by 2',7'-Dichlorodihydrofluorescein Diacetate Staining - PMC \[pmc.ncbi.nlm.nih.gov\]](#)
- To cite this document: BenchChem. [Technical Support Center: Method Refinement for Consistent Penipanoid C Bioactivity]. BenchChem, [2026]. [Online PDF]. Available at: [<https://www.benchchem.com/product/b15569164/docs#technical-support-center-method-refinement-for-consistent-penipanoid-c-bioactivity>]

---

### Disclaimer & Data Validity:

The information provided in this document is for Research Use Only (RUO) and is strictly not intended for diagnostic or therapeutic procedures. While BenchChem strives to provide accurate protocols, we make no warranties, express or implied, regarding the fitness of this product for every specific experimental setup.

**Technical Support:** The protocols provided are for reference purposes. Unsure if this reagent suits your experiment?

**Need Industrial/Bulk Grade?** [Request Custom Synthesis Quote](#)

# BenchChem

Our mission is to be the trusted global source of essential and advanced chemicals, empowering scientists and researchers to drive progress in science and industry.

## Contact

Address: 3281 E Guasti Rd

Ontario, CA 91761, United States

Phone: (601) 213-4426

Email: [info@benchchem.com](mailto:info@benchchem.com)

[Contact our Ph.D. Support Team for a compatibility check](#)