

MI-538 stability and storage conditions

Author: BenchChem Technical Support Team. **Date:** April 2026

Compound of Interest

Compound Name: MI-538
Cat. No.: B15569956

[Get Quote](#)

MI-538 Technical Support Center

This technical support center provides researchers, scientists, and drug development professionals with comprehensive guidance on the stability, storage, and handling of **MI-538**.

Frequently Asked Questions (FAQs)

Q1: What is **MI-538**?

MI-538 is a potent and selective small molecule inhibitor of the interaction between menin and Mixed Lineage Leukemia (MLL) fusion proteins.^[1] It binds to menin with a high affinity, disrupting the menin-MLL interaction that is critical for the proliferation of MLL-rearranged leukemia cells.^{[1][2]}

Q2: What is the mechanism of action of **MI-538**?

MI-538 competitively binds to the MLL-binding pocket of menin, preventing the recruitment of the MLL fusion protein. This disruption leads to the downregulation of target genes, such as Hoxa9 and Meis1, which are essential for leukemogenesis.^{[1][3]} Research also suggests that menin-MLL inhibitors like **MI-538** can induce the degradation of menin protein through the ubiquitin-proteasome pathway.

Q3: What are the recommended storage conditions for **MI-538**?

The recommended storage conditions for **MI-538** depend on whether it is in solid form or dissolved in a solvent. Following these guidelines is crucial to ensure the stability and activity of the compound.

Data Summary

MI-538 Storage Conditions

Form	Storage Temperature	Duration	Source
Powder	-20°C	3 years	
	4°C	2 years	
In Solvent	-80°C	6 months - 2 years	
	-20°C	1 month - 1 year	

Note: There are slight variations in the reported stability of **MI-538** in solvent. It is always recommended to consult the certificate of analysis provided by the specific supplier.

MI-538 Physicochemical Properties

Property	Value
Molecular Weight	566.60 g/mol
Formula	C ₂₇ H ₂₅ F ₃ N ₈ OS
CAS Number	1857417-10-7
Appearance	White to off-white solid
Solubility	Soluble in DMSO (100 mg/mL)

Troubleshooting Guide

Issue	Possible Cause	Recommended Solution
Difficulty dissolving MI-538 powder	Improper solvent or technique.	Use newly opened, anhydrous DMSO as MI-538 is hygroscopic. Gentle warming and/or sonication can aid dissolution.
Precipitation of MI-538 in stock solution during storage	Solution is supersaturated or has undergone freeze-thaw cycles.	Ensure the stock solution is not prepared at a concentration exceeding its solubility limit. Aliquot the stock solution into single-use vials to avoid repeated freeze-thaw cycles.
Inconsistent or no biological effect observed in cell-based assays	1. Compound degradation. 2. Incorrect dosage. 3. Cell line not dependent on menin-MLL interaction.	1. Ensure MI-538 has been stored correctly and prepare fresh dilutions from a properly stored stock solution. 2. Perform a dose-response experiment to determine the optimal concentration for your cell line. The reported GI ₅₀ for MLL leukemia cells is 83 nM. 3. Use cell lines with known MLL translocations (e.g., MV4;11, MOLM-13) as positive controls. MI-538 has shown no effect on cell lines without MLL translocations, such as HL-60.
Variability in in vivo experiments	Improper formulation or administration.	For in vivo studies, it is recommended to prepare the working solution fresh on the day of use. A suggested formulation is 10% DMSO, 40% PEG300, 5% Tween-80, and 45% saline.

Experimental Protocols

Preparation of MI-538 Stock Solution (10 mM in DMSO)

- Equilibrate the vial of **MI-538** powder to room temperature before opening.
- Based on the molecular weight of 566.60 g/mol , weigh out the desired amount of **MI-538**. For example, to prepare 1 mL of a 10 mM stock solution, use 5.67 mg of **MI-538**.
- Add the appropriate volume of fresh, anhydrous DMSO to the powder.
- If necessary, gently warm the vial and/or sonicate until the solid is completely dissolved.
- Aliquot the stock solution into single-use, light-protected vials.
- Store the aliquots at -20°C or -80°C as per the recommended guidelines.

In Vitro Cell Proliferation Assay

- Plate MLL-rearranged leukemia cells (e.g., MV4;11) and a negative control cell line (e.g., HL-60) in appropriate cell culture plates and media.
- Prepare serial dilutions of **MI-538** from your stock solution in cell culture media.
- Treat the cells with a range of **MI-538** concentrations. Include a DMSO-only vehicle control.
- Incubate the cells for the desired period (e.g., 72 hours).
- Assess cell viability using a standard method such as MTS or CellTiter-Glo assay.
- Calculate the GI₅₀ value for each cell line.

Visualizations

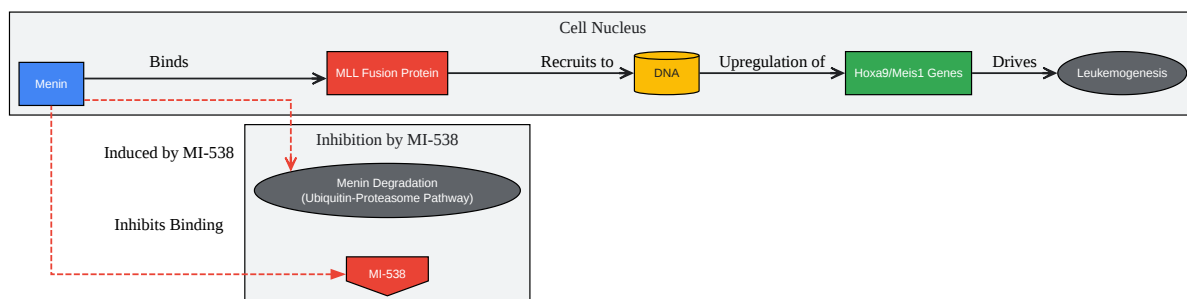

[Click to download full resolution via product page](#)

Caption: Mechanism of action of **MI-538** in inhibiting the menin-MLL interaction.

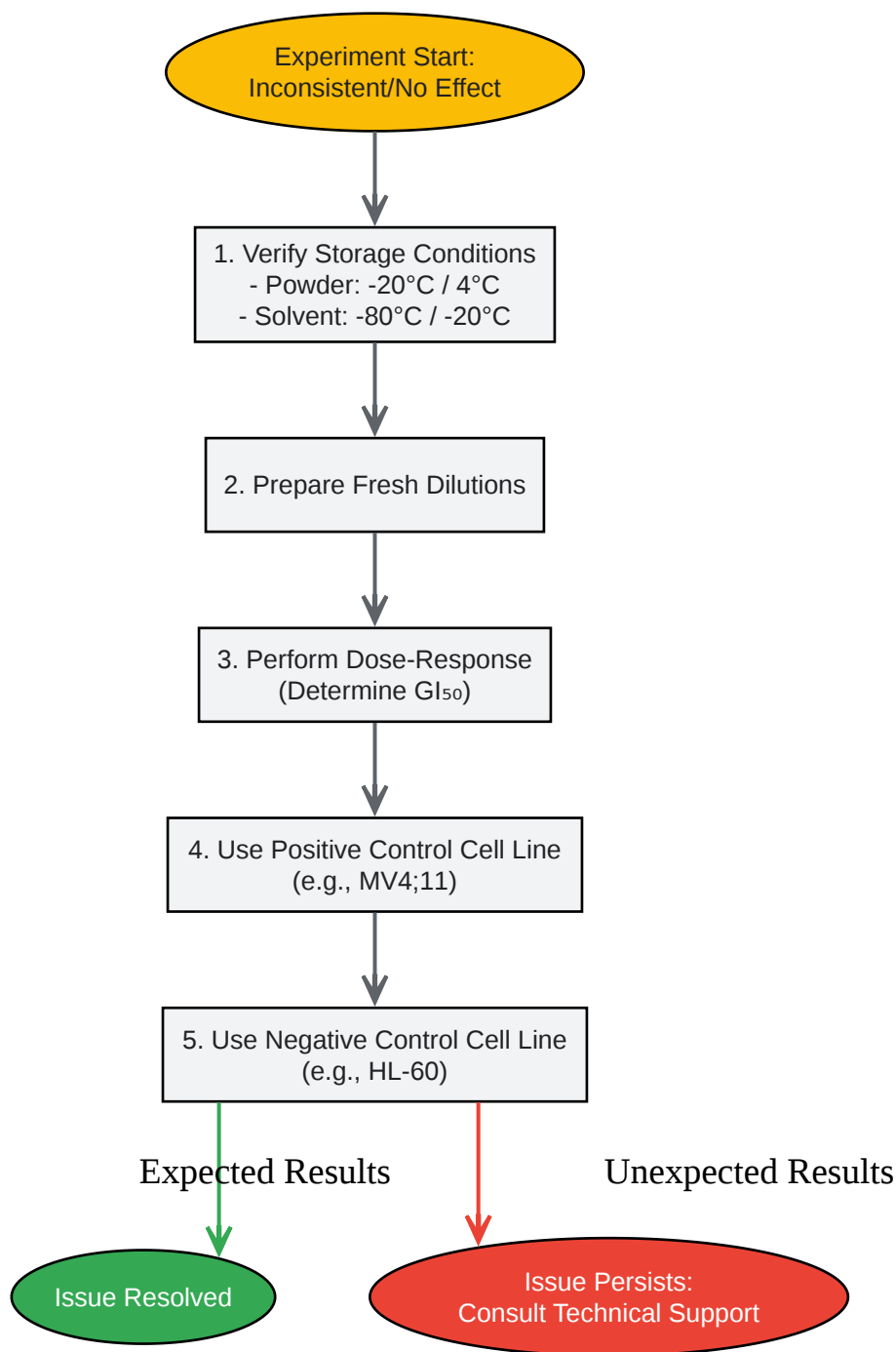

[Click to download full resolution via product page](#)

Caption: Troubleshooting workflow for inconsistent experimental results with **MI-538**.

Need Custom Synthesis?

BenchChem offers custom synthesis for rare earth carbides and specific isotopic labeling.

Email: info@benchchem.com or [Request Quote Online](#).

References

- [1. medchemexpress.com \[medchemexpress.com\]](https://www.medchemexpress.com)
- [2. abmole.com \[abmole.com\]](https://www.abmole.com)
- [3. Disruption of the menin-MLL interaction triggers menin protein degradation via ubiquitin-proteasome pathway - PMC \[pmc.ncbi.nlm.nih.gov\]](https://pubmed.ncbi.nlm.nih.gov/31111111/)
- To cite this document: BenchChem. [MI-538 stability and storage conditions]. BenchChem, [2026]. [Online PDF]. Available at: [\[https://www.benchchem.com/product/b15569956/docs#mi-538-stability-and-storage-conditions\]](https://www.benchchem.com/product/b15569956/docs#mi-538-stability-and-storage-conditions)

Disclaimer & Data Validity:

The information provided in this document is for Research Use Only (RUO) and is strictly not intended for diagnostic or therapeutic procedures. While BenchChem strives to provide accurate protocols, we make no warranties, express or implied, regarding the fitness of this product for every specific experimental setup.

Technical Support: The protocols provided are for reference purposes. Unsure if this reagent suits your experiment?

Need Industrial/Bulk Grade? [Request Custom Synthesis Quote](#)

BenchChem

Our mission is to be the trusted global source of essential and advanced chemicals, empowering scientists and researchers to drive progress in science and industry.

Contact

Address: 3281 E Guasti Rd
Ontario, CA 91761, United States

Phone: (601) 213-4426

Email: info@benchchem.com

Contact our Ph.D. Support Team for a compatibility check