

# An In-depth Technical Guide to Docosahexaenoyl Glycine

**Author:** BenchChem Technical Support Team. **Date:** April 2026

## Compound of Interest

Compound Name: *Docosahexaenoyl glycine*

Cat. No.: *B15569692*

[Get Quote](#)

For Researchers, Scientists, and Drug Development Professionals

## Abstract

**Docosahexaenoyl glycine** (DHA-Gly) is an endogenous N-acyl amino acid, a class of lipid signaling molecules receiving increasing attention for their diverse biological activities. Structurally, it consists of the omega-3 fatty acid docosahexaenoic acid (DHA) linked to the amino acid glycine via an amide bond. This guide provides a comprehensive overview of the current scientific understanding of DHA-Gly, including its synthesis, analytical quantification, and biological functions, with a particular focus on its role in cellular signaling and inflammation. Detailed experimental protocols and quantitative data are presented to facilitate further research and drug development efforts targeting this molecule.

## Chemical Properties and Synthesis

**Docosahexaenoyl glycine** is a lipoamino acid with a molecular formula of  $C_{24}H_{35}NO_3$  and a molecular weight of 385.5 g/mol. Its structure combines the hydrophobicity of the long-chain polyunsaturated fatty acid DHA with the hydrophilicity of the glycine moiety.

## Chemical Synthesis

A standard method for the chemical synthesis of N-acyl amino acids like DHA-Gly involves the acylation of the amino acid with the corresponding fatty acid chloride.

#### Experimental Protocol: Chemical Synthesis of **Docosahexaenoyl Glycine**

- **Activation of Docosahexaenoic Acid:** Docosahexaenoic acid (DHA) is converted to its acyl chloride derivative. Thionyl chloride ( $\text{SOCl}_2$ ) or oxalyl chloride ( $(\text{COCl})_2$ ) can be used as the activating agent. The reaction is typically carried out in an inert solvent like dichloromethane (DCM) or chloroform at room temperature.
- **Acylation of Glycine:** Glycine is dissolved in a suitable aqueous or mixed solvent system, often with a base such as sodium hydroxide or triethylamine to deprotonate the amino group. The DHA-Cl, dissolved in an inert organic solvent, is then added dropwise to the glycine solution under vigorous stirring at a controlled temperature (e.g., 0-4°C) to facilitate the amide bond formation.
- **Work-up and Purification:** After the reaction is complete, the organic and aqueous layers are separated. The organic layer is washed sequentially with dilute acid (e.g., 1M HCl) and brine to remove unreacted glycine and base. The organic solvent is then evaporated under reduced pressure. The crude product is purified using column chromatography on silica gel with a suitable solvent system (e.g., a gradient of methanol in chloroform) to yield pure **Docosahexaenoyl glycine**.

## Enzymatic Synthesis

Enzymatic synthesis offers a greener and more specific alternative to chemical methods. Lipases are commonly employed for the N-acylation of amino acids.

#### Experimental Protocol: Enzymatic Synthesis of **Docosahexaenoyl Glycine**<sup>[1][2][3]</sup>

- **Enzyme Selection:** A commercially available lipase, such as *Candida antarctica* lipase B (CALB), is often used due to its broad substrate specificity and stability.
- **Reaction Setup:** Docosahexaenoic acid (or its methyl ester) and glycine are dissolved in an appropriate organic solvent (e.g., acetonitrile or a mixture of t-butanol and hexane). The immobilized lipase is added to the reaction mixture.

- **Reaction Conditions:** The reaction is typically carried out at a controlled temperature (e.g., 40-50°C) with constant shaking or stirring for a period of 24-48 hours.
- **Monitoring and Purification:** The progress of the reaction can be monitored by thin-layer chromatography (TLC) or high-performance liquid chromatography (HPLC). Upon completion, the enzyme is removed by filtration. The solvent is evaporated, and the product is purified by column chromatography as described in the chemical synthesis protocol.

## Analytical Methodology: Quantification by LC-MS/MS

Liquid chromatography-tandem mass spectrometry (LC-MS/MS) is the gold standard for the sensitive and specific quantification of endogenous lipids like DHA-Gly in biological matrices.

Experimental Protocol: LC-MS/MS Quantification of **Docosahexaenoyl Glycine**<sup>[4][5]</sup>

- **Sample Preparation (Lipid Extraction):**
  - To 100 µL of biological sample (e.g., plasma, brain homogenate), add an internal standard (e.g., d8-N-arachidonoyl glycine).
  - Perform a liquid-liquid extraction using a solvent system such as chloroform:methanol (2:1, v/v).
  - Vortex the mixture thoroughly and centrifuge to separate the phases.
  - Collect the lower organic phase containing the lipids.
  - Evaporate the solvent under a stream of nitrogen.
  - Reconstitute the dried lipid extract in a suitable solvent for LC-MS/MS analysis (e.g., 100 µL of methanol).
- **Liquid Chromatography (LC) Parameters:**
  - **Column:** A reverse-phase C18 column (e.g., 2.1 mm x 100 mm, 1.8 µm particle size) is suitable for separating DHA-Gly from other lipids.

- Mobile Phase A: Water with 0.1% formic acid.
- Mobile Phase B: Acetonitrile with 0.1% formic acid.
- Gradient: A linear gradient from 50% to 95% B over 10 minutes, followed by a hold at 95% B for 2 minutes, and then re-equilibration at 50% B for 3 minutes.
- Flow Rate: 0.3 mL/min.
- Injection Volume: 5-10  $\mu$ L.
- Tandem Mass Spectrometry (MS/MS) Parameters:
  - Ionization Mode: Electrospray Ionization (ESI) in positive mode.
  - Multiple Reaction Monitoring (MRM):
    - Parent Ion (Q1):  $m/z$  386.3 (corresponding to  $[M+H]^+$  of DHA-Gly).
    - Product Ion (Q3): A characteristic fragment ion, such as the one resulting from the loss of the glycine moiety, should be monitored. The exact  $m/z$  would be determined by direct infusion of a DHA-Gly standard.
  - Collision Energy and other parameters: These will need to be optimized for the specific instrument being used to achieve maximum sensitivity.

## Biological Activities and Signaling Pathways

DHA-Gly exhibits a range of biological activities, primarily centered around the modulation of specific cellular receptors and its anti-inflammatory properties.

### Interaction with GPR55

**Docosahexaenoyl glycine** has been identified as an inverse agonist of the G-protein coupled receptor 55 (GPR55).[6] This interaction can trigger downstream signaling cascades.

GPR55 Signaling Pathway

Upon interaction with GPR55, a signaling cascade is initiated, often involving the Gα13 subunit of the heterotrimeric G-protein.[7][8] This leads to the activation of the small GTPase RhoA and its downstream effector, Rho-associated coiled-coil containing protein kinase (ROCK).[8][9] The activation of this pathway can lead to changes in the actin cytoskeleton and the activation of transcription factors such as the Nuclear Factor of Activated T-cells (NFAT) and cAMP response element-binding protein (CREB).[7][8][9]

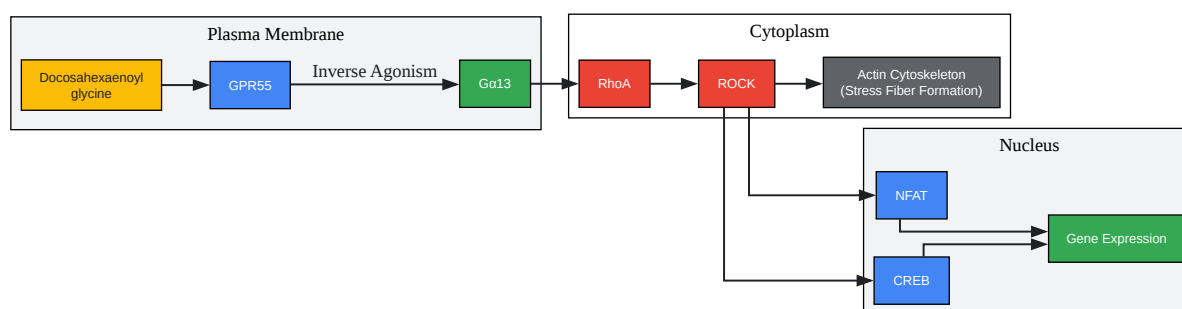

[Click to download full resolution via product page](#)

**Caption:** GPR55 Signaling Pathway of **Docosahexaenoyl Glycine**.

## Modulation of TRPV4 Channels

DHA-Gly has been shown to potentiate the activity of the Transient Receptor Potential Vanilloid 4 (TRPV4) channel, a non-selective cation channel involved in various physiological processes. [6]

### TRPV4 Signaling Pathway

The potentiation of TRPV4 by DHA-Gly leads to an influx of calcium ions ( $\text{Ca}^{2+}$ ) into the cell. This increase in intracellular calcium can activate downstream signaling molecules, including Protein Kinase C (PKC) and Calcium/Calmodulin-dependent Protein Kinase II (CaMKII).[10][11]

These kinases can then phosphorylate various target proteins, leading to a range of cellular responses.

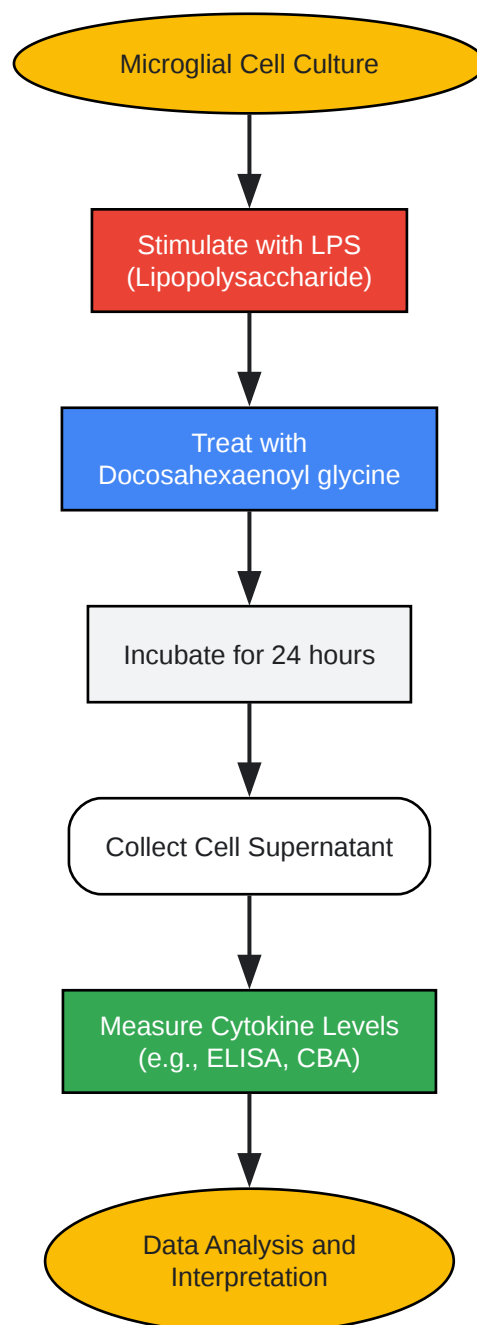
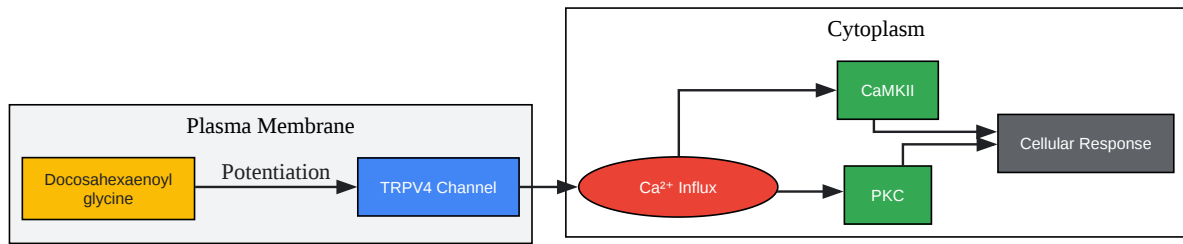

[Click to download full resolution via product page](#)

### Need Custom Synthesis?

BenchChem offers custom synthesis for rare earth carbides and specific isotopic labeling.

Email: [info@benchchem.com](mailto:info@benchchem.com) or [Request Quote Online](#).

## References

- [1. Chemo-enzymatic synthesis of N-arachidonoyl glycine - PubMed \[pubmed.ncbi.nlm.nih.gov\]](#)
- [2. Enzymatic Strategies for the Biosynthesis of N-Acyl Amino Acid Amides - PubMed \[pubmed.ncbi.nlm.nih.gov\]](#)
- [3. researchgate.net \[researchgate.net\]](#)
- [4. researchgate.net \[researchgate.net\]](#)
- [5. Measuring the Content of Endocannabinoid-Like Compounds in Biological Fluids: A Critical Overview of Sample Preparation Methodologies - PMC \[pmc.ncbi.nlm.nih.gov\]](#)
- [6. biorxiv.org \[biorxiv.org\]](#)
- [7. Activation of GPR55 increases neural stem cell proliferation and promotes early adult hippocampal neurogenesis - PMC \[pmc.ncbi.nlm.nih.gov\]](#)
- [8. The GPR55 ligand L-alpha-lysophosphatidylinositol promotes RhoA-dependent Ca<sup>2+</sup> signaling and NFAT activation - PubMed \[pubmed.ncbi.nlm.nih.gov\]](#)
- [9. GPR55 ligands promote receptor coupling to multiple signalling pathways - PMC \[pmc.ncbi.nlm.nih.gov\]](#)
- [10. Molecular Mechanisms of TRPV4 Gating - TRP Ion Channel Function in Sensory Transduction and Cellular Signaling Cascades - NCBI Bookshelf \[ncbi.nlm.nih.gov\]](#)
- [11. TRPV4: A Multifunctional Nonselective Cation Channel with Complex Regulation - TRP Ion Channel Function in Sensory Transduction and Cellular Signaling Cascades - NCBI Bookshelf \[ncbi.nlm.nih.gov\]](#)
- To cite this document: BenchChem. [An In-depth Technical Guide to Docosahexaenoyl Glycine]. BenchChem, [2026]. [Online PDF]. Available at: [\[https://www.benchchem.com/product/b15569692/docs#an-in-depth-technical-guide-to-docosahexaenoyl-glycine\]](https://www.benchchem.com/product/b15569692/docs#an-in-depth-technical-guide-to-docosahexaenoyl-glycine)

**Disclaimer & Data Validity:**

The information provided in this document is for Research Use Only (RUO) and is strictly not intended for diagnostic or therapeutic procedures. While BenchChem strives to provide accurate protocols, we make no warranties, express or implied, regarding the fitness of this product for every specific experimental setup.

**Technical Support:** The protocols provided are for reference purposes. Unsure if this reagent suits your experiment?

**Need Industrial/Bulk Grade?** [Request Custom Synthesis Quote](#)

## BenchChem

Our mission is to be the trusted global source of essential and advanced chemicals, empowering scientists and researchers to drive progress in science and industry.

### Contact

Address: 3281 E Guasti Rd  
Ontario, CA 91761, United States  
Phone: (601) 213-4426  
Email: [info@benchchem.com](mailto:info@benchchem.com)

[Contact our Ph.D. Support Team for a compatibility check](#)