

Addressing off-target effects of Balomenib in research models

Author: BenchChem Technical Support Team. **Date:** April 2026

Compound of Interest

Compound Name: *Balomenib*
CAS No.: 2939850-17-4
Cat. No.: B15569023

[Get Quote](#)

Technical Support Center: Balomenib Research

This technical support center provides troubleshooting guides and frequently asked questions (FAQs) for researchers using **Balomenib** in various experimental models. Our goal is to help you identify and address potential off-target effects and other common issues to ensure the accuracy and reproducibility of your results.

Frequently Asked Questions (FAQs)

Q1: What is the primary mechanism of action for **Balomenib**?

A1: **Balomenib** is a potent and selective small molecule inhibitor of the menin-KMT2A (MLL) protein-protein interaction.^{[1][2][3]} Its mechanism does not involve direct kinase inhibition. By disrupting the menin-KMT2A complex, **Balomenib** inhibits the transcription of key downstream target genes, such as HOX and MEIS1, which are critical for the survival of leukemia cells with KMT2A rearrangements or NPM1 mutations.^{[4][5]}

Q2: Is **Balomenib** a kinase inhibitor? What are its known off-target effects?

A2: **Balomenib** is not a kinase inhibitor. It is designed to be highly selective for the menin protein. Pre-clinical data suggest that **Balomenib** has an improved safety profile compared to other molecules in its class, with no evidence of QTc prolongation or significant induction of cytochrome P450 3A4 metabolism. The most prominent clinically observed side effect is differentiation syndrome, which is considered an on-target effect related to the differentiation of leukemic blasts. While broad off-target kinase activity is not a primary concern, as with any small molecule inhibitor, off-target effects can occur in research models, especially at concentrations significantly higher than the IC50.

Q3: What are the typical research models used to study **Balomenib**?

A3: **Balomenib** is most commonly studied in in vitro and in vivo models of acute myeloid leukemia (AML) that harbor KMT2A rearrangements or NPM1 mutations. Common cell lines include MV4-11 and MOLM-13. Xenograft models using these cell lines in immunocompromised mice are also frequently employed to assess in vivo efficacy.

Q4: What is Differentiation Syndrome and how can I identify it in my models?

A4: Differentiation Syndrome (DS) is a common on-target effect of therapies that induce differentiation of cancer cells. In clinical settings, it is characterized by symptoms such as fever, weight gain, respiratory distress, and edema. In animal models, you might observe weight gain, respiratory distress, or organ infiltration by maturing myeloid cells. In vitro, you may see morphological changes in your cell cultures consistent with myeloid differentiation (e.g., increased cell size, granularity, and expression of differentiation markers like CD11b and CD14).

Troubleshooting Guide: Addressing Unexpected Results

This guide is designed to help you troubleshoot common issues and unexpected results when using **Balomenib** in your experiments.

Observed Problem	Potential Cause	Recommended Action
Reduced potency or lack of expected phenotype (e.g., no growth inhibition in sensitive cell lines)	<ol style="list-style-type: none"> 1. Compound Instability: Balomenib degradation due to improper storage or handling. 2. Cell Line Integrity: Misidentification, contamination, or genetic drift of the cell line. 3. Incorrect Dosing: Calculation error or use of a concentration below the effective range. 	<ol style="list-style-type: none"> 1. Verify Compound: Confirm proper storage conditions (as per supplier's instructions) and prepare fresh stock solutions. 2. Authenticate Cell Line: Perform STR profiling to confirm cell line identity. Test for mycoplasma contamination. 3. Dose-Response Curve: Perform a dose-response experiment to determine the IC50 in your specific cell line and compare it to published values.
High levels of cell death in resistant cell lines or at low concentrations in sensitive lines	<ol style="list-style-type: none"> 1. Off-Target Cytotoxicity: At high concentrations, Balomenib may have off-target effects leading to general cytotoxicity. 2. Solvent Toxicity: The vehicle (e.g., DMSO) concentration may be too high. 	<ol style="list-style-type: none"> 1. Titrate Concentration: Use the lowest effective concentration that inhibits the on-target pathway. 2. Control for Solvent Effects: Ensure the final solvent concentration is consistent across all treatment groups and is below cytotoxic levels (typically <0.1% for DMSO). 3. Alternative Inhibitor: Use a structurally different menin-KMT2A inhibitor to see if the effect is reproducible.
Unexpected changes in signaling pathways unrelated to the menin-KMT2A axis	<ol style="list-style-type: none"> 1. Indirect Pathway Modulation: Inhibition of the primary target may lead to feedback loops or crosstalk with other pathways. 2. Potential Non-Menin Off-Target Effects: Although selective, Balomenib could interact with 	<ol style="list-style-type: none"> 1. Pathway Analysis: Use techniques like Western blotting or RNA sequencing to investigate the activation state of key signaling pathways. 2. Target Knockdown: Use siRNA or CRISPR/Cas9 to knockdown menin and

other proteins at high concentrations.

compare the phenotype to that observed with Balomenib treatment. A similar phenotype suggests an on-target effect. 3. Kinase Profiling: If off-target kinase effects are suspected, consider a broad-spectrum kinase profiling assay, although this is less likely to be the cause given Balomenib's mechanism.

Inconsistent results between experiments

1. Experimental Variability: Differences in cell passage number, seeding density, or reagent quality. 2. Compound Batch Variation: Differences in the purity or activity of Balomenib between batches.

1. Standardize Protocols: Maintain consistent experimental parameters, including cell culture conditions and reagent sources. 2. Batch Validation: If you suspect batch-to-batch variability, test new batches against a previous batch with known activity.

Quantitative Data Summary

The following table summarizes the reported potency of **Balomenib** in commonly used AML cell lines.

Cell Line	Genotype	IC50 / CC50	Reference
MV4-11	KMT2A-rearranged	< 0.1 μ M	
MOLM-13	KMT2A-rearranged	0.1 - 0.5 μ M	
HEK293	N/A (Control)	< 2 μ M	

Key Experimental Protocols

Protocol 1: Cell Viability Assay (MTS/MTT)

- **Cell Seeding:** Plate cells in a 96-well plate at a predetermined optimal density. For suspension cells like MV4-11 and MOLM-13, a density of 1×10^4 to 5×10^4 cells per well is common.
- **Compound Treatment:** Prepare a serial dilution of **Balomenib** in culture medium. Add the diluted compound to the appropriate wells. Include a vehicle control (e.g., DMSO) and a positive control for cell death (e.g., staurosporine).
- **Incubation:** Incubate the plate for 48-72 hours at 37°C in a humidified incubator with 5% CO₂.
- **Reagent Addition:** Add MTS or MTT reagent to each well according to the manufacturer's instructions.
- **Incubation with Reagent:** Incubate for 1-4 hours until a color change is apparent.
- **Data Acquisition:** Measure the absorbance at the appropriate wavelength (e.g., 490 nm for MTS).
- **Data Analysis:** Normalize the absorbance values to the vehicle control and plot the results as a dose-response curve to calculate the IC₅₀.

Protocol 2: Western Blot for Target Engagement

- **Cell Treatment:** Treat cells with **Balomenib** at various concentrations and time points. Include a vehicle control.
- **Cell Lysis:** Harvest the cells, wash with cold PBS, and lyse in RIPA buffer supplemented with protease and phosphatase inhibitors.
- **Protein Quantification:** Determine the protein concentration of each lysate using a BCA or Bradford assay.
- **SDS-PAGE and Transfer:** Load equal amounts of protein onto an SDS-PAGE gel, separate by electrophoresis, and transfer to a PVDF or nitrocellulose membrane.

- Antibody Incubation: Block the membrane and incubate with a primary antibody against a downstream target of the menin-KMT2A complex (e.g., Meis1, or a specific H3K79me2 mark if expecting changes in histone methylation) or a housekeeping protein (e.g., GAPDH, β -actin). Follow with a horseradish peroxidase (HRP)-conjugated secondary antibody.
- Detection: Visualize the protein bands using an enhanced chemiluminescence (ECL) substrate and an imaging system.
- Analysis: Quantify the band intensities and normalize to the loading control to determine the effect of **Balomenib** on protein expression.

Visualizations

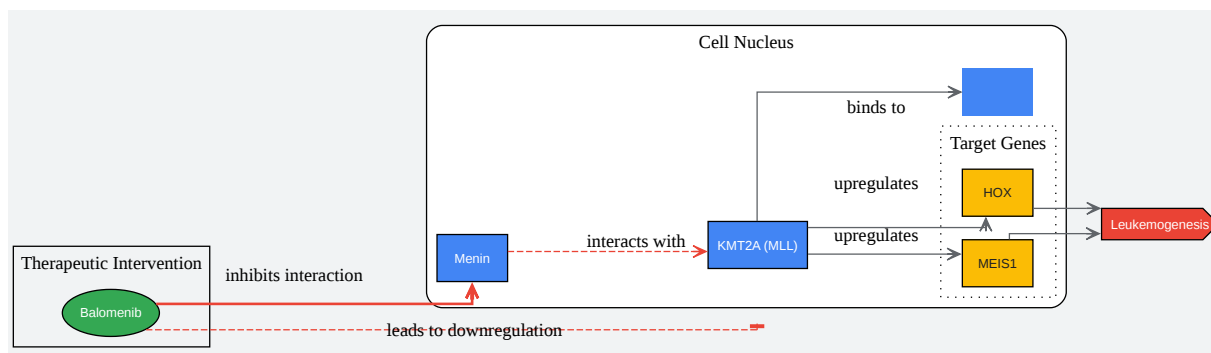

[Click to download full resolution via product page](#)

Caption: Mechanism of action of **Balomenib** in inhibiting the menin-KMT2A interaction.

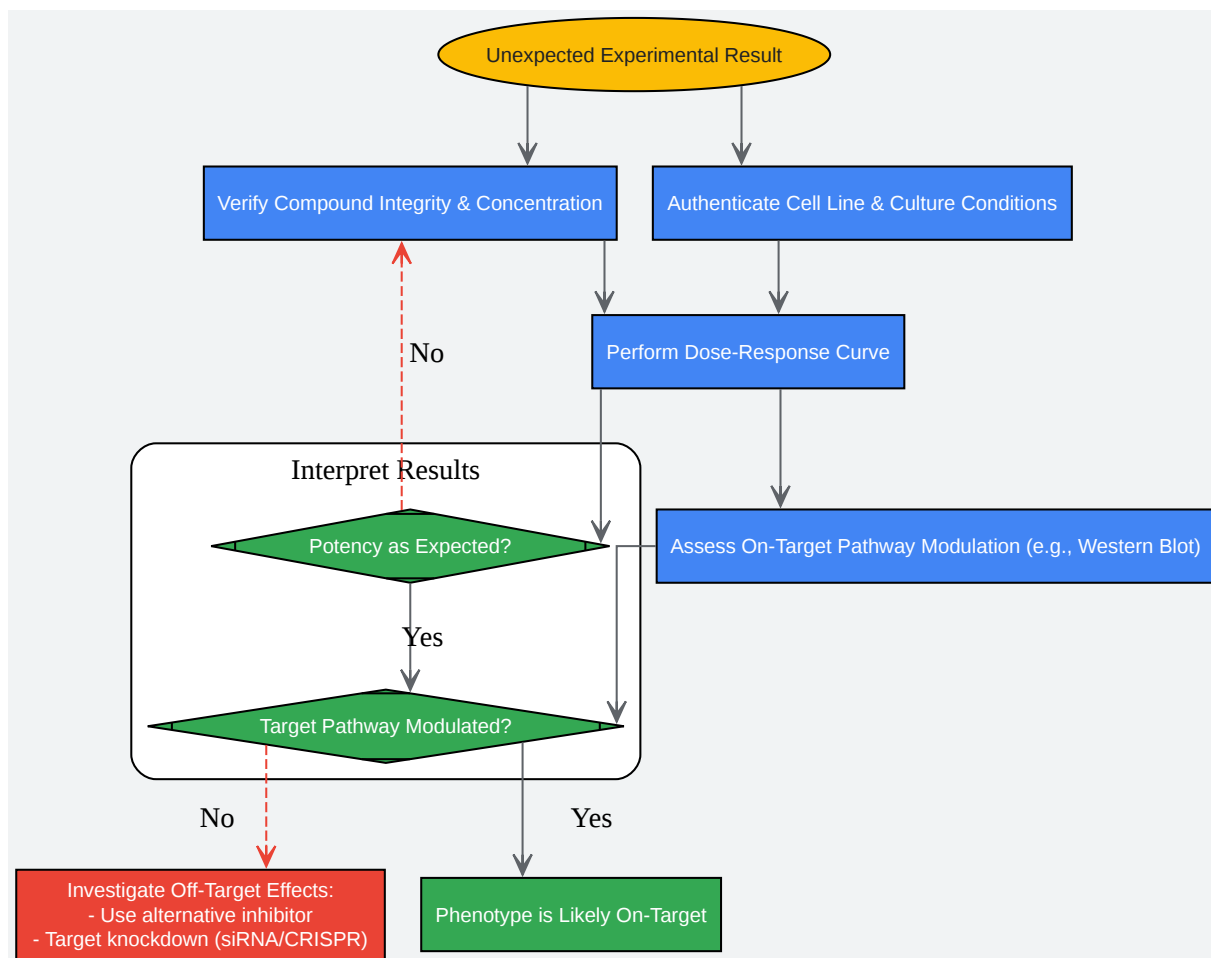

[Click to download full resolution via product page](#)

Need Custom Synthesis?

BenchChem offers custom synthesis for rare earth carbides and specific isotopic labeling.

Email: info@benchchem.com or [Request Quote Online](#).

References

- [1. medchemexpress.com \[medchemexpress.com\]](https://www.medchemexpress.com)
- [2. Balamenib - Drug Targets, Indications, Patents - Synapse \[synapse.patsnap.com\]](https://synapse.patsnap.com)
- [3. EILEAN THERAPEUTICS APPROVED TO INITIATE FIRST PATIENT TRIAL WITH BALAMENIB \(ZE63-0302\), A SELECTIVE BEST-IN-CLASS MENIN INHIBITOR \[prnewswire.com\]](https://prnewswire.com)
- [4. A 2024 Update on Menin Inhibitors. A New Class of Target Agents against KMT2A-Rearranged and NPM1-Mutated Acute Myeloid Leukemia - PMC \[pmc.ncbi.nlm.nih.gov\]](https://pubmed.ncbi.nlm.nih.gov)
- [5. Menin inhibition for the treatment of acute leukemia - PubMed \[pubmed.ncbi.nlm.nih.gov\]](https://pubmed.ncbi.nlm.nih.gov)
- To cite this document: BenchChem. [Addressing off-target effects of Balomenib in research models]. BenchChem, [2026]. [Online PDF]. Available at: [\[https://www.benchchem.com/product/b15569023/docs#addressing-off-target-effects-of-balomenib-in-research-models\]](https://www.benchchem.com/product/b15569023/docs#addressing-off-target-effects-of-balomenib-in-research-models)

Disclaimer & Data Validity:

The information provided in this document is for Research Use Only (RUO) and is strictly not intended for diagnostic or therapeutic procedures. While BenchChem strives to provide accurate protocols, we make no warranties, express or implied, regarding the fitness of this product for every specific experimental setup.

Technical Support: The protocols provided are for reference purposes. Unsure if this reagent suits your experiment?

Need Industrial/Bulk Grade? [Request Custom Synthesis Quote](#)

BenchChem

Our mission is to be the trusted global source of essential and advanced chemicals, empowering scientists and researchers to drive progress in science and industry.

Contact

Address: 3281 E Guasti Rd
Ontario, CA 91761, United States
Phone: (601) 213-4426
Email: info@benchchem.com

Contact our Ph.D. Support Team for a compatibility check