

Technical Support Center: Optimizing Izumenolide Production

Author: BenchChem Technical Support Team. **Date:** April 2026

Compound of Interest

Compound Name: *Izumenolide*

Cat. No.: *B15567312*

[Get Quote](#)

This technical support center provides researchers, scientists, and drug development professionals with a comprehensive guide to improving the yield of **Izumenolide**, a bioactive compound produced by the bacterium *Streptomyces wuyuanensis*. The information is presented in a question-and-answer format to directly address common issues encountered during experimentation.

Troubleshooting Guide

This guide addresses specific problems that can lead to low **Izumenolide** yield and offers systematic solutions.

Question 1: Why is my **Izumenolide** yield consistently low or nonexistent?

Answer: Low or no production of **Izumenolide** can stem from several factors, ranging from the quality of the inoculum to the composition of the fermentation medium and the physical parameters of the fermentation process.

Possible Causes & Solutions:

- **Suboptimal Inoculum:** The age and quality of the seed culture are critical. An old or poorly grown seed culture will lead to a long lag phase and poor production.
 - **Protocol:** Standardize your seed culture preparation. Use a fresh, actively growing culture for inoculation. Ensure a consistent spore concentration or mycelial density.
- **Inappropriate Media Composition:** The balance of carbon, nitrogen, and essential minerals in the fermentation medium is crucial for secondary metabolite production in *Streptomyces*.
 - **Protocol:** Optimize the fermentation medium using a systematic approach like Design of Experiments (DoE). Start with a basal medium and vary the concentrations of key components. A good starting point for *Streptomyces* fermentation is provided in the table below.
- **Incorrect Fermentation Parameters:** pH, temperature, dissolved oxygen, and agitation are critical physical parameters that influence both microbial growth and secondary metabolite synthesis.
 - **Protocol:** Monitor and control these parameters throughout the fermentation process. The optimal conditions should be determined empirically for your specific bioreactor setup. General ranges for *Streptomyces* are provided in the tables below.

Question 2: My *Streptomyces wuyuanensis* culture shows good biomass growth, but **Izumenolide** production is minimal. What could be the issue?

Answer: This common issue, known as the decoupling of growth and production, often arises when the metabolic pathways favor primary metabolism (growth) over secondary metabolism (**Izumenolide** production).

Possible Causes & Solutions:

- **Nutrient Repression:** High concentrations of readily metabolizable carbon or nitrogen sources can repress the genes responsible for secondary metabolite biosynthesis. Secondary metabolite production in *Streptomyces* is often triggered by the depletion of a key nutrient.

- Strategy: Implement a fed-batch fermentation strategy to maintain key nutrients at a low, growth-limiting concentration during the production phase.
- Unfavorable pH Shift: The optimal pH for *Streptomyces* growth may differ from the optimal pH for **Izumenolide** production.
 - Strategy: Implement a two-stage pH control strategy. Maintain the pH at the optimal level for growth during the initial phase and then shift it to a pH that favors secondary metabolite production.
- Lack of Precursor Supply: **Izumenolide**, as a polyketide, is synthesized from simple carboxylic acid precursors derived from primary metabolism. Insufficient precursor pools can limit production.
 - Strategy: Supplement the fermentation medium with known precursors of polyketide biosynthesis, such as acetate, propionate, or specific amino acids, during the production phase.

Question 3: I am having difficulty extracting and purifying **Izumenolide** from the fermentation broth. What methods are recommended?

Answer: The choice of extraction and purification methods depends on the physicochemical properties of **Izumenolide**. As a macrolide, it is likely to be a relatively nonpolar molecule.

Recommended Protocol:

- Cell Separation: Separate the mycelium from the fermentation broth by centrifugation or filtration. **Izumenolide** may be present in both the mycelium and the supernatant, so both should be processed.
- Extraction:
 - Supernatant: Use a non-polar solvent such as ethyl acetate or butanol for liquid-liquid extraction.
 - Mycelium: First, disrupt the cells using methods like sonication or bead beating in the presence of a solvent like acetone or methanol. Follow this with extraction using ethyl

acetate.

- Purification: A multi-step chromatography approach is generally required.
 - Silica Gel Chromatography: Use a gradient of solvents with increasing polarity (e.g., hexane-ethyl acetate followed by ethyl acetate-methanol) to achieve initial separation.
 - Preparative High-Performance Liquid Chromatography (HPLC): Employ a reverse-phase column (e.g., C18) with a suitable mobile phase (e.g., acetonitrile-water or methanol-water gradient) for final purification.
- Analysis: Confirm the purity and identity of **Izumenolide** using analytical techniques such as HPLC, Mass Spectrometry (MS), and Nuclear Magnetic Resonance (NMR) spectroscopy.

Frequently Asked Questions (FAQs)

Q1: What is the producing organism of **Izumenolide**? A1: **Izumenolide** is produced by *Streptomyces wuyuanensis*, a Gram-positive bacterium originally isolated from a saline sample in China.^{[1][2]}

Q2: To what class of compounds does **Izumenolide** belong? A2: **Izumenolide** is a macrolide, which is a class of polyketide secondary metabolites. Polyketides are synthesized by a family of enzymes called polyketide synthases (PKSs).

Q3: What are the key considerations for optimizing the fermentation medium for **Izumenolide** production? A3: The key is to find the right balance of nutrients to support initial growth and then trigger a switch to secondary metabolism. Important factors include the carbon-to-nitrogen ratio, the specific types of carbon and nitrogen sources, and the presence of essential minerals and trace elements. Statistical methods like Response Surface Methodology (RSM) are powerful tools for this optimization.

Q4: How can I improve **Izumenolide** yield through genetic engineering? A4: While specific genetic targets for **Izumenolide** are not yet published, general strategies for improving polyketide production in *Streptomyces* include:

- Overexpressing positive regulatory genes within the biosynthetic gene cluster.

- Deleting negative regulatory genes.
- Engineering precursor pathways to increase the supply of building blocks for polyketide synthesis.
- Using strong, constitutive promoters to drive the expression of the biosynthetic gene cluster.

Data Presentation

Table 1: Recommended Starting Fermentation Media Composition for *Streptomyces wuyuanensis*

Component	Concentration (g/L)	Role
Soluble Starch	20	Carbon Source
Glucose	10	Carbon Source
Yeast Extract	5	Nitrogen & Growth Factor Source
Peptone	5	Nitrogen Source
K ₂ HPO ₄	1	Phosphate Source & pH Buffer
MgSO ₄ ·7H ₂ O	0.5	Mineral Source
CaCO ₃	2	pH Buffer

Table 2: General Fermentation Parameters for *Streptomyces* Species

Parameter	Optimal Range
Temperature	28-30°C
pH	6.5-7.5
Agitation	200-250 rpm
Aeration	1-1.5 vvm (volume of air per volume of medium per minute)
Fermentation Time	7-10 days

Experimental Protocols & Visualizations

Generalized Polyketide Biosynthetic Pathway

The biosynthesis of macrolides like **Izumanolide** proceeds through a Type I Polyketide Synthase (PKS) pathway. This is a multi-enzyme complex organized into modules. Each module is responsible for the addition and modification of a two-carbon unit to the growing polyketide chain. The following diagram illustrates a generalized modular PKS system.

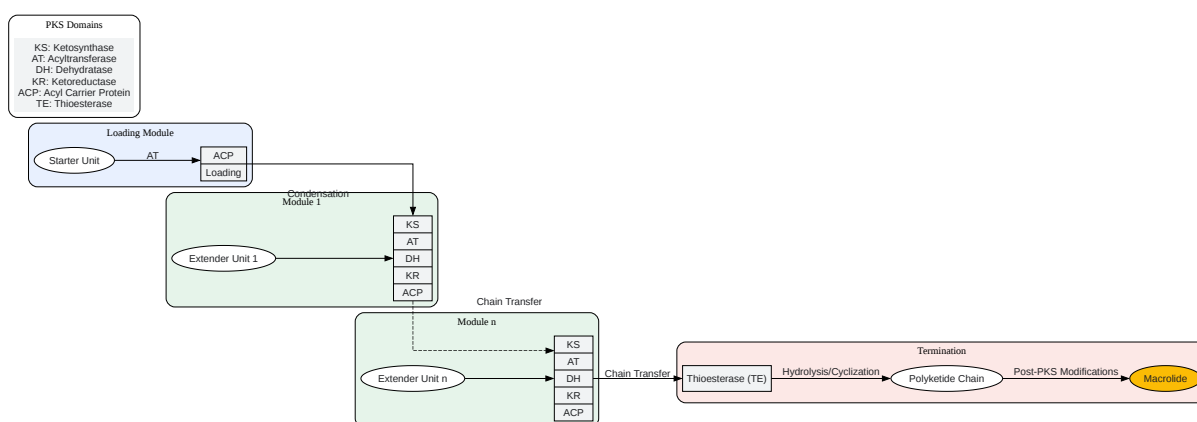

[Click to download full resolution via product page](#)

Caption: Generalized modular Polyketide Synthase (PKS) pathway for macrolide biosynthesis.

Experimental Workflow for Izumenolide Production and Purification

The following workflow outlines the key steps from culture inoculation to the final purified product.

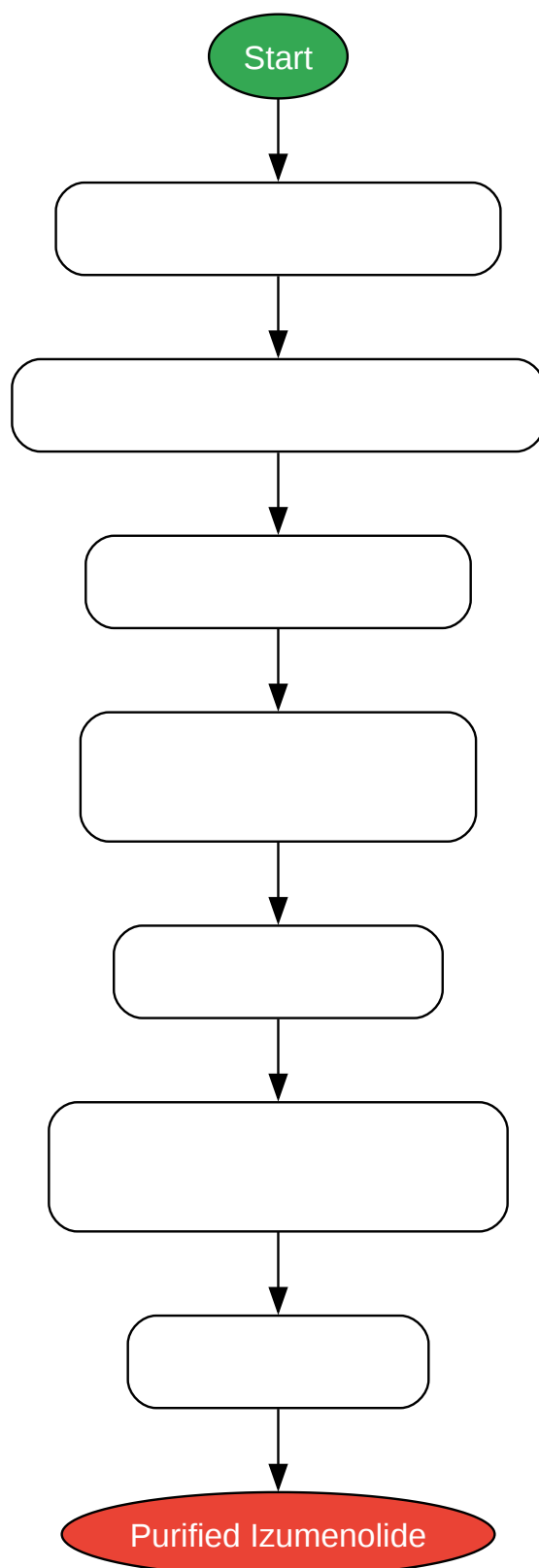

[Click to download full resolution via product page](#)

Caption: Experimental workflow for **Izumenolide** production and purification.

Need Custom Synthesis?

BenchChem offers custom synthesis for rare earth carbides and specific isotopic labeling.

Email: info@benchchem.com or [Request Quote Online](#).

References

- 1. The Application of Regulatory Cascades in Streptomyces: Yield Enhancement and Metabolite Mining - PubMed [pubmed.ncbi.nlm.nih.gov]
- 2. Biosynthetic Potential of Streptomyces Rationalizes Genome-Based Bioprospecting - PMC [pmc.ncbi.nlm.nih.gov]
- To cite this document: BenchChem. [Technical Support Center: Optimizing Izumenolide Production]. BenchChem, [2026]. [Online PDF]. Available at: [https://www.benchchem.com/product/b15567312/docs#technical-support-center-optimizing-izumenolide-production]

Disclaimer & Data Validity:

The information provided in this document is for Research Use Only (RUO) and is strictly not intended for diagnostic or therapeutic procedures. While BenchChem strives to provide accurate protocols, we make no warranties, express or implied, regarding the fitness of this product for every specific experimental setup.

Technical Support: The protocols provided are for reference purposes. Unsure if this reagent suits your experiment?

Need Industrial/Bulk Grade? [Request Custom Synthesis Quote](#)

BenchChem

Our mission is to be the trusted global source of essential and advanced chemicals, empowering scientists and researchers to drive progress in science and industry.

Contact

Address: 3281 E Guasti Rd

Ontario, CA 91761, United States

Phone: (601) 213-4426

Email: info@benchchem.com

[Contact our Ph.D. Support Team for a compatibility check](#)