

# LL-37 vs. Scrambled Peptide: A Comparative Guide for Functional Assays

**Author:** BenchChem Technical Support Team. **Date:** April 2026

## Compound of Interest

Compound Name: LL-37, Human

Cat. No.: B15567582

[Get Quote](#)

For researchers, scientists, and drug development professionals, establishing the specificity of a peptide's biological activity is paramount. This guide provides an objective comparison of the human cathelicidin antimicrobial peptide LL-37 and its scrambled peptide counterpart when used as a negative control in functional assays. The data presented herein underscores the importance of a well-designed control to validate the sequence-specific effects of LL-37.

LL-37 is a 37-amino acid, cationic peptide with a broad spectrum of antimicrobial and immunomodulatory activities. Its functions, which include direct bacterial killing, modulation of inflammatory responses, and promotion of wound healing, are attributed to its specific amino acid sequence and amphipathic  $\alpha$ -helical structure.

To demonstrate that these biological effects are sequence-dependent and not merely due to the peptide's overall charge or amino acid composition, a scrambled peptide is often employed as a negative control. A scrambled peptide is synthesized with the exact same amino acids as LL-37, but in a randomized order, disrupting its specific secondary structure and functional domains.

## Data Presentation: Quantitative Comparison of LL-37 and Scrambled Peptide

The following tables summarize the quantitative data from various functional assays, highlighting the differential performance of LL-37 and its scrambled negative control.

### Table 1: Antimicrobial Activity

Organism	LL-37 MIC ( $\mu\text{g/mL}$ )	Scrambled LL-37 MIC ( $\mu\text{g/mL}$ )	Reference
Escherichia coli	9.38 - 18.75	> 300	[1]
Pseudomonas aeruginosa	15.6 - 75	> 300	[1]
Staphylococcus aureus	9.38 - 18.75	> 300	[1]
Staphylococcus epidermidis	9.38	> 300	[1]
Candida albicans	> 250	Not Active	[2]

MIC: Minimum Inhibitory Concentration

### Table 2: Anti-Inflammatory Activity

Assay	Cell Type	Stimulant	LL-37 Effect	Scrambled LL-37 Effect	Reference
IL-6 Release	Human Bronchial Epithelial Cells (BEAS-2B)	LPS	Inhibition	Little to no effect	[3]
TNF- $\alpha$ Release	Human Neutrophils	LPS	Dose-dependent decrease	Not reported	[4]
IL-8 Release	Human Gingival Fibroblasts	None	Increased release	Not reported	[5]

**Table 3: Cell Migration and Wound Healing**

Assay	Cell Type	LL-37 Effect (% of Control)	Scrambled LL-37 Effect (% of Control)	Reference
Cell Migration	Skin Squamous Carcinoma Cells (A431)	Increased migration (Concentration-dependent)	Not reported	[6]
Wound Healing (in vivo)	Venous Leg Ulcers	50-68% decrease in ulcer area	Placebo control	[7]
Cell Migration	Human Pulp Cells	Induced migration	Not reported	[8]

## Experimental Protocols

Detailed methodologies for key functional assays are provided below.

## Minimum Inhibitory Concentration (MIC) Assay

This assay determines the lowest concentration of a peptide that inhibits the visible growth of a microorganism.

Protocol:

- Preparation of Bacterial Inoculum:
  - Culture bacteria in an appropriate broth medium (e.g., Trypticase Soy Broth) to the mid-logarithmic growth phase.
  - Wash the bacterial cells with a suitable buffer (e.g., 10 mM sodium phosphate buffer, pH 7.4).
  - Dilute the bacterial suspension to a final concentration of approximately  $5 \times 10^5$  colony-forming units (CFU)/mL in the assay medium (e.g., 1% Trypticase Soy Broth in 10 mM Sodium Phosphate buffer).
- Peptide Preparation:
  - Prepare a stock solution of LL-37 and the scrambled peptide in sterile water or a suitable buffer.
  - Perform serial twofold dilutions of the peptides in the assay medium in a 96-well microtiter plate.
- Incubation:
  - Add 10  $\mu$ L of the bacterial inoculum to each well containing the diluted peptides.
  - Include a positive control (bacteria without peptide) and a negative control (medium only).
  - Incubate the plate at 37°C for 18-24 hours.
- Determination of MIC:

- The MIC is defined as the lowest peptide concentration at which no visible bacterial growth is observed.

## Anti-Inflammatory Assay: LPS-Induced Cytokine Release

This assay measures the ability of a peptide to modulate the inflammatory response of immune cells stimulated with lipopolysaccharide (LPS).

Protocol:

- Cell Culture:
  - Culture immune cells (e.g., human neutrophils, macrophages, or a relevant cell line) in an appropriate culture medium.
  - Seed the cells in a 96-well plate at a desired density (e.g.,  $1 \times 10^6$  cells/mL).
- Peptide and Stimulant Treatment:
  - Pre-incubate the cells with various concentrations of LL-37 or the scrambled peptide for a specified time (e.g., 30 minutes).
  - Stimulate the cells with LPS (e.g., 100 ng/mL).
  - Include controls for untreated cells, cells treated with peptide alone, and cells treated with LPS alone.
- Incubation:
  - Incubate the plate at 37°C in a humidified incubator with 5% CO<sub>2</sub> for a designated period (e.g., 4-24 hours).
- Cytokine Measurement:
  - Collect the cell culture supernatants.

- Measure the concentration of pro-inflammatory cytokines (e.g., TNF- $\alpha$ , IL-6, IL-8) in the supernatants using an Enzyme-Linked Immunosorbent Assay (ELISA) kit according to the manufacturer's instructions.

## Cell Migration Assay (Wound Healing/Scratch Assay)

This assay assesses the effect of a peptide on the migration of cells, often used to model wound healing.

Protocol:

- Cell Culture:
  - Grow a confluent monolayer of a suitable cell type (e.g., keratinocytes, fibroblasts) in a culture plate.
- Creating the "Wound":
  - Create a uniform "scratch" or cell-free area in the monolayer using a sterile pipette tip.
  - Wash the cells with phosphate-buffered saline (PBS) to remove detached cells.
- Peptide Treatment:
  - Add fresh culture medium containing different concentrations of LL-37 or the scrambled peptide to the wells.
  - Include a control well with medium only.
- Image Acquisition:
  - Capture images of the scratch at time zero and at regular intervals (e.g., every 6-12 hours) using a microscope with a camera.
- Analysis:
  - Measure the area of the cell-free region in the images at each time point.
  - Calculate the percentage of wound closure over time for each treatment condition.

## Mandatory Visualization

### Signaling Pathway of LL-37 in Immune Modulation

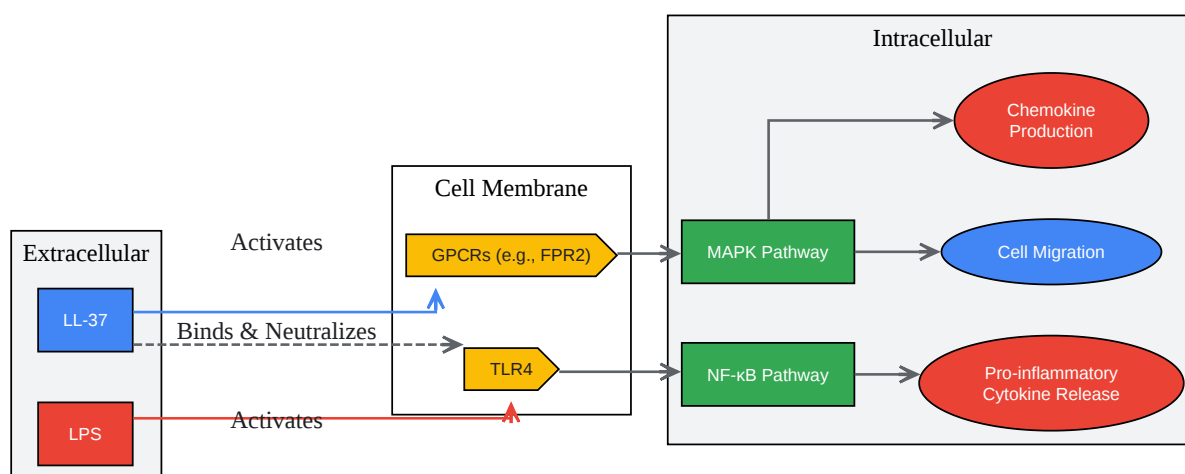

[Click to download full resolution via product page](#)

Caption: LL-37 signaling pathways in immunomodulation.

## Experimental Workflow for MIC Assay

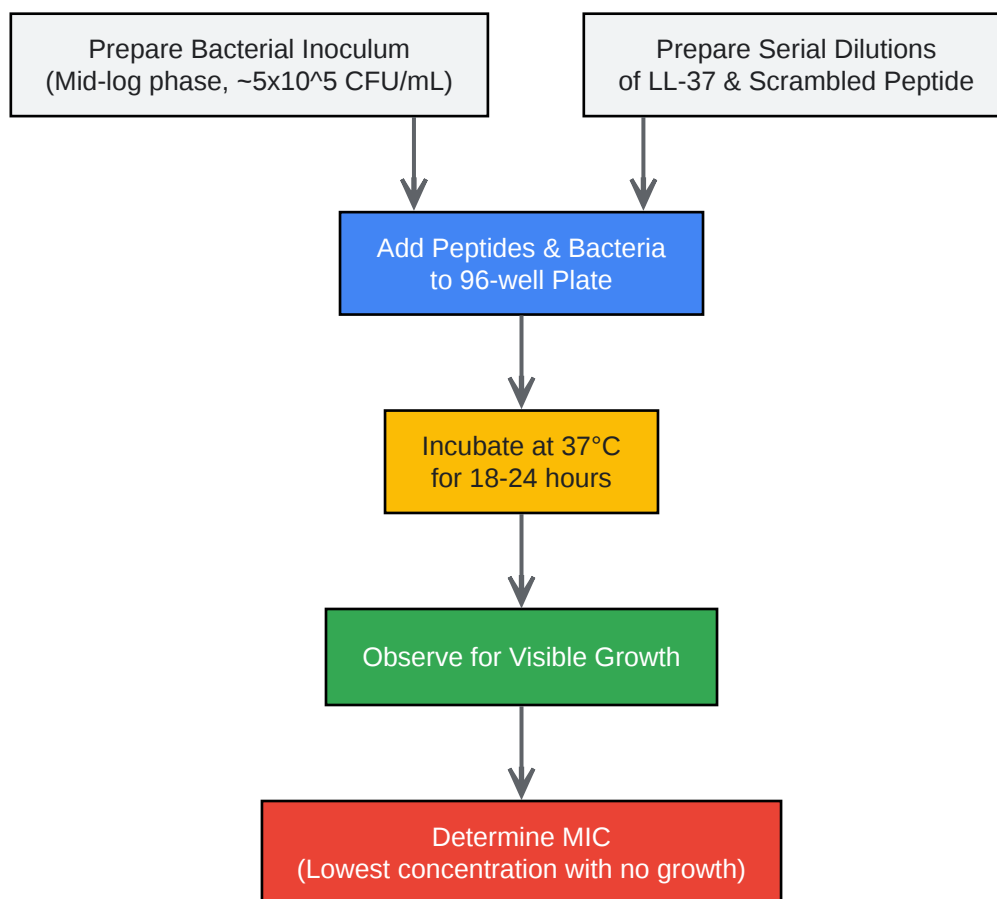

[Click to download full resolution via product page](#)

Caption: Workflow for Minimum Inhibitory Concentration (MIC) assay.

## Logical Relationship: LL-37 vs. Scrambled Peptide

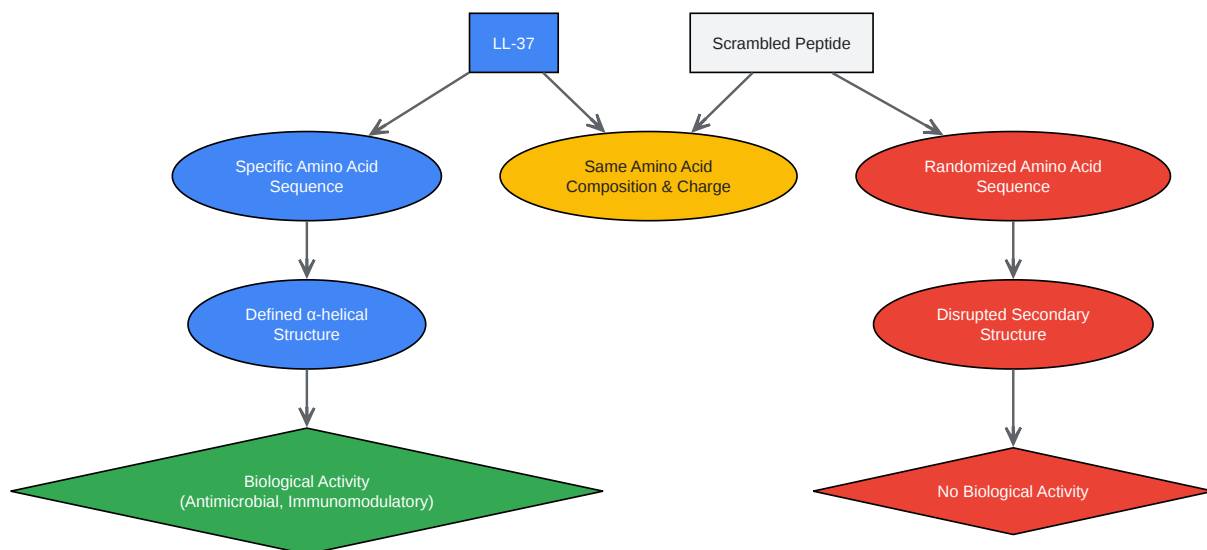

[Click to download full resolution via product page](#)

Caption: Logical relationship between LL-37 and its scrambled control.

**Need Custom Synthesis?**

BenchChem offers custom synthesis for rare earth carbides and specific isotopic labeling.

Email: [info@benchchem.com](mailto:info@benchchem.com) or [Request Quote Online](#).

## References

- 1. Antimicrobial Properties and Cytotoxicity of LL-37-Derived Synthetic Peptides to Treat Orthopedic Infections - PMC [pmc.ncbi.nlm.nih.gov]
- 2. Frontiers | The Naturally Occurring Host Defense Peptide, LL-37, and Its Truncated Mimetics KE-18 and KR-12 Have Selected Biocidal and Antibiofilm Activities Against Candida albicans, Staphylococcus aureus, and Escherichia coli In vitro [frontiersin.org]

- 3. Renovation as innovation: Repurposing human antibacterial peptide LL-37 for cancer therapy - PMC [[pmc.ncbi.nlm.nih.gov](https://pubmed.ncbi.nlm.nih.gov)]
- 4. The antimicrobial peptide LL-37 modulates the inflammatory and host defense response of human neutrophils - PMC [[pmc.ncbi.nlm.nih.gov](https://pubmed.ncbi.nlm.nih.gov)]
- 5. [researchgate.net](https://www.researchgate.net) [[researchgate.net](https://www.researchgate.net)]
- 6. Antimicrobial peptide LL-37 promotes the proliferation and invasion of skin squamous cell carcinoma by upregulating DNA-binding protein A - PMC [[pmc.ncbi.nlm.nih.gov](https://pubmed.ncbi.nlm.nih.gov)]
- 7. Treatment with LL-37 is safe and effective in enhancing healing of hard-to-heal venous leg ulcers: a randomized, placebo-controlled clinical trial - PubMed [[pubmed.ncbi.nlm.nih.gov](https://pubmed.ncbi.nlm.nih.gov)]
- 8. The antimicrobial peptide LL37 induces the migration of human pulp cells: a possible adjunct for regenerative endodontics - PubMed [[pubmed.ncbi.nlm.nih.gov](https://pubmed.ncbi.nlm.nih.gov)]
- To cite this document: BenchChem. [LL-37 vs. Scrambled Peptide: A Comparative Guide for Functional Assays]. BenchChem, [2026]. [Online PDF]. Available at: [<https://www.benchchem.com/product/b15567582/docs#ll-37-vs-scrambled-peptide-a-comparative-guide-for-functional-assays>]

---

### Disclaimer & Data Validity:

The information provided in this document is for Research Use Only (RUO) and is strictly not intended for diagnostic or therapeutic procedures. While BenchChem strives to provide accurate protocols, we make no warranties, express or implied, regarding the fitness of this product for every specific experimental setup.

**Technical Support:** The protocols provided are for reference purposes. Unsure if this reagent suits your experiment?

**Need Industrial/Bulk Grade?** [Request Custom Synthesis Quote](#)

## BenchChem

Our mission is to be the trusted global source of essential and advanced chemicals, empowering scientists and researchers to drive progress in science and industry.

### Contact

Address: 3281 E Guasti Rd

Ontario, CA 91761, United States

Phone: (601) 213-4426

Email: [info@benchchem.com](mailto:info@benchchem.com)

Contact our Ph.D. Support Team for a compatibility check