

# Application Notes and Protocols for High-Throughput siRNA Screening using Reverse Transfection

**Author:** BenchChem Technical Support Team. **Date:** April 2026

## Compound of Interest

Compound Name: *ABCA1 Human Pre-designed  
siRNA Set A*

Cat. No.: *B12432133*

[Get Quote](#)

For Researchers, Scientists, and Drug Development Professionals

## Introduction

Small interfering RNA (siRNA) has become an indispensable tool for functional genomics and target validation in drug discovery. High-throughput screening (HTS) with siRNA libraries allows for the systematic knockdown of thousands of genes to identify their roles in various biological processes. Reverse transfection is a powerful and efficient method for large-scale siRNA screening, offering significant advantages in terms of workflow simplification and automation compatibility.[1][2]

In contrast to traditional forward transfection where cells are plated a day before the introduction of transfection complexes, reverse transfection involves seeding cells directly onto pre-plated siRNA-lipid complexes.[1][2][3][4] This "all-in-one-day" procedure reduces hands-on time, minimizes plate handling, and is highly amenable to robotic automation, making it the method of choice for HTS.[1][5][6]

These application notes provide detailed protocols and guidelines for performing high-throughput siRNA screening using the reverse transfection method.

## Principle of Reverse Transfection

The key distinction between forward and reverse transfection lies in the sequence of adding the three main components: cells, siRNA, and transfection reagent.

- **Forward Transfection:** Cells are seeded in culture plates and allowed to adhere overnight. The following day, siRNA and transfection reagent are complexed and added to the cells.[\[1\]](#)  
[\[4\]](#)
- **Reverse Transfection:** The siRNA and transfection reagent are first complexed and dispensed into the wells of the assay plate. Cells are then seeded directly into these wells, initiating transfection as the cells settle and adhere.[\[1\]](#)[\[5\]](#)[\[6\]](#)

The reverse transfection workflow is particularly advantageous for HTS as it streamlines the process, reduces the number of steps, and enhances reproducibility.[\[1\]](#)[\[3\]](#)

## Experimental Workflow for High-Throughput siRNA Screening

The general workflow for a high-throughput siRNA screen using reverse transfection involves several key stages, from assay development to data analysis.

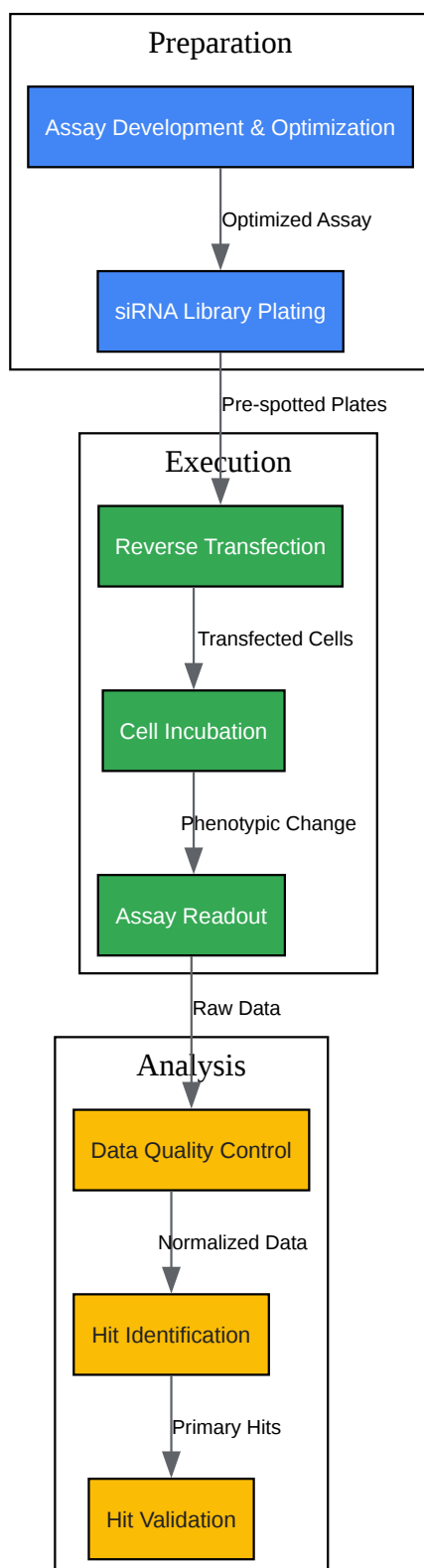

[Click to download full resolution via product page](#)

Caption: High-throughput siRNA screening workflow.

## Optimization of Reverse Transfection Conditions

Prior to initiating a large-scale screen, it is crucial to optimize transfection conditions for the specific cell line and assay being used. Key parameters to optimize include siRNA concentration, transfection reagent volume, and cell seeding density.<sup>[1][3]</sup> A matrix-based optimization approach in a 96- or 384-well plate format is recommended.

Table 1: Example Optimization Matrix for a 96-Well Plate

siRNA Concentration (nM)	Transfection Reagent Volume (µL)	Cell Seeding Density (cells/well)
5	0.1	5,000
5	0.2	5,000
5	0.3	5,000
10	0.1	10,000
10	0.2	10,000
10	0.3	10,000
20	0.1	15,000
20	0.2	15,000
20	0.3	15,000

Note: The optimal conditions will vary depending on the cell line, transfection reagent, and siRNA. It is recommended to perform a titration for each new cell line and assay.

## Detailed Protocol for Reverse Transfection in a 384-Well Plate

This protocol provides a general guideline for performing reverse transfection of siRNA in a 384-well format, suitable for high-throughput screening.

Materials:

- siRNA library plates (pre-spotted with siRNA)
- Transfection reagent (e.g., Lipofectamine RNAiMAX)
- Opti-MEM® I Reduced Serum Medium
- Complete cell culture medium (without antibiotics)
- Mammalian cell line of interest
- 384-well tissue culture plates
- Reagent reservoirs
- Multichannel pipette or automated liquid handler

#### Protocol:

- Preparation of Transfection Reagent Mixture:
  - In a sterile reservoir, dilute the transfection reagent in Opti-MEM® I medium. The optimal volume of transfection reagent should be determined from the optimization experiments.
  - Mix gently and incubate for 5-10 minutes at room temperature.
- Dispensing Transfection Reagent:
  - Using a multichannel pipette or automated liquid handler, dispense the diluted transfection reagent into each well of the 384-well plate containing the pre-spotted siRNA.
  - Incubate the plates for 10-20 minutes at room temperature to allow the formation of siRNA-lipid complexes.[5]
- Cell Seeding:
  - While the complexes are forming, harvest and count the cells.
  - Dilute the cells in complete culture medium (without antibiotics) to the optimized seeding density.

- Using a multichannel pipette or automated liquid handler, dispense the cell suspension into each well of the 384-well plate containing the siRNA-lipid complexes.
- Incubation:
  - Incubate the plates at 37°C in a CO2 incubator for 24-72 hours. The incubation time will depend on the specific assay and the time required to observe a phenotype.[5]
- Assay Readout:
  - After incubation, perform the specific cellular assay to measure the phenotype of interest (e.g., cell viability, reporter gene expression, or high-content imaging).

Table 2: Recommended Reagent Volumes for Different Plate Formats

Plate Format	siRNA (pmol)	Diluted Transfection Reagent (µL)	Cell Suspension (µL)	Final Volume (µL)
96-well	1-5	20	80	100
384-well	0.5-2	10	30	40

## Quality Control in High-Throughput Screening

Robust quality control (QC) is essential to ensure the reliability and reproducibility of HTS data. This involves the use of appropriate controls on each assay plate.

Controls for siRNA Screening:

- Negative Controls:
  - Non-targeting siRNA: An siRNA sequence that does not target any known gene in the organism being studied. This control helps to assess non-specific effects of the siRNA delivery system.[7]
  - Mock Transfection: Cells treated with the transfection reagent only (no siRNA). This control measures the toxicity of the transfection reagent itself.

- Positive Controls:
  - Housekeeping Gene siRNA: An siRNA targeting an essential gene (e.g., GAPDH, PPIB) that, when knocked down, produces a robust and easily measurable phenotype (e.g., cell death). This control is used to monitor transfection efficiency.[8]
  - Assay-Specific Positive Control: A known gene that, when silenced, is expected to produce the phenotype of interest. This validates the assay's ability to detect true hits.[7]

A widely used statistical parameter for assessing the quality of an HTS assay is the Z'-factor.[9] It measures the statistical effect size and the separation between the positive and negative control signals.

Z'-Factor Calculation:

$$Z' = 1 - (3 * (\sigma_p + \sigma_n)) / |\mu_p - \mu_n|$$

Where:

- $\mu_p$  = mean of the positive control
- $\sigma_p$  = standard deviation of the positive control
- $\mu_n$  = mean of the negative control
- $\sigma_n$  = standard deviation of the negative control

Table 3: Interpretation of Z'-Factor Values

Z'-Factor	Assay Quality
> 0.5	Excellent assay
0 to 0.5	Acceptable assay, may require optimization
< 0	Unacceptable assay

## Data Analysis Workflow

The analysis of high-throughput siRNA screening data involves a multi-step process to identify statistically significant "hits."

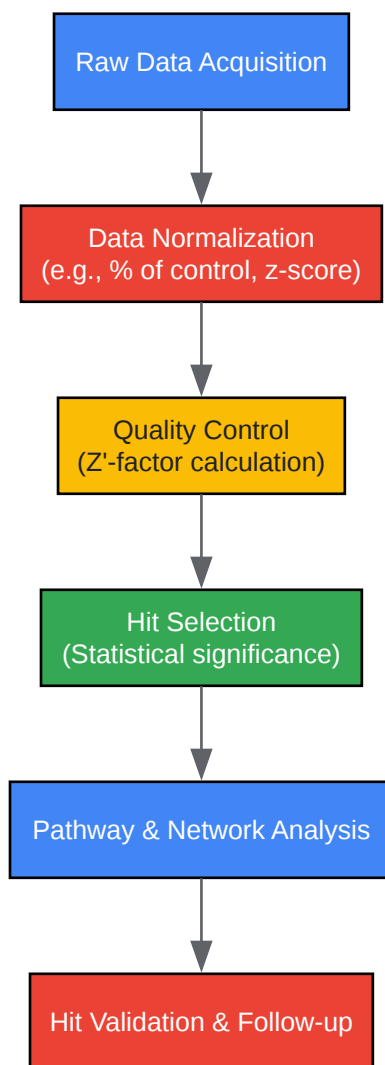

[Click to download full resolution via product page](#)

### Need Custom Synthesis?

BenchChem offers custom synthesis for rare earth carbides and specific isotopic labeling.

Email: [info@benchchem.com](mailto:info@benchchem.com) or [Request Quote Online](#).

## References

- [1. Our top tech tips for optimizing your reverse transfection for CRISPR and siRNA experiments \[horizondiscovery.com\]](#)
- [2. Forward Transfection or Reverse Transfection? | Transfection Reagents | Cell Lines, In Vivo | Altogen Biosystems \[altogen.com\]](#)
- [3. Top Ten Ways to Optimize siRNA Delivery in Cultured Cells | Thermo Fisher Scientific - TW \[thermofisher.com\]](#)
- [4. quora.com \[quora.com\]](#)
- [5. RNAiMAX Reverse Transfections Lipofectamine | Thermo Fisher Scientific - TW \[thermofisher.com\]](#)
- [6. documents.thermofisher.com \[documents.thermofisher.com\]](#)
- [7. siRNA Screening Overview — Target Discovery Institute \[tdi.ox.ac.uk\]](#)
- [8. horizondiscovery.com \[horizondiscovery.com\]](#)
- [9. Statistical Methods for Analysis of High-Throughput RNA Interference Screens - PMC \[pmc.ncbi.nlm.nih.gov\]](#)
- [To cite this document: BenchChem. \[Application Notes and Protocols for High-Throughput siRNA Screening using Reverse Transfection\]. BenchChem, \[2026\]. \[Online PDF\]. Available at: \[https://www.benchchem.com/product/b12432133/docs#application-notes-and-protocols-for-high-throughput-sirna-screening-using-reverse-transfection\]](#)

---

### Disclaimer & Data Validity:

The information provided in this document is for Research Use Only (RUO) and is strictly not intended for diagnostic or therapeutic procedures. While BenchChem strives to provide accurate protocols, we make no warranties, express or implied, regarding the fitness of this product for every specific experimental setup.

**Technical Support:** The protocols provided are for reference purposes. Unsure if this reagent suits your experiment?

**Need Industrial/Bulk Grade?** [Request Custom Synthesis Quote](#)

# BenchChem

Our mission is to be the trusted global source of essential and advanced chemicals, empowering scientists and researchers to drive progress in science and industry.

## Contact

Address: 3281 E Guasti Rd

Ontario, CA 91761, United States

Phone: (601) 213-4426

Email: [info@benchchem.com](mailto:info@benchchem.com)

[Contact our Ph.D. Support Team for a compatibility check](#)