

# Application Notes and Protocols for Assessing FPI-1523 Sodium PBP2 Inhibition

**Author:** BenchChem Technical Support Team. **Date:** April 2026

## Compound of Interest

Compound Name: *FPI-1523 sodium*

Cat. No.: *B15567163*

[Get Quote](#)

For Researchers, Scientists, and Drug Development Professionals

## Introduction

Penicillin-binding proteins (PBPs) are essential bacterial enzymes that catalyze the final steps of peptidoglycan synthesis, a critical component of the bacterial cell wall.[1] These enzymes are the primary targets of  $\beta$ -lactam antibiotics. **FPI-1523 sodium** is a novel  $\beta$ -lactamase inhibitor that has been shown to exhibit preferential inhibition of Penicillin-Binding Protein 2 (PBP2).[2] This document provides detailed application notes and protocols for assessing the inhibition of PBP2 by **FPI-1523 sodium**, facilitating research and development of new antibacterial therapies.

The methods described herein are foundational for characterizing the biochemical potency of **FPI-1523 sodium** and similar compounds, determining their mechanism of action, and providing crucial data for structure-activity relationship (SAR) studies. The primary techniques covered are fluorescence-based competition assays, which are widely used for their sensitivity, specificity, and adaptability to high-throughput screening.

## Signaling Pathway of PBP2 Inhibition

PBP2 is a key transpeptidase involved in the elongation of the peptidoglycan cell wall in many bacterial species. Inhibition of PBP2 by a  $\beta$ -lactam antibiotic, or a  $\beta$ -lactamase inhibitor with affinity for PBP2 like FPI-1523, disrupts the cross-linking of peptidoglycan chains. This disruption weakens the cell wall, leading to morphological changes, cessation of cell growth, and ultimately cell lysis.

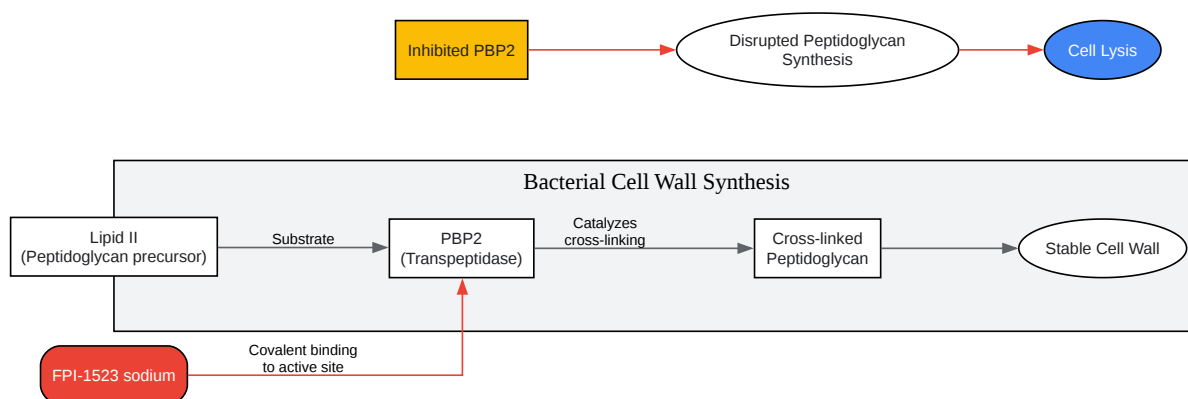

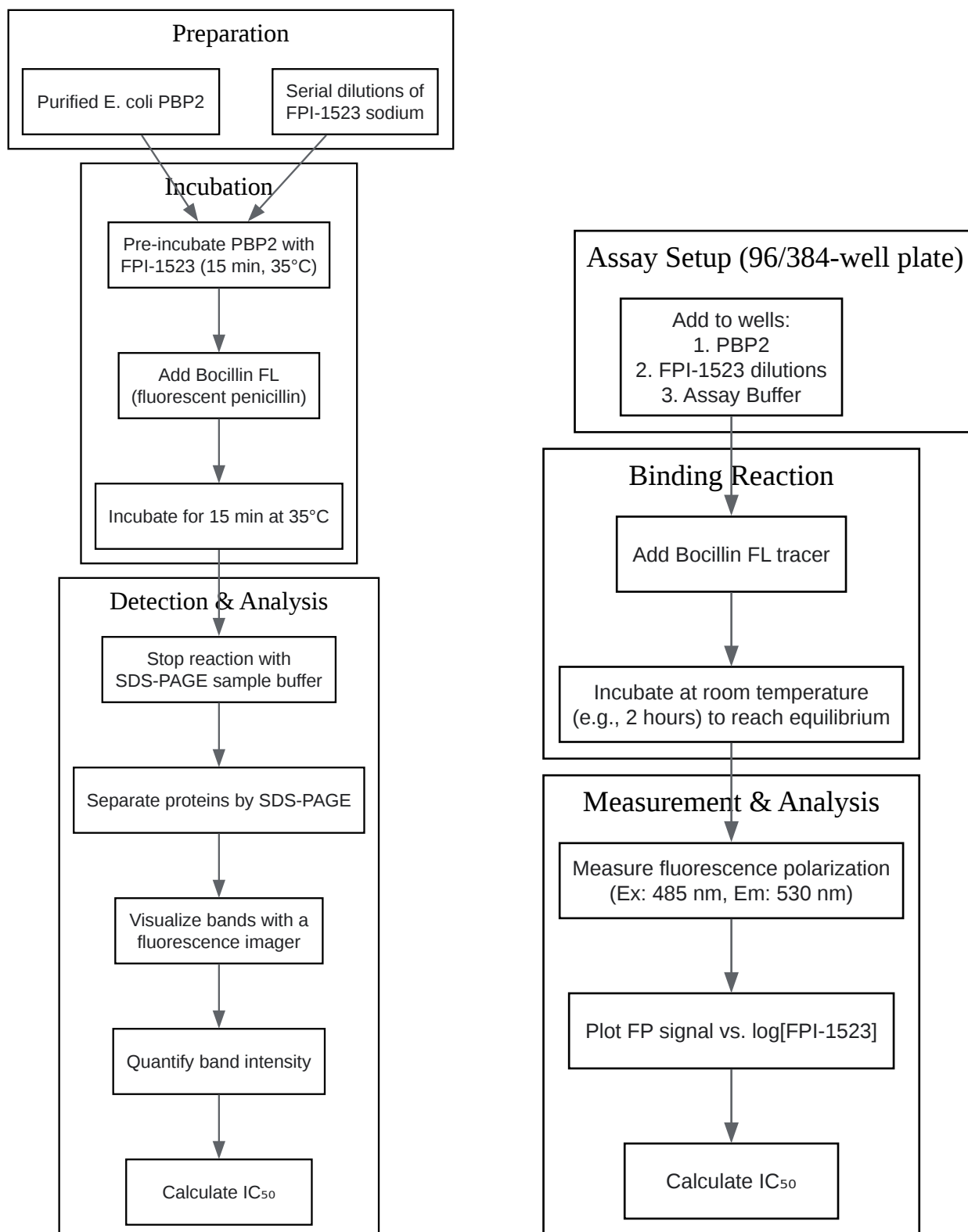

[Click to download full resolution via product page](#)

### Need Custom Synthesis?

BenchChem offers custom synthesis for rare earth carbides and specific isotopic labeling.

Email: [info@benchchem.com](mailto:info@benchchem.com) or [Request Quote Online](#).

## References

- [1. benchchem.com \[benchchem.com\]](https://www.benchchem.com)
- [2. Penicillin-binding protein \(PBP\) inhibitor development: A 10-year chemical perspective - PMC \[pmc.ncbi.nlm.nih.gov\]](https://pubmed.ncbi.nlm.nih.gov/)
- To cite this document: BenchChem. [Application Notes and Protocols for Assessing FPI-1523 Sodium PBP2 Inhibition]. BenchChem, [2026]. [Online PDF]. Available at: [\[https://www.benchchem.com/product/b15567163/docs#application-notes-and-protocols-for-assessing-fpi-1523-sodium-pbp2-inhibition\]](https://www.benchchem.com/product/b15567163/docs#application-notes-and-protocols-for-assessing-fpi-1523-sodium-pbp2-inhibition)

### Disclaimer & Data Validity:

The information provided in this document is for Research Use Only (RUO) and is strictly not intended for diagnostic or therapeutic procedures. While BenchChem strives to provide accurate protocols, we make no warranties, express or implied, regarding the fitness of this product for every specific experimental setup.

**Technical Support:** The protocols provided are for reference purposes. Unsure if this reagent suits your experiment?

**Need Industrial/Bulk Grade?** [Request Custom Synthesis Quote](#)

## BenchChem

Our mission is to be the trusted global source of essential and advanced chemicals, empowering scientists and researchers to drive progress in science and industry.

### Contact

Address: 3281 E Guasti Rd  
Ontario, CA 91761, United States  
Phone: (601) 213-4426  
Email: [info@benchchem.com](mailto:info@benchchem.com)

Contact our Ph.D. Support Team for a compatibility check