

Mass Spectrometry of Emerimicin III: A Technical Guide

Author: BenchChem Technical Support Team. **Date:** April 2026

Compound of Interest

Compound Name: *Emerimicin III*

Cat. No.: *B15566907*

[Get Quote](#)

For Researchers, Scientists, and Drug Development Professionals

This guide provides an in-depth technical overview of the mass spectrometric analysis of **Emerimicin III**, a peptaibol antibiotic. It covers detailed experimental protocols, fragmentation analysis, and data presentation to aid in the research and development of this class of compounds.

Introduction to Emerimicin III

Emerimicin III is a linear 15-residue peptaibol antibiotic belonging to a class of fungal metabolites known for their ability to form voltage-dependent ion channels in lipid membranes. Structurally, it is characterized by a high content of the non-proteinogenic amino acid α -aminoisobutyric acid (Aib), an N-terminal acetyl group, and a C-terminal amino alcohol, Phenylalaninol (Phol). The molecular weight of **Emerimicin III** is 1558 Da. Its amino acid sequence is closely related to Emerimicin IV, with the key difference being the substitution of an Aib residue with an Alanine (Ala) residue in **Emerimicin III**.

The complete amino acid sequence of **Emerimicin III** is determined to be:

Ac-Phe-Aib-Aib-Aib-Val-Gly-Leu-Aib-Aib-Hyp-Gln-Iva-Hyp-Ala-Phol

Experimental Protocols for Mass Spectrometric Analysis

The following section outlines a comprehensive protocol for the analysis of **Emerimicin III** using liquid chromatography coupled with tandem mass spectrometry (LC-MS/MS), a standard and powerful technique for the characterization of such peptides.

Sample Preparation

Effective sample preparation is crucial for obtaining high-quality mass spectra.

- **Solubilization:** Dissolve the purified **Emerimicin III** sample in a suitable organic solvent such as methanol or acetonitrile to a final concentration of 1 mg/mL to create a stock solution.
- **Working Solution:** Prepare a working solution by diluting the stock solution with the initial mobile phase solvent (e.g., 95% water, 5% acetonitrile, 0.1% formic acid) to a final concentration of 1-10 µg/mL.
- **Centrifugation:** Centrifuge the working solution at high speed (e.g., 14,000 x g) for 10 minutes to pellet any insoluble material.
- **Transfer:** Carefully transfer the supernatant to an appropriate autosampler vial for LC-MS/MS analysis.

Liquid Chromatography (LC)

Chromatographic separation is employed to purify the sample online before introduction into the mass spectrometer.

- **LC System:** A high-performance liquid chromatography (HPLC) or ultra-high-performance liquid chromatography (UHPLC) system.
- **Column:** A reversed-phase C18 column (e.g., 2.1 mm x 100 mm, 1.8 µm particle size) is suitable for separating peptaibols.
- **Mobile Phase A:** 0.1% formic acid in water.
- **Mobile Phase B:** 0.1% formic acid in acetonitrile.

- Gradient: A linear gradient from 5% to 95% Mobile Phase B over 30 minutes.
- Flow Rate: 0.3 mL/min.
- Column Temperature: 40 °C.
- Injection Volume: 5 µL.

Mass Spectrometry (MS)

Tandem mass spectrometry is used for the determination of the molecular weight and for sequencing the peptide through fragmentation analysis.

- Mass Spectrometer: A high-resolution mass spectrometer such as a Quadrupole Time-of-Flight (Q-TOF) or an Orbitrap instrument equipped with an electrospray ionization (ESI) source.
- Ionization Mode: Positive ion mode is typically used for peptides as they readily form protonated molecules.
- Capillary Voltage: 3.5 - 4.5 kV.
- Source Temperature: 120 - 150 °C.
- Desolvation Gas Flow: 600 - 800 L/hr.
- MS1 Scan Range: m/z 100 - 2000.
- Tandem MS (MS/MS):
 - Activation Method: Collision-Induced Dissociation (CID) or Higher-energy Collisional Dissociation (HCD).
 - Precursor Ion Selection: Isolate the protonated molecular ion of **Emerimicin III** ($[M+H]^+$ at m/z 1559.9). The sodium adduct ($[M+Na]^+$ at m/z 1581.9) may also be targeted.
 - Collision Energy: A stepped or ramped collision energy (e.g., 20-50 eV) is often used to generate a rich fragmentation spectrum.

Data Presentation: Fragmentation Analysis

Upon collision-induced dissociation, peptides like **Emerimicin III** predominantly fragment along the peptide backbone, yielding b- and y-type ions. The b-ions contain the N-terminus, while the y-ions contain the C-terminus. The following table summarizes the theoretical monoisotopic m/z values for the singly charged b- and y-ions of **Emerimicin III**.

Cleavage Site	Amino Acid	b-ion (m/z)	y-ion (m/z)
1	Ac-Phe	190.0863	1559.9200
2	Aib	275.1391	1370.8337
3	Aib	360.1919	1285.7809
4	Aib	445.2447	1200.7281
5	Val	544.3131	1115.6753
6	Gly	601.3341	1016.6069
7	Leu	714.4182	959.5859
8	Aib	799.4710	846.5018
9	Aib	884.5238	761.4490
10	Hyp	981.5766	676.3962
11	Gln	1109.6355	579.3434
12	Iva	1208.7039	451.2845
13	Hyp	1305.7567	352.2161
14	Ala	1376.8044	255.1633
15	Phol	1511.8633	184.1157

Visualizations

Experimental Workflow

The following diagram illustrates the general workflow for the LC-MS/MS analysis of **Emerimicin III**.



[Click to download full resolution via product page](#)

Caption: General workflow for the LC-MS/MS analysis of **Emerimicin III**.

Fragmentation Pathway

The fragmentation of **Emerimicin III** primarily occurs at the peptide bonds, leading to the formation of b- and y-ion series. This process allows for the sequential determination of the amino acid residues.

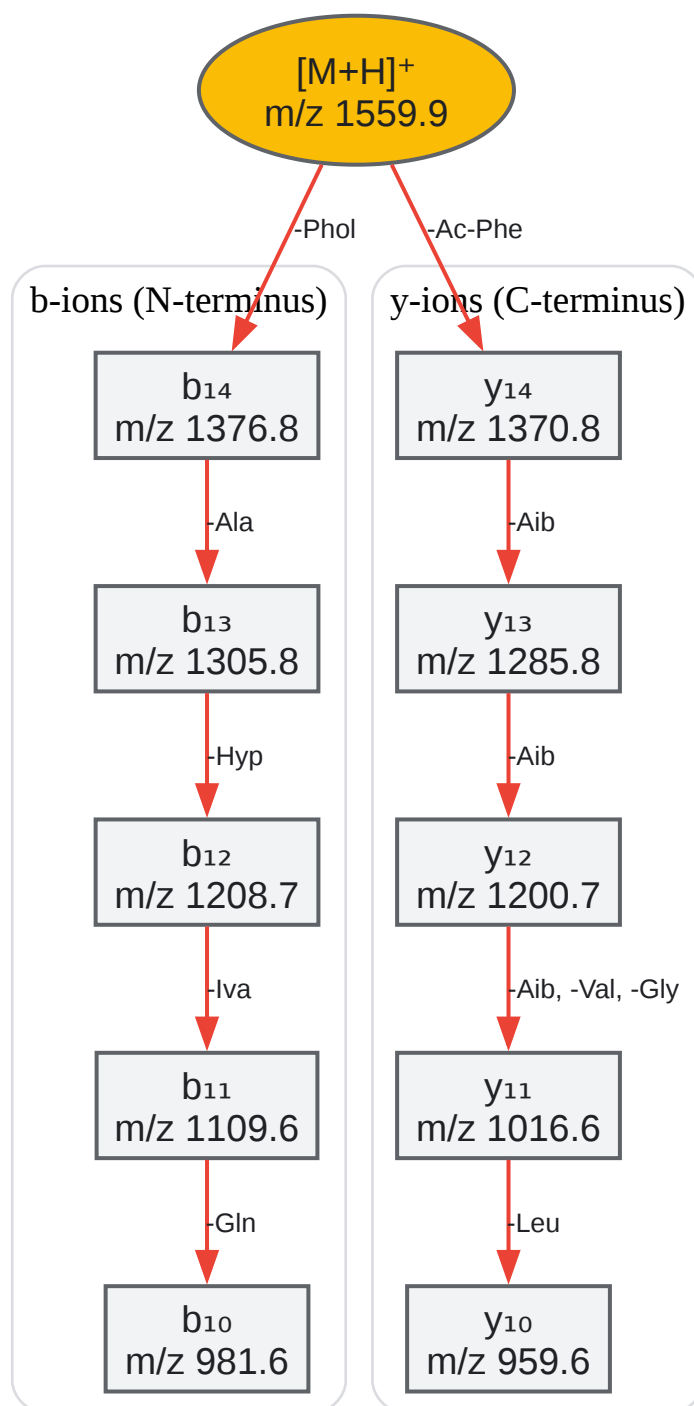

[Click to download full resolution via product page](#)

Caption: Simplified fragmentation pathway of **Emerimicin III** showing the generation of key b and y ions.

- To cite this document: BenchChem. [Mass Spectrometry of Emerimicin III: A Technical Guide]. BenchChem, [2026]. [Online PDF]. Available at:

[<https://www.benchchem.com/product/b15566907/docs#mass-spectrometry-of-emerimicin-iii-a-technical-guide>]

Disclaimer & Data Validity:

The information provided in this document is for Research Use Only (RUO) and is strictly not intended for diagnostic or therapeutic procedures. While BenchChem strives to provide accurate protocols, we make no warranties, express or implied, regarding the fitness of this product for every specific experimental setup.

Technical Support: The protocols provided are for reference purposes. Unsure if this reagent suits your experiment?

Need Industrial/Bulk Grade? [Request Custom Synthesis Quote](#)

BenchChem

Our mission is to be the trusted global source of essential and advanced chemicals, empowering scientists and researchers to drive progress in science and industry.

Contact

Address: 3281 E Guasti Rd
Ontario, CA 91761, United States
Phone: (601) 213-4426
Email: info@benchchem.com

[Contact our Ph.D. Support Team for a compatibility check](#)