

# Validating the Sec61-Targeting Mechanism of Coibamide A: A Comparative Guide

**Author:** BenchChem Technical Support Team. **Date:** April 2026

## Compound of Interest

Compound Name:	Coibamide A
CAS No.:	1029227-48-2
Cat. No.:	B15565077

[Get Quote](#)

The Sec61 translocon, the primary channel for protein translocation into the endoplasmic reticulum (ER), has emerged as a significant target for novel therapeutics, particularly in oncology. A host of natural products have been identified that inhibit this crucial cellular process, each with distinct mechanisms and potential therapeutic windows. Among these, **Coibamide A** (CbA), a potent marine-derived depsipeptide, has garnered considerable interest for its unique cytotoxic profile.<sup>[1][2][3][4][5]</sup> This guide provides a comparative analysis of the experimental validation of **Coibamide A**'s Sec61-targeting mechanism, contrasting it with other well-characterized Sec61 inhibitors.

## Coibamide A: A Non-Selective Inhibitor of Protein Translocation

**Coibamide A** exerts its potent cytotoxic effects by directly targeting the alpha subunit of the Sec61 complex (Sec61 $\alpha$ ). This interaction leads to a broad, substrate-nonspecific inhibition of protein import into the ER. Consequently, the biogenesis of a wide range of secretory and integral membrane proteins is halted, leading to cellular stress and apoptosis. The direct interaction with Sec61 $\alpha$  has been validated through several key experiments, which are detailed in the protocols section of this guide.

One of the most compelling pieces of evidence for **Coibamide A**'s mechanism comes from studies of resistance-conferring mutations. While mutations like R66I in Sec61 $\alpha$  grant strong resistance to other known Sec61 inhibitors, they only have a mild effect on **Coibamide A**'s activity. Conversely, the S71P mutation in Sec61 $\alpha$  confers specific resistance to **Coibamide A**. This suggests that although **Coibamide A** binds to a luminal cavity on Sec61 $\alpha$  that partially overlaps with other inhibitors, its precise binding mode is distinct.

## Comparison with Alternative Sec61 Inhibitors

To better understand the unique properties of **Coibamide A**, it is useful to compare it with other natural product inhibitors of Sec61, such as Apratoxin A, Ipomoeassin F, and Mycalolide B.

- **Apratoxin A**: Like **Coibamide A**, Apratoxin A is a marine cyanobacterial product that inhibits co-translational translocation. However, the differential effects of Sec61 $\alpha$  mutations indicate a different binding interaction.
- **Ipomoeassin F**: This plant-derived cytotoxin also targets Sec61 $\alpha$  to inhibit protein translocation. It is a potent, broad-spectrum inhibitor, similar in action to **Coibamide A**.
- **Mycalolide B**: Isolated from a marine sponge, Mycalolide B was initially identified as an inhibitor of actomyosin ATPase but has since been shown to also impact Sec61-mediated processes. Mycolactone, a structurally different macrolide, is a more extensively studied potent and broad-spectrum Sec61 inhibitor.

## Comparative Data

The following tables summarize the quantitative data comparing the activity of **Coibamide A** with other Sec61 inhibitors.

Table 1: Cytotoxic Potency of Sec61 Inhibitors in Human Cancer Cell Lines

Compound	Cell Line	IC50 (nM)
Coibamide A	HCT116	~5-10
MDA-MB-231	~1-5	
U87-MG	~1-5	
Apratoxin A	HCT116	~1-5
Ipomoeassin F	A2780	36
Mycolactone	Jurkat T cells	<1

Note: IC50 values can vary between studies and experimental conditions. The values presented here are approximate ranges based on available literature.

Table 2: Effect of Sec61 $\alpha$  Mutations on Inhibitor Sensitivity

Sec61 $\alpha$ Mutation	Coibamide A	Apratoxin A	Other Inhibitors
R66I	Mild Resistance	Strong Resistance	Strong Resistance
S71P	CbA-Resistant	Sensitive	Sensitive

This table highlights the distinct binding mode of **Coibamide A** compared to other Sec61 inhibitors.

## Experimental Protocols

### Photoaffinity Labeling with a Coibamide A Probe

This method was used to identify the direct cellular target of **Coibamide A**.

- **Probe Synthesis:** An optimized photoaffinity probe of **Coibamide A** (photo-CbA) is synthesized. This probe is isosteric to the parent compound and contains a photo-reactive group and a clickable tag (e.g., an alkyne).
- **Cellular Treatment:** Human cells (e.g., HCT116) are incubated with photo-CbA in the presence or absence of a surplus of unmodified **Coibamide A** (as a competitor).

- **UV Cross-linking:** The cells are exposed to UV light to induce covalent cross-linking of the photo-reactive group to its binding partner.
- **Cell Lysis and Click Chemistry:** The cells are lysed, and the alkyne tag on the cross-linked probe is conjugated to a reporter molecule (e.g., a fluorescent dye or biotin) via a click reaction.
- **Analysis:** The labeled proteins are separated by SDS-PAGE and visualized. The protein band that is specifically labeled by photo-CbA and competed off by excess **Coibamide A** is identified as the target. This band was identified as Sec61 $\alpha$ .

## In Vitro Protein Translocation Assay

This assay confirms the inhibitory effect of **Coibamide A** on Sec61-mediated protein import into the ER.

- **System Setup:** A cell-free system is prepared containing rabbit reticulocyte lysate for in vitro translation, canine pancreatic rough microsomes (as a source of Sec61), and a plasmid encoding a model secretory protein (e.g., preprolactin).
- **In Vitro Transcription and Translation:** The plasmid is transcribed and translated in the presence of [<sup>35</sup>S]-methionine to produce a radiolabeled precursor protein.
- **Translocation Reaction:** The translation mix is incubated with the microsomes in the presence of **Coibamide A** or a vehicle control.
- **Analysis:** Successful translocation of the protein into the microsomes results in the cleavage of its signal peptide, leading to a faster-migrating band on SDS-PAGE. The inhibition of this process by **Coibamide A** is quantified by autoradiography.

## Visualizing Mechanisms and Workflows

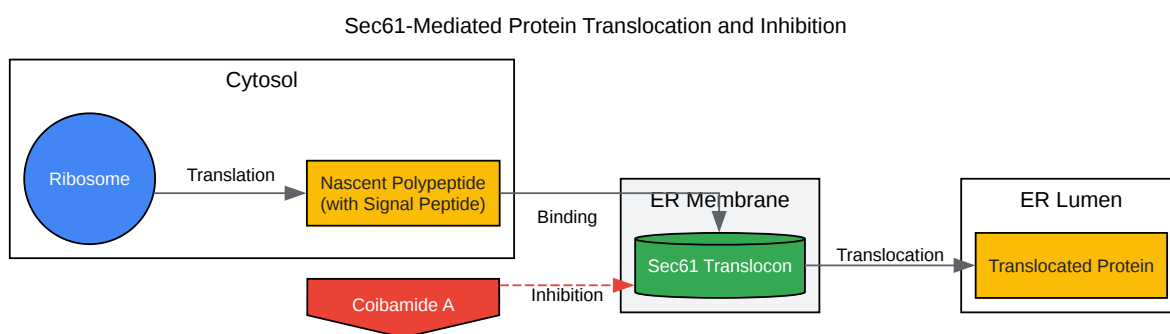

[Click to download full resolution via product page](#)

Caption: Sec61-mediated protein translocation and its inhibition by **Coibamide A**.

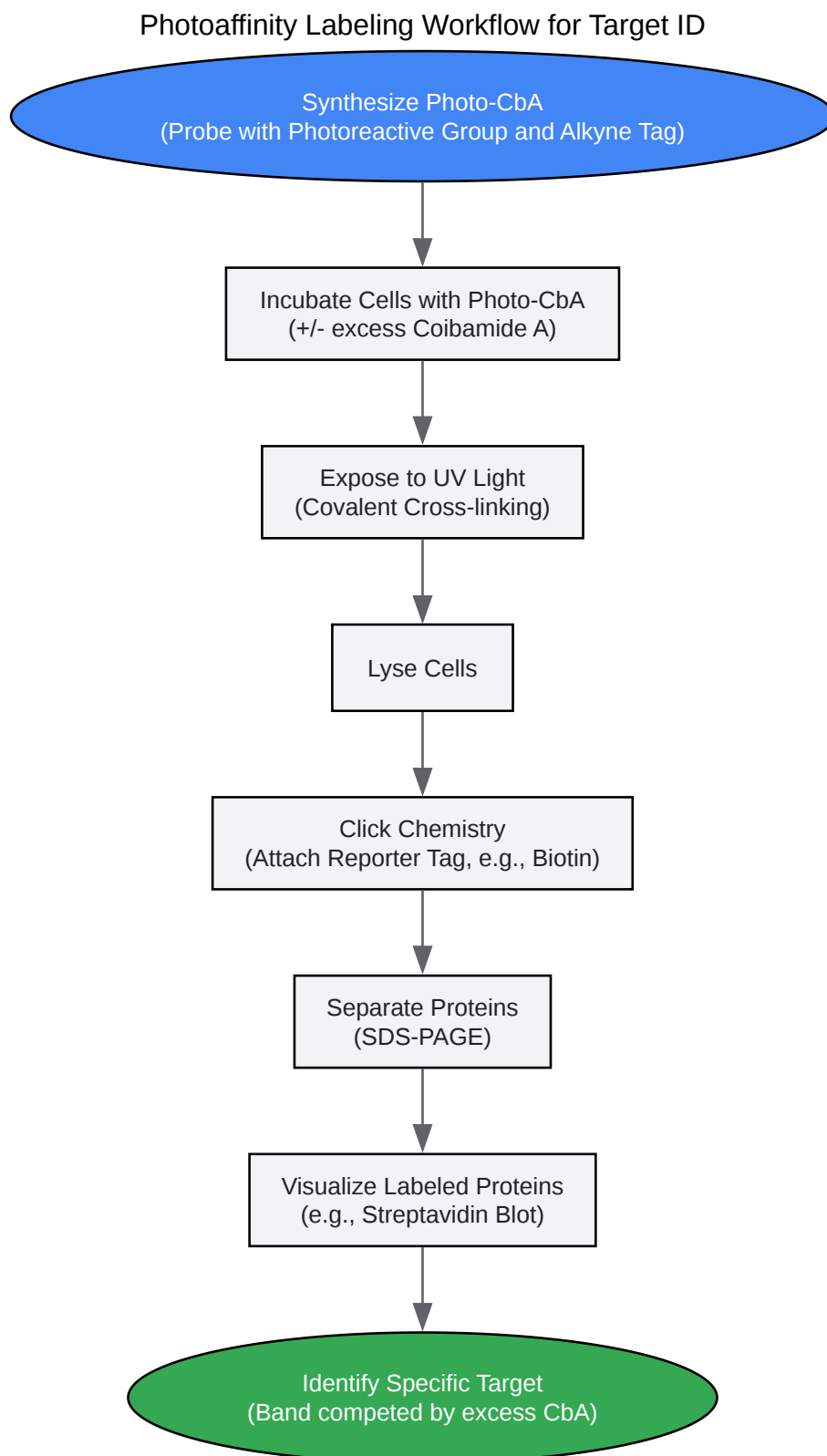

[Click to download full resolution via product page](#)

Caption: Experimental workflow for identifying the cellular target of **Coibamide A**.

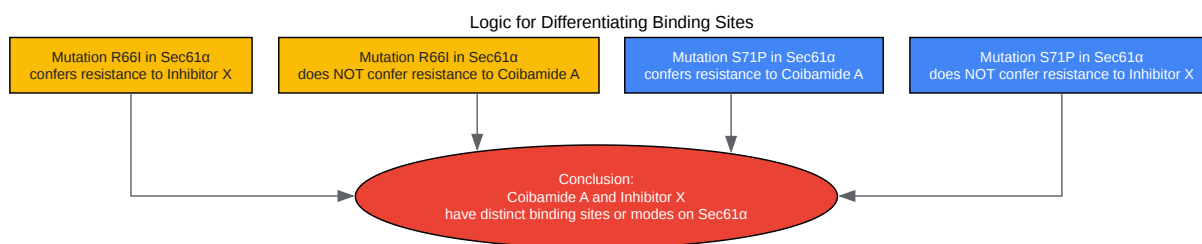

[Click to download full resolution via product page](#)

Caption: Differentiating binding sites via resistance mutation analysis.

### Need Custom Synthesis?

BenchChem offers custom synthesis for rare earth carbides and specific isotopic labeling.

Email: [info@benchchem.com](mailto:info@benchchem.com) or [Request Quote Online](#).

## References

- 1. [chemrxiv.org](https://chemrxiv.org) [chemrxiv.org]
- 2. [researchgate.net](https://researchgate.net) [researchgate.net]
- 3. Coibamide A Targets Sec61 to Prevent Biogenesis of Secretory and Membrane Proteins - PubMed [pubmed.ncbi.nlm.nih.gov]
- 4. [pubs.acs.org](https://pubs.acs.org) [pubs.acs.org]
- 5. Coibamide A, a natural lariat depsipeptide, inhibits VEGFA/VEGFR2 expression and suppresses tumor growth in glioblastoma xenografts - PubMed [pubmed.ncbi.nlm.nih.gov]
- To cite this document: BenchChem. [Validating the Sec61-Targeting Mechanism of Coibamide A: A Comparative Guide]. BenchChem, [2026]. [Online PDF]. Available at: [https://www.benchchem.com/product/b15565077/docs#validating-the-sec61-targeting-mechanism-of-coibamide-a-a-comparative-guide]

### Disclaimer & Data Validity:

The information provided in this document is for Research Use Only (RUO) and is strictly not intended for diagnostic or therapeutic procedures. While BenchChem strives to provide accurate protocols, we make no warranties, express or implied, regarding the fitness of this product for every specific experimental setup.

**Technical Support:** The protocols provided are for reference purposes. Unsure if this reagent suits your experiment?

**Need Industrial/Bulk Grade?** [Request Custom Synthesis Quote](#)

## BenchChem

Our mission is to be the trusted global source of essential and advanced chemicals, empowering scientists and researchers to drive progress in science and industry.

### Contact

Address: 3281 E Guasti Rd  
Ontario, CA 91761, United States  
Phone: (601) 213-4426  
Email: [info@benchchem.com](mailto:info@benchchem.com)

[Contact our Ph.D. Support Team for a compatibility check](#)