

Total Synthesis of Dienomyacin A and its Analogs: Application Notes and Protocols

Author: BenchChem Technical Support Team. **Date:** April 2026

Compound of Interest

Compound Name: *Dienomyacin A*

Cat. No.: *B15565119*

[Get Quote](#)

For Researchers, Scientists, and Drug Development Professionals

Introduction

Dienomyacin A is a naturally occurring piperidine alkaloid characterized by a dienyl side chain. While the total synthesis of **Dienomyacin A** has not been extensively reported, the synthesis of its close structural analog, (+)-Dienomyacin C, has been successfully achieved. This document provides a detailed overview of the synthetic strategy for (+)-Dienomyacin C as reported by Yokoyama et al., which serves as a valuable blueprint for the synthesis of **Dienomyacin A** and its other analogs.^[1] Additionally, this document touches upon the general biological activities of piperidine-containing natural products, as specific mechanistic studies on **Dienomyacin A** or C are limited in the current scientific literature.

Retrosynthetic Analysis of Dienomyacin C

The synthetic approach to (+)-Dienomyacin C hinges on a convergent strategy, assembling the key structural fragments—the substituted piperidine core and the dienyl side chain—in a stereocontrolled manner. The retrosynthesis reveals the key bond disconnections and the strategic intermediates required for the total synthesis.

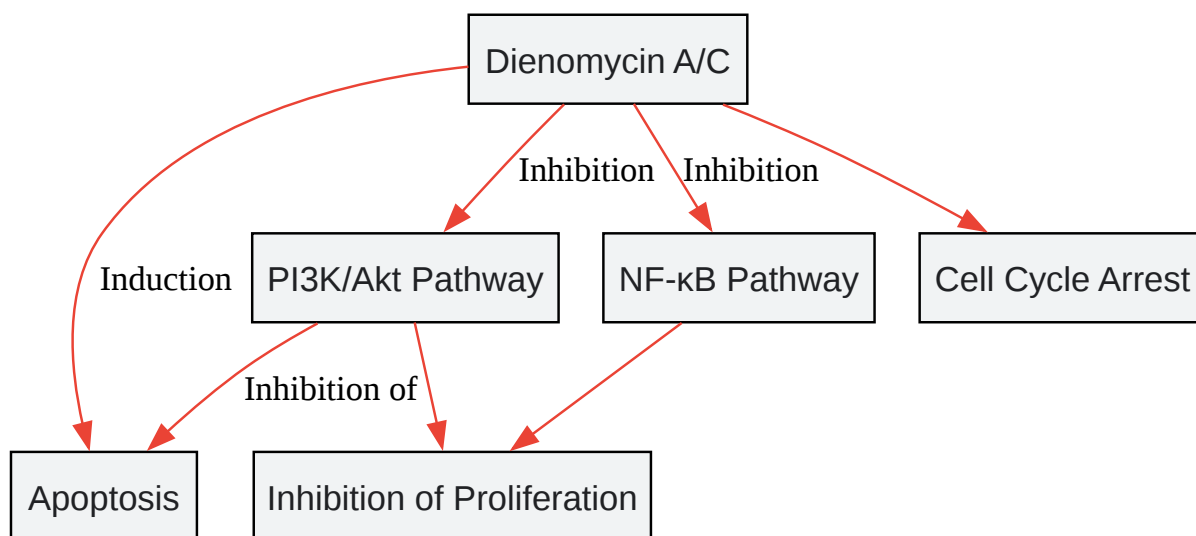
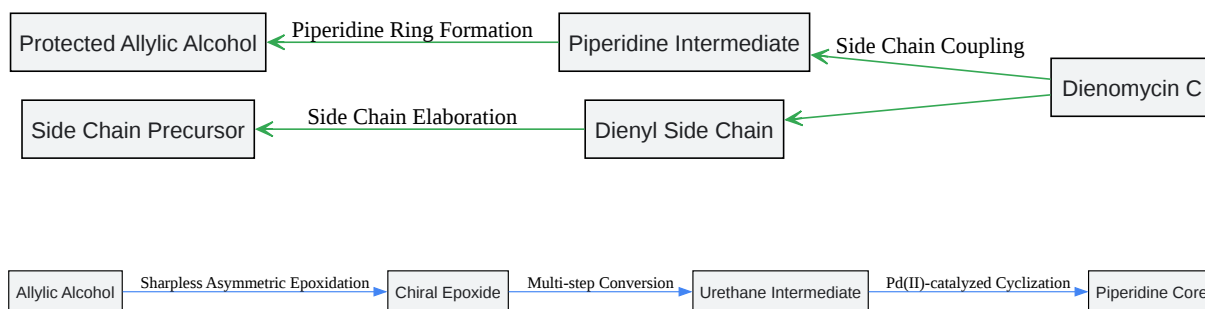

[Click to download full resolution via product page](#)

Need Custom Synthesis?

BenchChem offers custom synthesis for rare earth carbides and specific isotopic labeling.

Email: info@benchchem.com or [Request Quote Online](#).

References

- 1. [researchgate.net](https://www.researchgate.net) [researchgate.net]
- To cite this document: BenchChem. [Total Synthesis of Dienomycin A and its Analogs: Application Notes and Protocols]. BenchChem, [2026]. [Online PDF]. Available at: <https://www.benchchem.com/product/b15565119/docs#total-synthesis-of-dienomycin-a-and-its-analogs-application-notes-and-protocols>

Disclaimer & Data Validity:

The information provided in this document is for Research Use Only (RUO) and is strictly not intended for diagnostic or therapeutic procedures. While BenchChem strives to provide accurate protocols, we make no warranties, express or implied, regarding the fitness of this product for every specific experimental setup.

Technical Support: The protocols provided are for reference purposes. Unsure if this reagent suits your experiment?

Need Industrial/Bulk Grade? [Request Custom Synthesis Quote](#)

BenchChem

Our mission is to be the trusted global source of essential and advanced chemicals, empowering scientists and researchers to drive progress in science and industry.

Contact

Address: 3281 E Guasti Rd
Ontario, CA 91761, United States
Phone: (601) 213-4426
Email: info@benchchem.com

[Contact our Ph.D. Support Team for a compatibility check](#)