

The Azide Group: A Locus of Reactivity in Click Chemistry for Bioconjugation

Author: BenchChem Technical Support Team. **Date:** April 2026

Compound of Interest

Compound Name: Azido-PEG8-Amido-Val-Cit-PAB

Cat. No.: B15565451

[Get Quote](#)

An In-depth Technical Guide for Researchers, Scientists, and Drug Development Professionals

In the landscape of modern bioconjugation, the azide group has emerged as a cornerstone functional group, largely due to its central role in "click chemistry." Its unique combination of stability, small size, and specific reactivity has empowered researchers to construct complex biomolecular architectures with unprecedented precision and efficiency. This technical guide delves into the core function of the azide group in bioconjugation, with a particular focus on the two principal modalities of azide-alkyne cycloaddition: the Copper(I)-Catalyzed Azide-Alkyne Cycloaddition (CuAAC) and the Strain-Promoted Azide-Alkyne Cycloaddition (SPAAC).

The Azide: A Bioorthogonal Handle

The azide moiety ($-N_3$) is an ideal functional group for bioconjugation due to its bioorthogonality. This means that it is largely unreactive with the vast majority of functional groups found in biological systems, such as amines, carboxyls, and thiols, thus preventing unwanted side reactions.[1][2] Its small size also minimizes potential steric hindrance or perturbation of the biomolecule's structure and function.[3] The azide group is relatively stable under physiological conditions, yet it possesses a high degree of latent reactivity that can be

selectively unleashed under specific conditions, making it a powerful tool for covalently linking molecules.[4]

Core Principles of Azide-Alkyne Click Chemistry

The foundation of the azide's utility in bioconjugation lies in its [3+2] cycloaddition reaction with an alkyne, which forms a stable triazole ring. This reaction is characterized by its high thermodynamic driving force, leading to a rapid and irreversible transformation.[5][6]

Copper(I)-Catalyzed Azide-Alkyne Cycloaddition (CuAAC)

The CuAAC reaction is the prototypical "click" reaction, where a copper(I) catalyst dramatically accelerates the cycloaddition between a terminal alkyne and an azide.[7][8] This reaction is highly efficient, often proceeding to near-quantitative yields in aqueous solutions and over a broad pH range (typically 4-11).[4][7] The copper(I) catalyst plays a crucial role in activating the terminal alkyne, making it susceptible to nucleophilic attack by the azide.

Strain-Promoted Azide-Alkyne Cycloaddition (SPAAC)

To circumvent the potential cytotoxicity of the copper catalyst in living systems, the strain-promoted azide-alkyne cycloaddition (SPAAC) was developed.[9] SPAAC is a catalyst-free reaction that utilizes a cyclooctyne, a highly strained cyclic alkyne. The release of ring strain provides the thermodynamic driving force for the cycloaddition with an azide.[5] This approach is particularly well-suited for in vivo applications and live-cell imaging where the presence of a metal catalyst is undesirable.[9]

Quantitative Comparison of CuAAC and SPAAC

The choice between CuAAC and SPAAC often depends on the specific application, balancing the need for rapid kinetics against the requirement for biocompatibility. The following tables provide a summary of key quantitative data to aid in this selection.

Feature	Copper(I)-Catalyzed Azide-Alkyne Cycloaddition (CuAAC)	Strain-Promoted Azide-Alkyne Cycloaddition (SPAAC)	References
Catalyst	Copper(I)	None	[7],[10]
Reaction Rate	Very fast (second-order rate constants typically 1-100 $M^{-1}s^{-1}$)	Slower than CuAAC, highly dependent on the cyclooctyne structure	[11]
Biocompatibility	Limited in vivo due to copper cytotoxicity; ligands can mitigate toxicity	Excellent; catalyst-free nature makes it ideal for in vivo and live-cell applications	[12],[9]
Reactant Scope	Terminal alkynes	Strained cyclooctynes (e.g., DBCO, BCN, DIBO)	[8],[13]
Typical Yields	High to quantitative	Generally high, but can be influenced by steric hindrance	[14]

Cyclooctyne Reagent	Second-Order Rate Constant (k_2) with Benzyl Azide ($M^{-1}s^{-1}$)	References
DIBO	~0.3 - 0.7	[13]
DBCO	~0.6 - 1.0	[13]
BCN	~0.06 - 0.1	[13]
m[9+1]CPP	9.6×10^{-3}	
[9+1]CPP	2.2×10^{-3}	
[11+1]CPP	4.5×10^{-4}	

Experimental Protocols

Detailed methodologies are crucial for the successful implementation of click chemistry in bioconjugation. The following are representative protocols for key experiments.

Protocol 1: General Procedure for Copper(I)-Catalyzed Azide-Alkyne Cycloaddition (CuAAC) of a Protein

Materials:

- Azide-modified protein in a suitable buffer (e.g., PBS, pH 7.4)
- Alkyne-containing molecule (e.g., fluorescent dye, biotin)
- Copper(II) sulfate (CuSO_4) stock solution (e.g., 100 mM in water)
- Ligand stock solution (e.g., THPTA, 200 mM in water)
- Reducing agent stock solution (e.g., sodium ascorbate, 100 mM in water, freshly prepared)
- DMSO (for dissolving hydrophobic molecules)

Procedure:

- Protein Preparation: Ensure the azide-modified protein is in a buffer free of chelating agents (e.g., EDTA) and at a suitable concentration (typically 1-10 mg/mL).
- Reagent Preparation:
 - Prepare a stock solution of the alkyne-containing molecule in DMSO or an appropriate solvent.
 - Just before use, prepare the catalyst premix by mixing the CuSO_4 and ligand stock solutions in a 1:2 molar ratio.[\[15\]](#)
- Reaction Setup:

- In a microcentrifuge tube, combine the azide-modified protein solution and the alkyne-containing molecule (typically at a 4- to 10-fold molar excess over the protein).[15]
- Add the catalyst premix to the reaction mixture. A final copper concentration of 50-200 μM is common.[16][17]
- Initiate the reaction by adding the freshly prepared sodium ascorbate solution to a final concentration of 2.5-5 mM.
- Incubation: Gently mix the reaction and incubate at room temperature for 30-60 minutes, protected from light.[15]
- Purification: Purify the conjugated protein using a suitable method such as size-exclusion chromatography (e.g., a desalting column) to remove unreacted reagents, catalyst, and ligand.[2]

Protocol 2: Live Cell Surface Labeling using Strain-Promoted Azide-Alkyne Cycloaddition (SPAAC)

Materials:

- Cells with azide groups metabolically incorporated onto their surface glycans (e.g., by incubating with Ac₄ManNAz).
- Cyclooctyne-conjugated fluorophore (e.g., DBCO-fluorophore).
- Complete cell culture medium.
- Phosphate-buffered saline (PBS).
- Fluorescence microscope or flow cytometer.

Procedure:

- Metabolic Labeling:
 - Culture cells in the presence of an azide-functionalized sugar precursor (e.g., 50 μM Ac₄ManNAz) for 48 hours to allow for metabolic incorporation into cell surface glycans.

- SPAAC Reaction:
 - Prepare a stock solution of the DBCO-fluorophore in DMSO.
 - Dilute the DBCO-fluorophore in pre-warmed complete culture medium to a final concentration of 20-50 μM .
 - Wash the azide-labeled cells twice with warm PBS.
 - Add the DBCO-fluorophore solution to the cells and incubate for 15-30 minutes at 37°C, protected from light.
- Washing and Analysis:
 - Wash the cells three times with warm PBS to remove any unreacted DBCO-fluorophore.
 - Analyze the labeled cells using fluorescence microscopy or flow cytometry.

Visualizing Click Chemistry Mechanisms and Workflows

The following diagrams, generated using the DOT language, illustrate the core mechanisms of CuAAC and SPAAC, as well as a typical workflow for the synthesis of an antibody-drug conjugate (ADC).

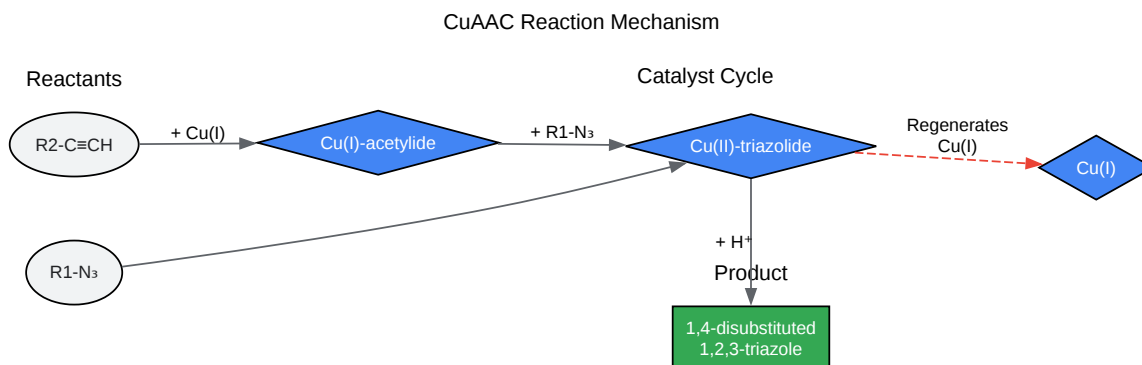

[Click to download full resolution via product page](#)

CuAAC Reaction Mechanism

SPAAC Reaction Mechanism

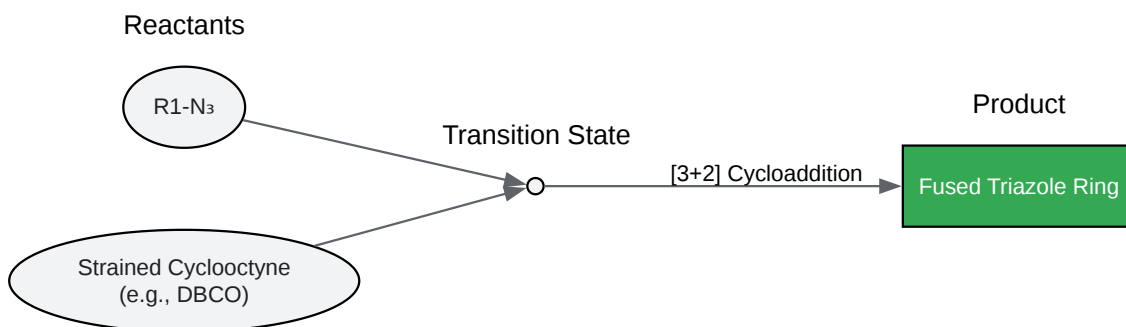

[Click to download full resolution via product page](#)

SPAAC Reaction Mechanism

Antibody-Drug Conjugate (ADC) Synthesis Workflow

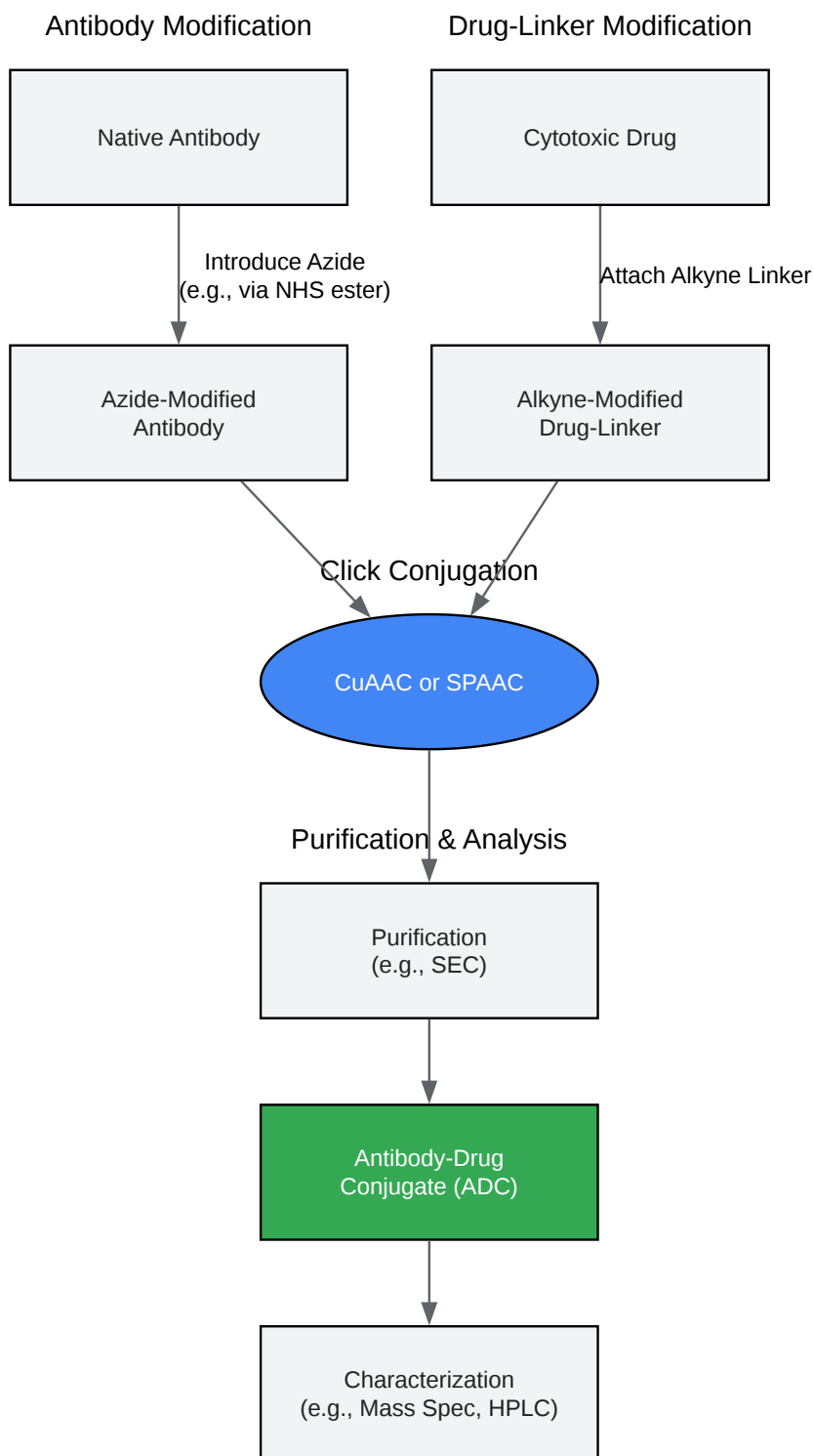

[Click to download full resolution via product page](#)

Need Custom Synthesis?

BenchChem offers custom synthesis for rare earth carbides and specific isotopic labeling.

Email: info@benchchem.com or [Request Quote Online](#).

References

- [1. researchgate.net \[researchgate.net\]](https://www.researchgate.net)
- [2. Conjugation Based on Click Chemistry - Creative Biolabs \[creative-biolabs.com\]](https://www.creative-biolabs.com)
- [3. benchchem.com \[benchchem.com\]](https://www.benchchem.com)
- [4. cdn2.sapphirebioscience.com \[cdn2.sapphirebioscience.com\]](https://cdn2.sapphirebioscience.com)
- [5. pubs.acs.org \[pubs.acs.org\]](https://pubs.acs.org)
- [6. Labeling proteins on live mammalian cells using click chemistry - PubMed \[pubmed.ncbi.nlm.nih.gov\]](https://pubmed.ncbi.nlm.nih.gov)
- [7. Experimental and theoretical elucidation of SPAAC kinetics for strained alkyne-containing cycloparaphenylenes - PMC \[pmc.ncbi.nlm.nih.gov\]](https://pubmed.ncbi.nlm.nih.gov)
- [8. benchchem.com \[benchchem.com\]](https://www.benchchem.com)
- [9. benchchem.com \[benchchem.com\]](https://www.benchchem.com)
- [10. benchchem.com \[benchchem.com\]](https://www.benchchem.com)
- [11. Peptide Conjugation via CuAAC 'Click' Chemistry \[mdpi.com\]](https://www.mdpi.com)
- [12. Alkyne Azide Click Chemistry Protocol for ADC Bioconjugation with Real Examples | AxisPharm \[axispharm.com\]](https://www.axispharm.com)
- [13. Click Chemistry \(CuAAC\) and Detection of Tagged de novo Synthesized Proteins in Drosophila - PMC \[pmc.ncbi.nlm.nih.gov\]](https://pubmed.ncbi.nlm.nih.gov)
- [14. Click Chemistry \(CuAAC\) and Detection of Tagged de novo Synthesized Proteins in Drosophila \[bio-protocol.org\]](https://www.bio-protocol.org)
- [15. researchgate.net \[researchgate.net\]](https://www.researchgate.net)
- [16. Labeling Live Cells by Copper-Catalyzed Alkyne-Azide Click Chemistry - PMC \[pmc.ncbi.nlm.nih.gov\]](https://pubmed.ncbi.nlm.nih.gov)
- [17. benchchem.com \[benchchem.com\]](https://www.benchchem.com)

- To cite this document: BenchChem. [The Azide Group: A Locus of Reactivity in Click Chemistry for Bioconjugation]. BenchChem, [2026]. [Online PDF]. Available at: [<https://www.benchchem.com/product/b15565451/docs#the-azide-group-a-locus-of-reactivity-in-click-chemistry-for-bioconjugation>]

Disclaimer & Data Validity:

The information provided in this document is for Research Use Only (RUO) and is strictly not intended for diagnostic or therapeutic procedures. While BenchChem strives to provide accurate protocols, we make no warranties, express or implied, regarding the fitness of this product for every specific experimental setup.

Technical Support: The protocols provided are for reference purposes. Unsure if this reagent suits your experiment?

Need Industrial/Bulk Grade? [Request Custom Synthesis Quote](#)

BenchChem

Our mission is to be the trusted global source of essential and advanced chemicals, empowering scientists and researchers to drive progress in science and industry.

Contact

Address: 3281 E Guasti Rd
Ontario, CA 91761, United States
Phone: (601) 213-4426
Email: info@benchchem.com

[Contact our Ph.D. Support Team for a compatibility check](#)