

# Technical Support Center: Troubleshooting HIV-1 Reverse Transcriptase (RT) Assays

**Author:** BenchChem Technical Support Team. **Date:** April 2026

## Compound of Interest

Compound Name: 12-Oxocalanolide A  
CAS No.: 151005-67-3; 161753-49-7  
Cat. No.: B15565643

[Get Quote](#)

Welcome to the technical support center for HIV-1 Reverse Transcriptase (RT) assays. This resource is designed for researchers, scientists, and drug development professionals to help troubleshoot and resolve common issues encountered during experimentation, ensuring the generation of accurate and reproducible data.

## Frequently Asked Questions (FAQs)

Q1: What are the common types of HIV-1 RT assays?

A1: HIV-1 RT activity is typically measured using one of three main assay formats:

- **Colorimetric Assays:** These assays, often in an ELISA format, measure the incorporation of labeled nucleotides (e.g., digoxigenin-labeled dUTP) into a DNA strand. The amount of incorporated label is then detected with an antibody conjugate that produces a colorimetric signal.
- **Fluorescent Assays:** Similar to colorimetric assays, these methods use fluorescently labeled nucleotides or a fluorescent dye that intercalates with the newly synthesized double-stranded DNA. The resulting fluorescence is proportional to the RT activity.

- Real-Time PCR (qPCR)-based Assays: Also known as Product-Enhanced Reverse Transcriptase (PERT) assays, these are highly sensitive methods that quantify the cDNA product of the RT reaction using real-time PCR. SYBR Green or probe-based (e.g., TaqMan) detection is used to measure the amplification of the cDNA in real-time.[1]

Q2: What are the critical reagents in an HIV-1 RT assay?

A2: The core components of an HIV-1 RT assay include the HIV-1 RT enzyme (or sample containing the enzyme), a template (typically RNA), a primer, deoxynucleotide triphosphates (dNTPs), and a reaction buffer containing divalent cations (e.g.,  $Mg^{2+}$  or  $Mn^{2+}$ ) as cofactors for the enzyme.[2]

Q3: How should I store the HIV-1 RT enzyme and other kit components?

A3: Proper storage is crucial for maintaining reagent stability. Generally, the HIV-1 RT enzyme and reaction buffers should be stored at  $-20^{\circ}C$ . The enzyme is often supplied in a glycerol-containing buffer to prevent freeze-thaw damage.[2] It is recommended to aliquot reagents into smaller volumes to avoid repeated freeze-thaw cycles. Always refer to the manufacturer's instructions for specific storage conditions.

Q4: What is the cause of the high genetic variability of HIV-1, and how does it affect RT assays?

A4: The high genetic variability of HIV-1 is primarily due to the error-prone nature of the reverse transcriptase enzyme, which lacks a proofreading mechanism.[3] This results in a high mutation rate. For RT assays, this variability can be a challenge, especially for qPCR-based methods that rely on specific primer and probe binding. It is important to use primers and probes that target highly conserved regions of the RT gene to ensure broad detection of different HIV-1 subtypes.

## Troubleshooting Guides

This section provides solutions to common problems you may encounter during your HIV-1 RT assays.

### Issue 1: High Background Signal

Q: My negative controls show a high signal. What could be the cause?

A: High background in negative controls can be due to several factors:

- Contamination: The most common cause is contamination of reagents or samples with HIV-1 RT or previously amplified DNA.
  - Solution: Use dedicated pipettes and filter tips. Physically separate pre-PCR and post-PCR work areas. Regularly decontaminate work surfaces and equipment.
- Non-specific Amplification (qPCR-based assays): In SYBR Green assays, primer-dimers or non-specific amplification can lead to a high background signal.[4]
  - Solution: Optimize primer concentrations and the annealing temperature.[5] Perform a melt curve analysis to check for the presence of a single, specific product.[4]
- Insufficient Washing (ELISA-based assays): Inadequate washing can leave behind unbound detection antibodies, resulting in a high background.
  - Solution: Ensure that the washing steps are performed thoroughly and that all wells are completely emptied between washes.[1]
- Cross-reactivity of Antibodies: In some cases, the detection antibodies may cross-react with other components in the sample.
  - Solution: If possible, try a different antibody or blocking reagent.

## Issue 2: Low or No Signal

Q: I am not getting any signal, or the signal is very low, even in my positive controls. What should I do?

A: A low or absent signal can indicate a problem with one or more components of the assay:

- Inactive Enzyme: The HIV-1 RT enzyme may have lost its activity due to improper storage or handling.

- Solution: Ensure the enzyme has been stored at the correct temperature and has not undergone excessive freeze-thaw cycles. Use a fresh aliquot of the enzyme.
- Suboptimal Reaction Conditions: The reaction buffer composition, dNTP concentration, or incubation temperature/time may not be optimal.
  - Solution: Optimize the concentration of  $Mg^{2+}$ , dNTPs, and primers.[6] Ensure the incubation is carried out at the recommended temperature and for the appropriate duration.[7]
- Degraded RNA Template: The RNA template may have been degraded by RNases.
  - Solution: Use RNase-free water, reagents, and plasticware. Include an RNase inhibitor in the reaction.
- Presence of Inhibitors: Samples may contain inhibitors of reverse transcriptase activity.[8]
  - Solution: Dilute the sample to reduce the concentration of inhibitors. Some sample preparation methods can help remove inhibitors.
- Pipetting Errors: Inaccurate pipetting, especially of small volumes, can lead to incorrect reagent concentrations.[9]
  - Solution: Use calibrated pipettes and proper pipetting techniques, such as pre-wetting the tip and reverse pipetting for viscous solutions.[9][10]

### Issue 3: High Variability in Results

Q: I am observing high variability between replicate wells (intra-assay variability) and between different plates (inter-assay variability). How can I improve the precision of my assay?

A: High variability can compromise the reliability of your results. Here are some common causes and solutions:

- Inconsistent Pipetting: This is a major source of variability in microplate-based assays.[9]
  - Solution: Ensure consistent pipetting technique across all wells and plates.[10] Use a multichannel pipette for adding reagents to multiple wells simultaneously, and ensure all

channels are dispensing equal volumes.

- Poor Mixing: Inadequate mixing of reagents in the wells can lead to inconsistent results.
  - Solution: Mix the contents of the wells thoroughly by gently pipetting up and down or by using a plate shaker.[9]
- "Edge Effect" in Microplates: Wells on the edge of the plate may show different results due to temperature gradients or increased evaporation.
  - Solution: Avoid using the outer wells of the plate. Fill the outer wells with buffer or water to create a more uniform temperature distribution across the plate.
- Plate-to-Plate Inconsistency (ELISA-based assays): Variations in the surface properties of microplates can affect protein coating and lead to inter-assay variability.[1][11]
  - Solution: Use plates from the same manufacturer and lot number for an entire experiment.
- Instrument Variability: Issues with the plate reader, such as a failing light source, can introduce variability.[12]
  - Solution: Regularly maintain and calibrate your plate reader.

## Issue 4: False Positive Results

Q: Is it possible to get a false positive result in an HIV-1 RT assay?

A: While less common in enzymatic assays compared to antibody-based diagnostic tests, false positives can occur.

- Contamination: As mentioned earlier, contamination with HIV-1 RT or DNA from previous experiments is a primary cause of false positives.
  - Solution: Strict adherence to good laboratory practices for preventing contamination is essential.
- Cross-Reactivity (in biological samples): Some biological samples may contain substances that can cause a false positive signal. For instance, certain autoimmune diseases or recent

vaccinations can lead to the production of cross-reacting antibodies that might interfere with some assay formats.[13][14] While this is more relevant to HIV diagnostic tests, it's a possibility to consider.

- Solution: If a false positive is suspected, re-testing a new sample and using an alternative assay method for confirmation is recommended.

## Quantitative Data Summary

Parameter	Recommended Range/Value	Notes
Primer Concentration (qPCR)	300 - 800 nM	Optimal concentration should be determined experimentally. [5]
Probe Concentration (TaqMan qPCR)	100 - 250 nM	A primer-to-probe ratio of 2:1 is often a good starting point.[7]
dNTP Concentration	0.1 - 0.2 mM	Higher concentrations can sometimes be inhibitory.
Incubation Temperature	37°C - 50°C	The optimal temperature can depend on the specific HIV-1 RT variant and the assay system.[15]
Incubation Time	20 minutes - 24 hours	Shorter times are used for screening, while longer times increase sensitivity for detecting low levels of RT.
qPCR Annealing Temperature	55°C - 65°C	Best determined experimentally using a temperature gradient.[4]

## Experimental Protocols

### Protocol 1: Colorimetric ELISA-based HIV-1 RT Assay

This protocol is a generalized procedure based on commercially available kits.

- **Reagent Preparation:** Thaw all reagents and keep them on ice. Prepare the 1x reaction buffer by mixing equal volumes of reaction buffer 1 and reaction buffer 2.
- **Reaction Setup:** In incubation tubes, add 40  $\mu\text{L}$  of the reaction buffer (or reaction buffer containing the test compound).
- **Enzyme Addition:** Add 80  $\mu\text{L}$  of the HIV-1 RT standard or sample diluted in lysis buffer to the respective tubes.
- **Incubation:** Incubate the mixture at 37°C for 20 minutes to 24 hours, depending on the desired sensitivity.
- **Capture:** Transfer 100  $\mu\text{L}$  of the reaction mixture to a streptavidin-coated microplate well.
- **Incubation and Washing:** Incubate the plate at 37°C for 20 minutes. Wash the wells 5 times with 1x wash buffer.
- **Detection:** Add 100  $\mu\text{L}$  of HRP-conjugated anti-digoxigenin antibody and incubate at 37°C for 45 minutes. Wash the wells 5 times with 1x wash buffer.
- **Substrate Addition:** Add 100  $\mu\text{L}$  of ABTS substrate and incubate at room temperature in the dark for 30 minutes.
- **Stop Reaction:** Add 100  $\mu\text{L}$  of stop solution.
- **Read Plate:** Measure the absorbance at 405 nm using a microplate reader.

## Protocol 2: SYBR Green-based qPCR (PERT) Assay

This protocol is adapted from the SG-PERT assay methodology.<sup>[16]</sup>

- **Sample Lysis:** Mix 5  $\mu\text{L}$  of the viral supernatant or RT standard with 5  $\mu\text{L}$  of 2x lysis buffer containing an RNase inhibitor. Incubate at room temperature for 10 minutes. Dilute the lysate with 90  $\mu\text{L}$  of nuclease-free water.
- **Reaction Mix Preparation:** Prepare a master mix containing SYBR Green qPCR master mix, MS2 RNA template, and MS2 forward and reverse primers.

- qPCR Setup: In a qPCR plate, add the appropriate volume of the master mix and 9  $\mu$ L of the diluted lysate to each well.
- qPCR Run: Perform the one-step RT-qPCR with the following cycling conditions:
  - Reverse Transcription: 50°C for 30 minutes
  - Initial Denaturation: 95°C for 10 minutes
  - 40 Cycles of:
    - Denaturation: 95°C for 15 seconds
    - Annealing/Extension: 60°C for 60 seconds
- Melt Curve Analysis: Perform a melt curve analysis to verify the specificity of the amplified product.
- Data Analysis: Determine the Ct values and quantify the RT activity based on a standard curve generated from a dilution series of a known RT standard.

## Visualizations

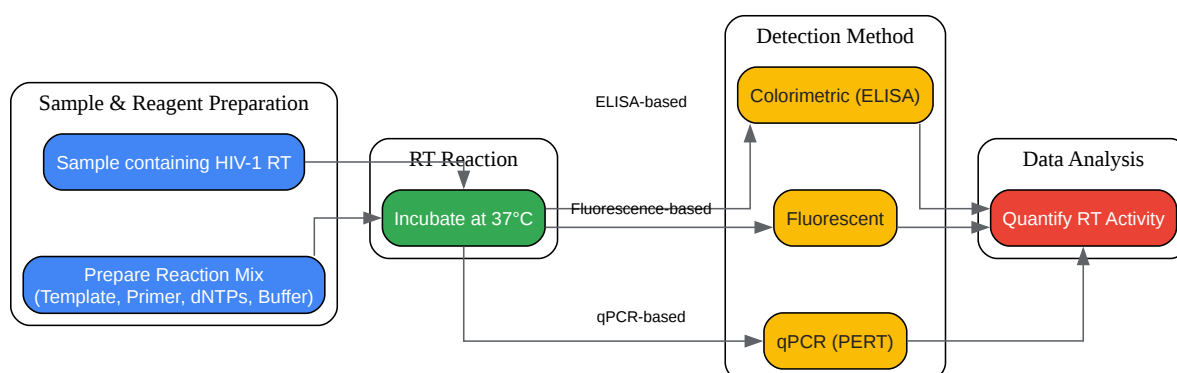

[Click to download full resolution via product page](#)

Caption: General workflow for HIV-1 RT assays.

Caption: Troubleshooting decision tree for HIV-1 RT assays.

### **Need Custom Synthesis?**

*BenchChem offers custom synthesis for rare earth carbides and specific isotopic labeling.*

*Email: [info@benchchem.com](mailto:info@benchchem.com) or [Request Quote Online](#).*

## References

- [1. researchgate.net \[researchgate.net\]](#)
- [2. Reverse Transcriptase, Recombinant HIV - Worthington Enzyme Manual | Worthington Biochemical \[worthington-biochem.com\]](#)
- [3. A Guide to HIV-1 Reverse Transcriptase and Protease Sequencing for Drug Resistance Studies - PMC \[pmc.ncbi.nlm.nih.gov\]](#)
- [4. benchchem.com \[benchchem.com\]](#)
- [5. Optimize qPCR Using SYBR Green Assays - Ask TaqMan #38 - Behind the Bench \[thermofisher.com\]](#)
- [6. Quantitative Evaluation of Very Low Levels of HIV-1 Reverse Transcriptase by a Novel Highly Sensitive RT-qPCR Assay - PMC \[pmc.ncbi.nlm.nih.gov\]](#)
- [7. mdpi.com \[mdpi.com\]](#)
- [8. Inhibitors of HIV-1 Reverse Transcriptase—Associated Ribonuclease H Activity - PMC \[pmc.ncbi.nlm.nih.gov\]](#)
- [9. nanotempertech.com \[nanotempertech.com\]](#)
- [10. americanlaboratory.com \[americanlaboratory.com\]](#)
- [11. Variability in Microplate Surface Properties and Its Impact on ELISA - PubMed \[pubmed.ncbi.nlm.nih.gov\]](#)
- [12. cygnustechnologies.com \[cygnustechnologies.com\]](#)
- [13. primeinfusions.com \[primeinfusions.com\]](#)
- [14. False positive HIV results: Causes, risks, and best practices \[medicalnewstoday.com\]](#)

- [15. HIV-1 RTase \(HIV-1 Reverse Transcriptase\) - HIV-1 RTase \(HIV-1 Reverse Transcriptase\) \[croyezbio.com\]](#)
- [16. Natural Products with Inhibitory Activity against Human Immunodeficiency Virus Type 1 - PMC \[pmc.ncbi.nlm.nih.gov\]](#)
- To cite this document: BenchChem. [Technical Support Center: Troubleshooting HIV-1 Reverse Transcriptase (RT) Assays]. BenchChem, [2026]. [Online PDF]. Available at: [<https://www.benchchem.com/product/b15565643/docs#technical-support-center-troubleshooting-hiv-1-reverse-transcriptase-rt-assays>]

---

### Disclaimer & Data Validity:

The information provided in this document is for Research Use Only (RUO) and is strictly not intended for diagnostic or therapeutic procedures. While BenchChem strives to provide accurate protocols, we make no warranties, express or implied, regarding the fitness of this product for every specific experimental setup.

**Technical Support:** The protocols provided are for reference purposes. Unsure if this reagent suits your experiment?

**Need Industrial/Bulk Grade?** [Request Custom Synthesis Quote](#)

## BenchChem

Our mission is to be the trusted global source of essential and advanced chemicals, empowering scientists and researchers to drive progress in science and industry.

### Contact

Address: 3281 E Guasti Rd  
Ontario, CA 91761, United States  
Phone: (601) 213-4426  
Email: [info@benchchem.com](mailto:info@benchchem.com)

[Contact our Ph.D. Support Team for a compatibility check](#)

